

VHF/UHF WIDE BAND AMPLIFIER APPLICATION.

### FEATURES

- Low Noise Figure, High Gain.
- NF=1.1dB,  $|S_{21e}|^2=11\text{dB}$  (f=1GHz).

### MAXIMUM RATING (Ta=25°C)

CHARACTERISTIC	SYMBOL	RATING	UNIT
Collector-Base Voltage	$V_{CBO}$	20	V
Collector-Emitter Voltage	$V_{CEO}$	12	V
Emitter-Base Voltage	$V_{EBO}$	3	V
Collector Current	$I_C$	100	mA
Collector Power Dissipation	$P_C$	150	mW
Junction Temperature	$T_j$	150	°C
Storage Temperature Range	$T_{stg}$	-55 ~ 150	°C

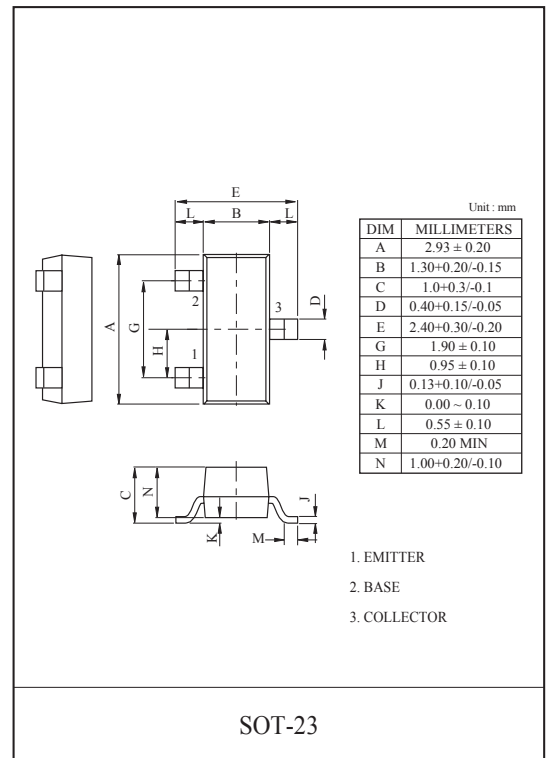

### Marking

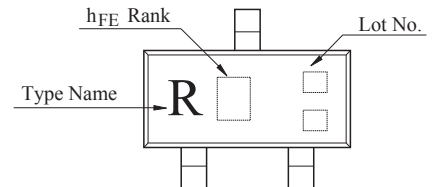

### ELECTRICAL CHARACTERISTICS (Ta=25°C)

CHARACTERISTIC	SYMBOL	TEST CONDITION	MIN.	TYP.	MAX.	UNIT
Collector Cut-off Current	$I_{CBO}$	$V_{CB}=10\text{V}, I_E=0$	-	-	1	$\mu\text{A}$
Emitter Cut-off Current	$I_{EBO}$	$V_{EB}=1\text{V}, I_C=0$	-	-	1	$\mu\text{A}$
DC Current Gain	$h_{FE}$ (Note1)	$V_{CE}=10\text{V}, I_C=20\text{mA}$	50	-	250	
Collector Output Capacitance	$C_{ob}$	$V_{CB}=10\text{V}, I_E=0, f=1\text{MHz}$ (Note2)	-	-	1.0	pF
Reverse Transfer Capacitance	$C_{re}$		-	0.65	1.15	pF
Transition Frequency	$f_T$	$V_{CE}=10\text{V}, I_C=20\text{mA}$	5	7	-	GHz
Insertion Gain	$ S_{21e} ^2$	$V_{CE}=10\text{V}, I_C=20\text{mA}, f=1\text{GHz}$	7.5	11.5	-	dB
Noise Figure	NF	$V_{CE}=10\text{V}, I_C=7\text{mA}, f=1\text{GHz}$	-	1.1	2	dB

Note 1 :  $h_{FE}$  Classification A:50~100, B:80~160, C:125~250.

Note 2 :  $C_{re}$  is measured by 3 terminal method with capacitance bridge.

# KTC3770S

## TYPICAL CHARACTERISTICS (Ta=25°C)

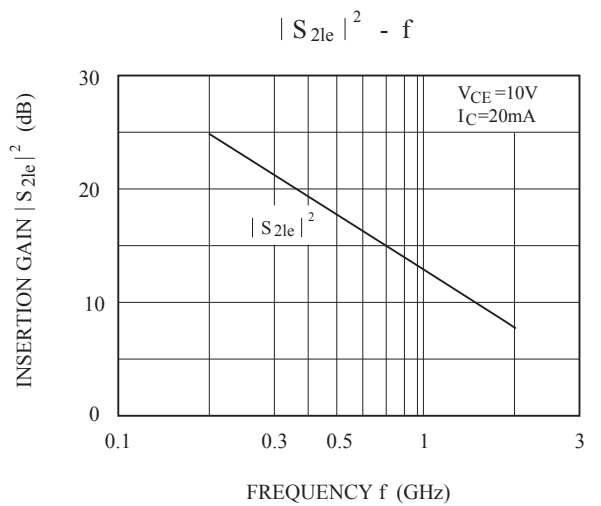
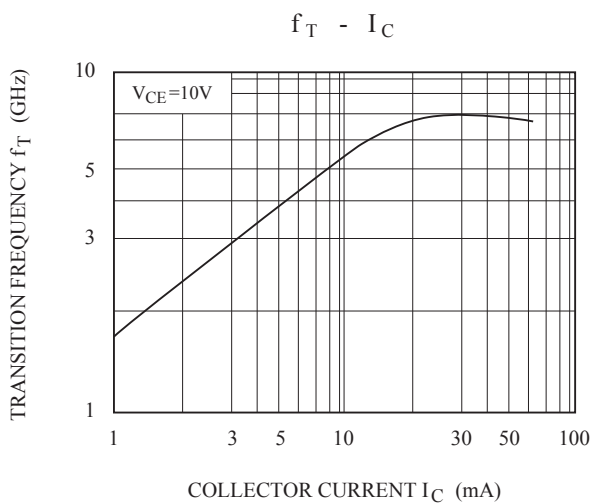
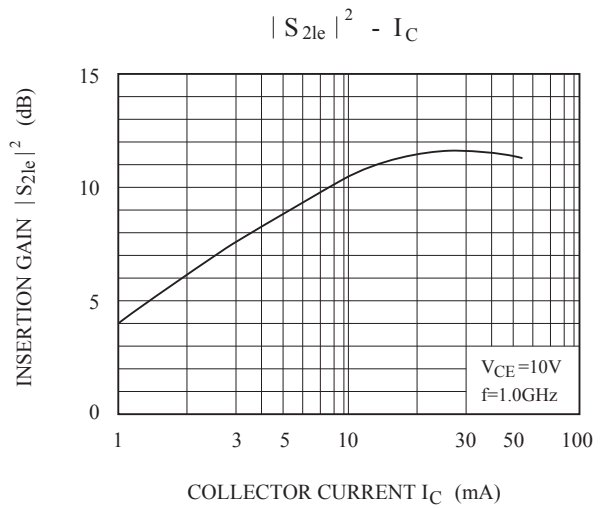
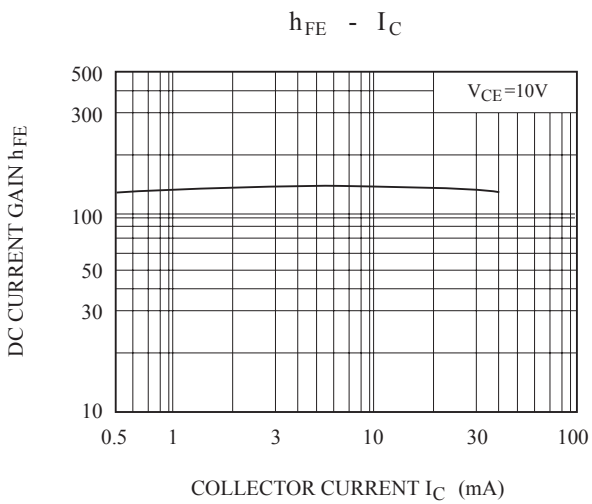
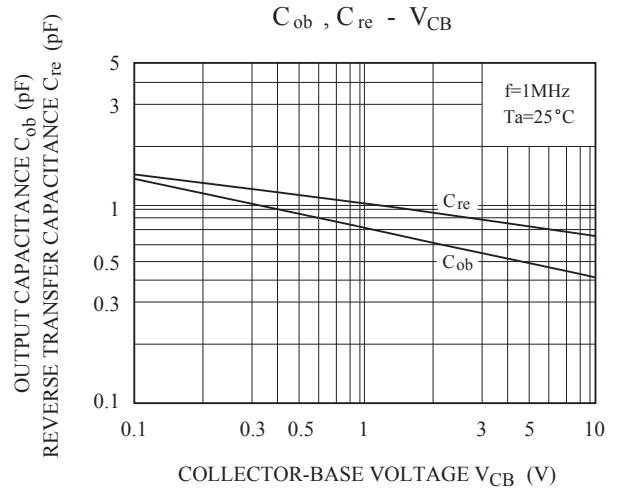
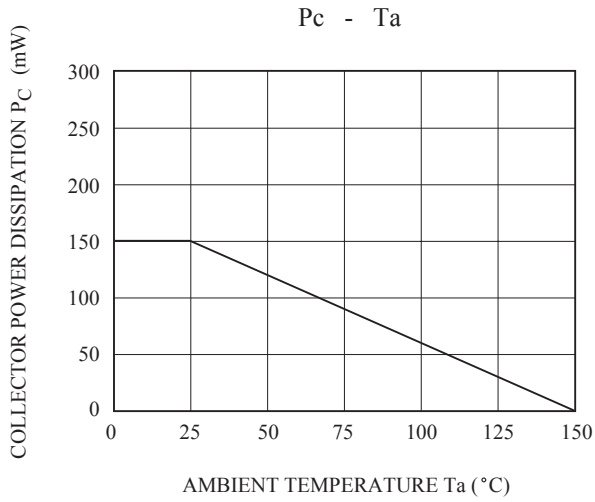

# KTC3770S

NF -  $I_C$

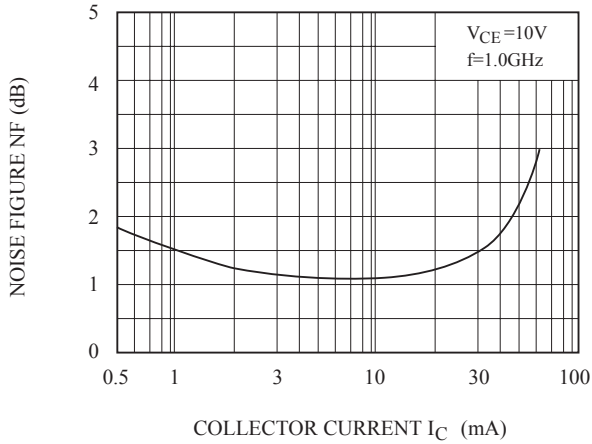

$|S_{21e}|^2 - V_{CE}$

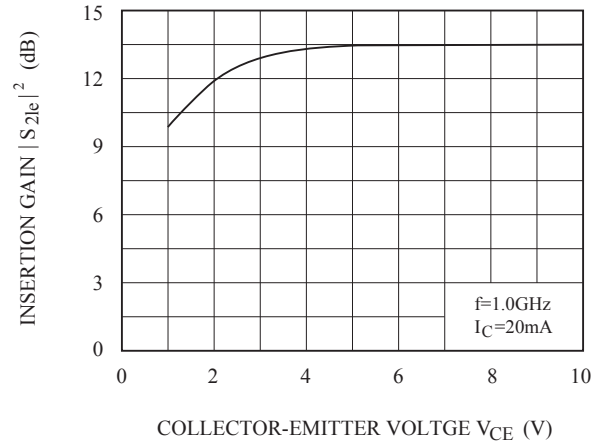

## S-PARAMETER

( $V_{CE}=10V$ ,  $I_C=5mA$ ,  $Z_0=50\Omega$ )

f (MHz)	$ S_{11} $	$\angle S_{11}$	$ S_{21} $	$\angle S_{21}$	$ S_{12} $	$\angle S_{12}$	$ S_{22} $	$\angle S_{22}$
200	0.651	-69.3	10.616	129.3	0.051	59.2	0.735	-28.1
400	0.467	-113.3	6.856	104.4	0.071	54.4	0.550	-34.1
600	0.391	-139.3	4.852	90.9	0.086	56.0	0.468	-33.9
800	0.360	-159.2	3.802	81.2	0.101	59.1	0.426	-33.6
1000	0.360	-176.9	3.098	72.9	0.118	61.0	0.397	-35.7
1200	0.361	172.7	2.646	67.3	0.137	63.5	0.373	-38.3
1400	0.381	160.3	2.298	59.3	0.157	63.3	0.360	-43.0
1600	0.398	152.2	2.071	55.2	0.180	64.1	0.337	-45.9
1800	0.423	143.3	1.836	49.0	0.203	63.7	0.320	-52.3
2000	0.445	137.6	1.689	46.2	0.220	64.7	0.302	-52.2

( $V_{CE}=10V$ ,  $I_C=20mA$ ,  $Z_0=50\Omega$ )

f (MHz)	$ S_{11} $	$\angle S_{11}$	$ S_{21} $	$\angle S_{21}$	$ S_{12} $	$\angle S_{12}$	$ S_{22} $	$\angle S_{22}$
200	0.339	-107.0	16.516	108.7	0.035	66.1	0.459	-36.6
400	0.258	-147.3	8.928	92.1	0.060	71.0	0.343	-32.9
600	0.243	-167.7	6.022	83.0	0.085	71.9	0.305	-29.9
800	0.242	177.0	4.633	76.2	0.109	72.2	0.284	-29.4
1000	0.260	164.5	3.744	69.9	0.136	70.4	0.266	-31.7
1200	0.269	157.6	3.193	65.7	0.160	69.9	0.246	-35.0
1400	0.294	148.7	2.750	58.8	0.187	66.7	0.233	-40.4
1600	0.314	143.1	2.479	55.5	0.212	65.2	0.208	-43.6
1800	0.343	136.5	2.185	50.1	0.238	62.4	0.190	-50.5
2000	0.367	131.4	2.016	47.8	0.254	61.6	0.173	-48.3

# KTC3770S

S<sub>11e</sub>  
 V<sub>CE</sub>=10V  
 I<sub>C</sub>=5mA  
 T<sub>a</sub>=25°C  
 (UNIT : Ω)

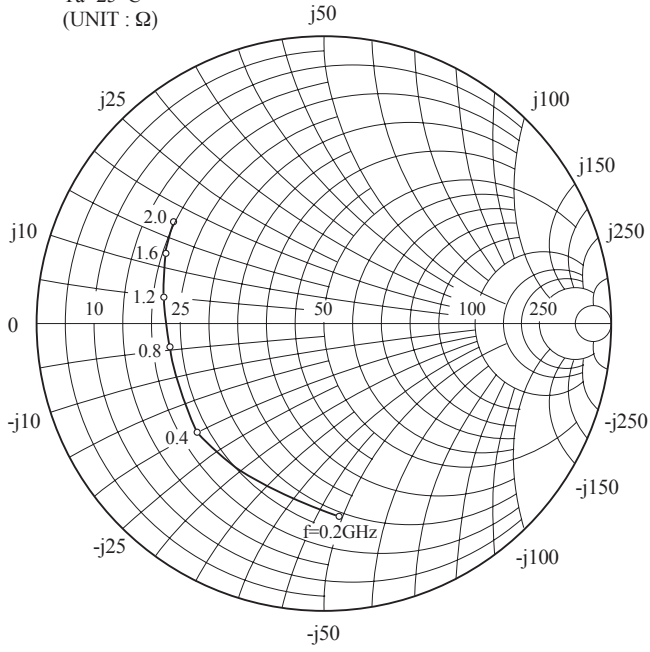

S<sub>12e</sub>  
 V<sub>CE</sub>=10V  
 I<sub>C</sub>=5mA  
 T<sub>a</sub>=25°C

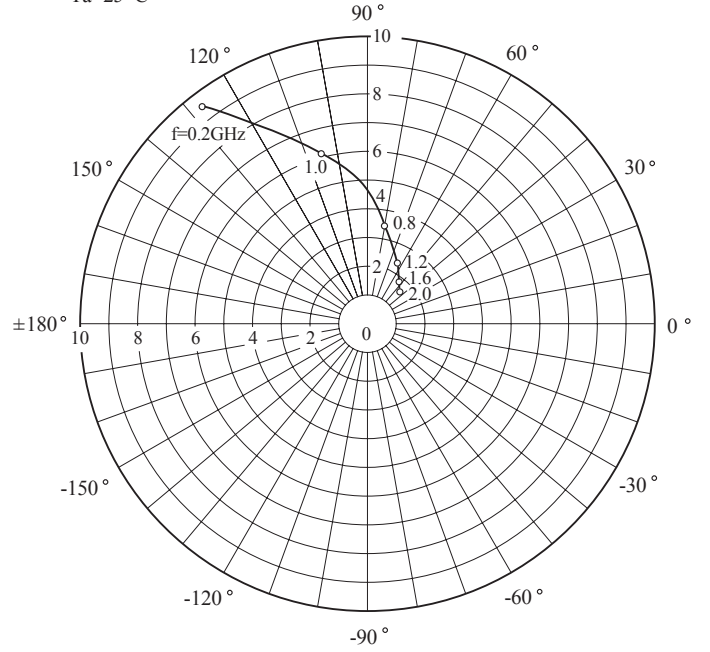

S<sub>21e</sub>  
 V<sub>CE</sub>=10V  
 I<sub>C</sub>=5mA  
 T<sub>a</sub>=25°C

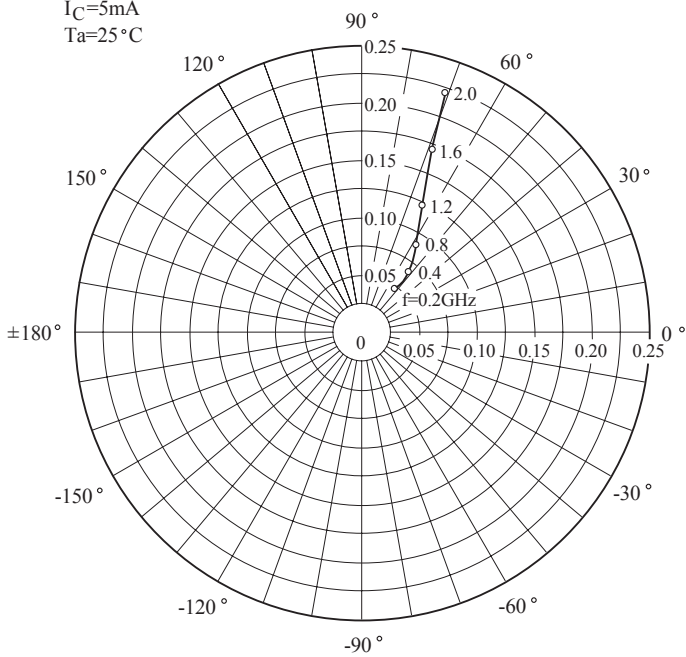

S<sub>22e</sub>  
 V<sub>CE</sub>=10V  
 I<sub>C</sub>=5mA  
 T<sub>a</sub>=25°C  
 (UNIT : Ω)

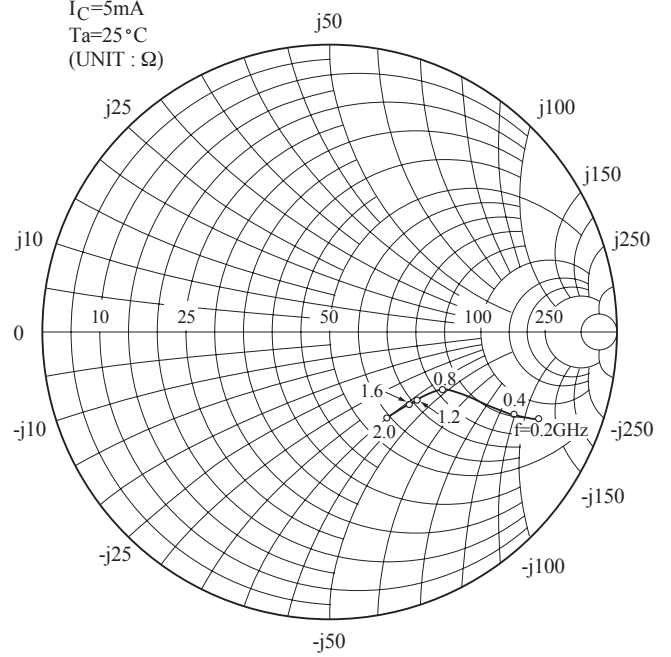

# KTC3770S

S<sub>11e</sub>  
V<sub>CE</sub>=10V  
I<sub>C</sub>=20mA  
T<sub>a</sub>=25°C  
(UNIT : Ω)

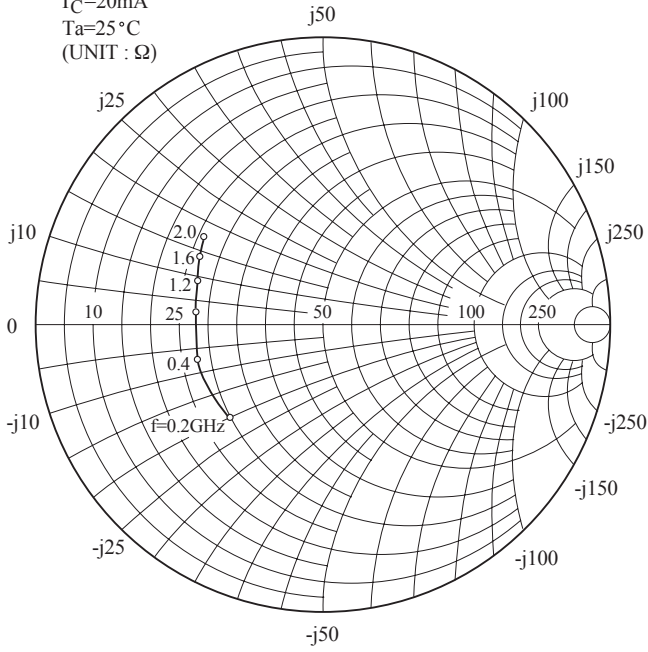

S<sub>12e</sub>  
V<sub>CE</sub>=10V  
I<sub>C</sub>=20mA  
T<sub>a</sub>=25°C

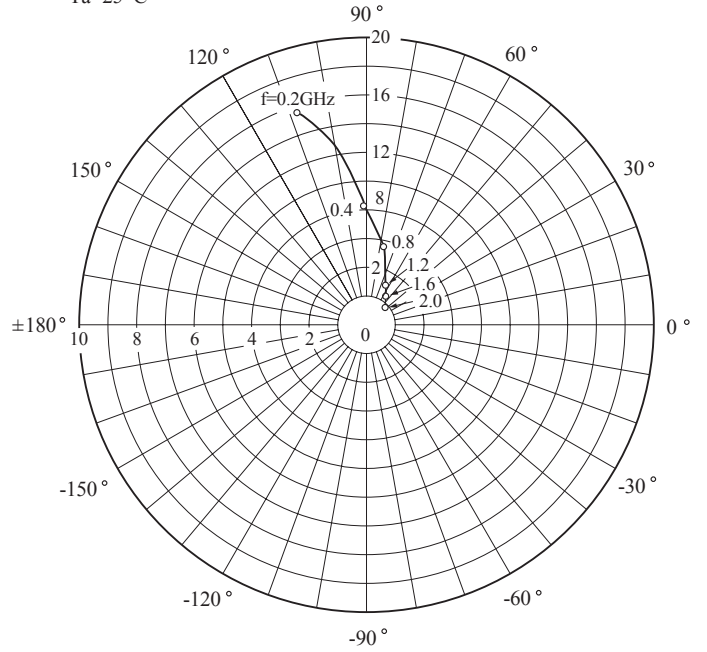

S<sub>21e</sub>  
V<sub>CE</sub>=10V  
I<sub>C</sub>=20mA  
T<sub>a</sub>=25°C

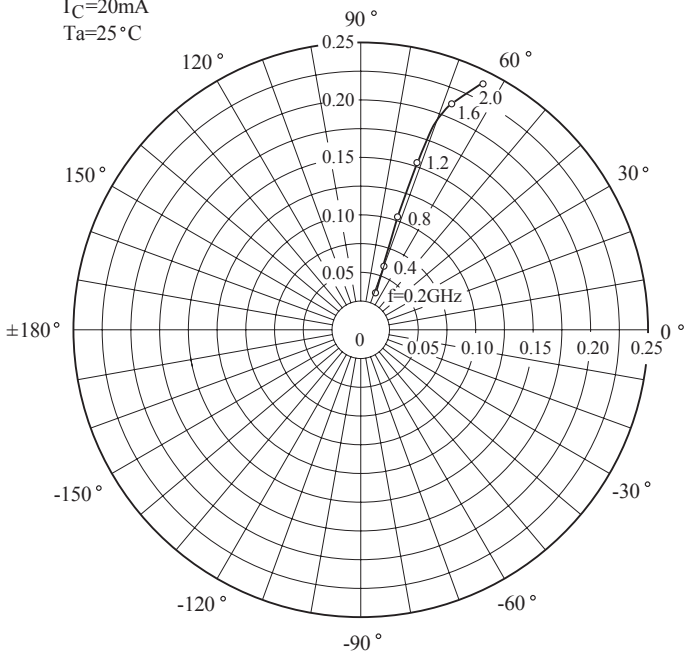

S<sub>22e</sub>  
V<sub>CE</sub>=10V  
I<sub>C</sub>=20mA  
T<sub>a</sub>=25°C  
(UNIT : Ω)

