

INTERFACE AND SWITCHING APPLICATION.

FEATURES

- ESD Protected 2000V.(Human Body Model)
- High density cell design for low $R_{DS(ON)}$.
- Voltage controlled small signal switch.
- High-speed line driver.
- Low-side loadswitch.
- Suffix U : Qualified to AEC-Q101.
ex) 2N7002KE-RTK/HU

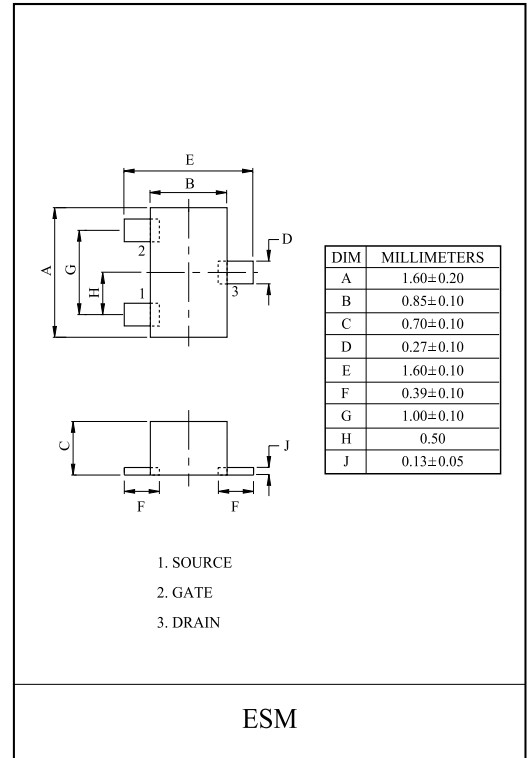

MAXIMUM RATING (Ta=25 °C)

| CHARACTERISTIC | | SYMBOL | RATING | UNIT |
|--|-----------------|------------|---------|------|
| Drain-Source Voltage | | V_{DSS} | 60 | V |
| Gate-Source Voltage | | V_{GSS} | ± 20 | V |
| Drain Current | Continuous | I_D | 300 | mA |
| | Pulsed (Note 1) | I_{DP} | 1000 | |
| Drain Power Dissipation (Note 2) | | P_D | 300 | mW |
| Junction Temperature | | T_j | 150 | |
| Storage Temperature Range | | T_{stg} | -55 150 | |
| Thermal Resistance, Junction to Ambient (Note 2) | | R_{thJA} | 416 | /W |

Note 1) Pulse Width 10µs, Duty Cycle 1%

Note 2) Surface Mounted on 2 × 2 FR4 Board

EQUIVALENT CIRCUIT

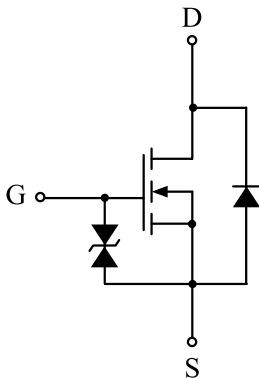

Marking

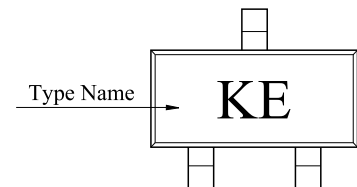

2N7002KE

ELECTRICAL CHARACTERISTICS (Ta=25)

| CHARACTERISTIC | SYMBOL | TEST CONDITION | MIN. | TYP. | MAX. | UNIT. | |
|------------------------------------|---------------|-----------------------------------|--|------|------|---------|----|
| Static | | | | | | | |
| Drain-Source Breakdown Voltage | BV_{DSS} | $V_{GS}=0V, I_D=10 \mu A$ | 60 | - | - | V | |
| Zero Gate Voltage Drain Current | I_{DSS} | $V_{DS}=60V, V_{GS}=0V$ | - | - | 1 | μA | |
| Gate-Body Leakage, Forward | I_{GSSF} | $V_{GS}=20V, V_{DS}=0V$ | - | - | 10 | μA | |
| Gate-Body Leakage, Reverse | I_{GSSR} | $V_{GS}=-20V, V_{DS}=0V$ | - | - | -10 | μA | |
| Gate Threshold Voltage | V_{th} | $V_{DS}=V_{GS}, I_D=250 \mu A$ | 1.0 | - | 2.0 | V | |
| Drain-Source ON Resistance | $R_{DS(ON)}$ | $V_{GS}=10V, I_D=300mA$ (Note 3) | - | 1.2 | 1.5 | | |
| | | $V_{GS}=4.5V, I_D=250mA$ (Note 3) | - | 1.45 | 1.9 | | |
| Forward Transconductance | g_{FS} | $V_{DS}=10V, I_D=300mA$ | 250 | - | - | mS | |
| Drain-Source Diode Forward Voltage | V_{SD} | $V_{GS}=0V, I_S=300mA$ | - | 1.0 | 1.2 | V | |
| Dynamic (Note 3) | | | | | | | |
| Input Capacitance | C_{iss} | $V_{DS}=25V, V_{GS}=0V, f=1MHz$ | - | 20 | - | pF | |
| Reverse Transfer Capacitance | C_{rss} | | - | 4 | - | | |
| Output Capacitance | C_{oss} | | - | 8 | - | | |
| Switching Time | Turn-On Time | t_{on} | $V_{DD}=30V, I_D=300mA, V_{GS}=10V$ (Note 3) | - | 9 | - | ns |
| | Turn-Off Time | t_{off} | | - | 43 | - | |

Note 3) Pulse Test : Pulse Width 80 μs , Duty Cycle 1%

SWITCHING TIME TEST CIRCUIT

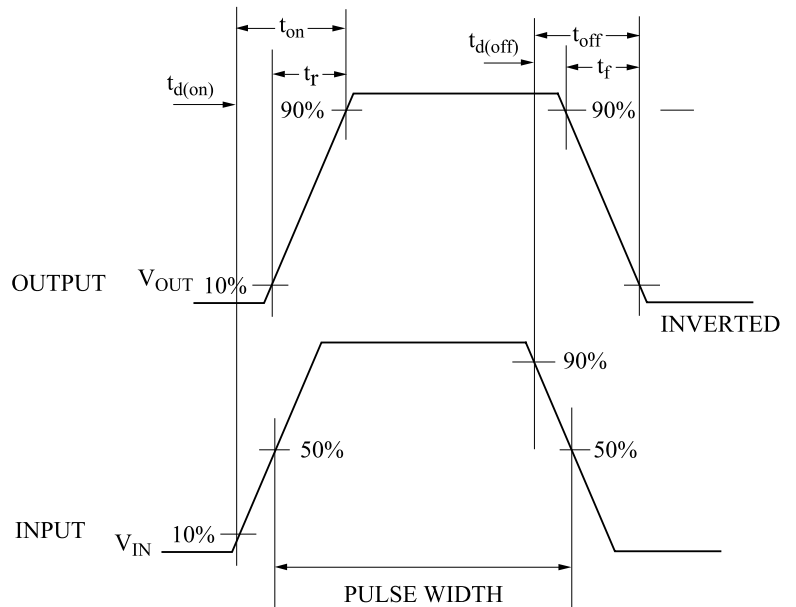
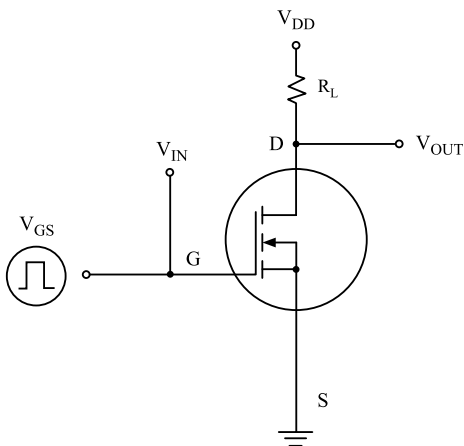

2N7002KE

Fig 1. $I_D - V_{DS}$

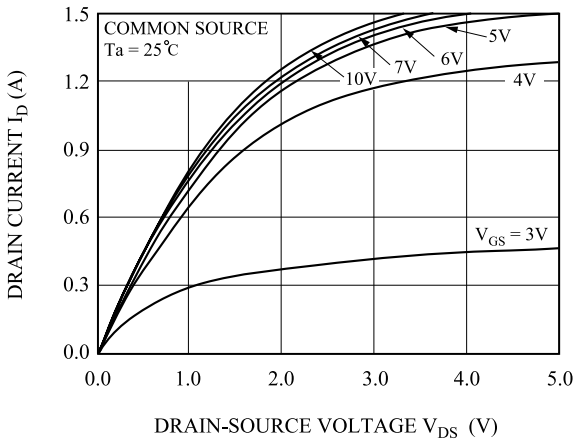

Fig 2. $R_{DS(ON)} - I_D$

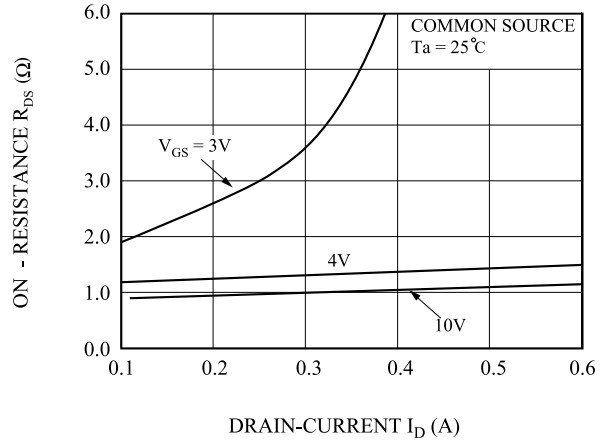

Fig 3. $R_{DS(ON)} - T_j$

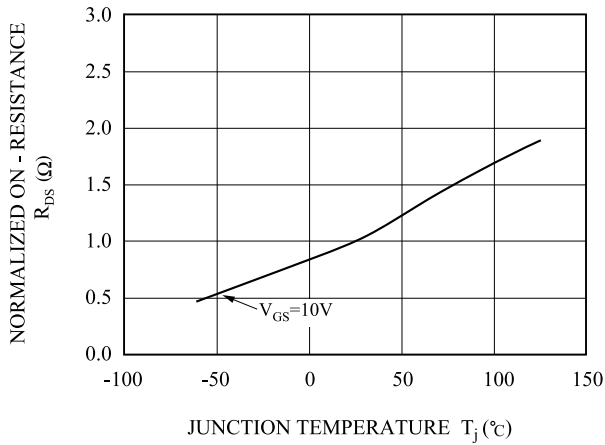

Fig 4. $V_{th} - T_j$

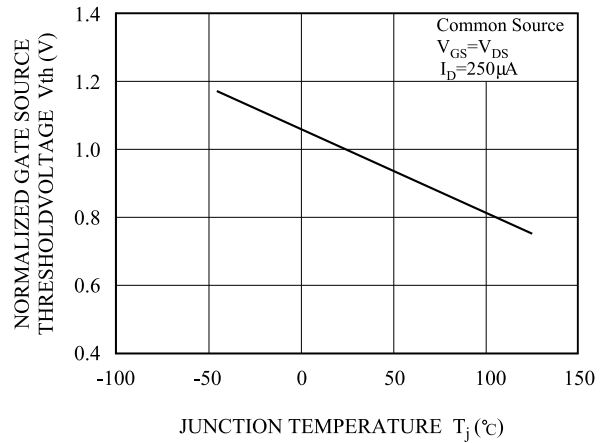

Fig 5. $I_D - V_{GS}$

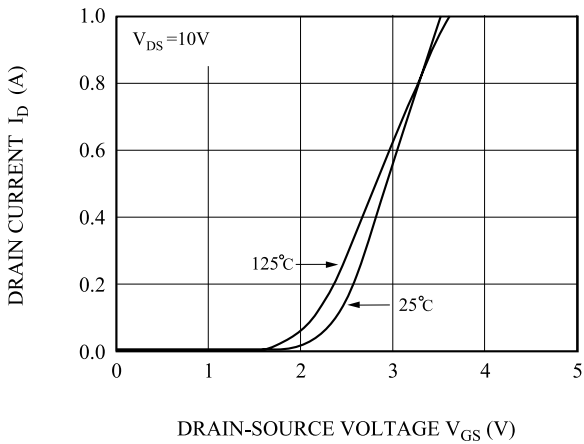
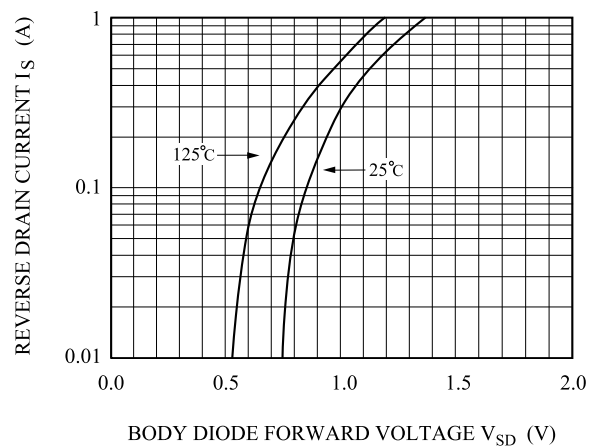

Fig 6. $I_S - V_{SD}$



2N7002KE

Fig 7. C - V_{DS}

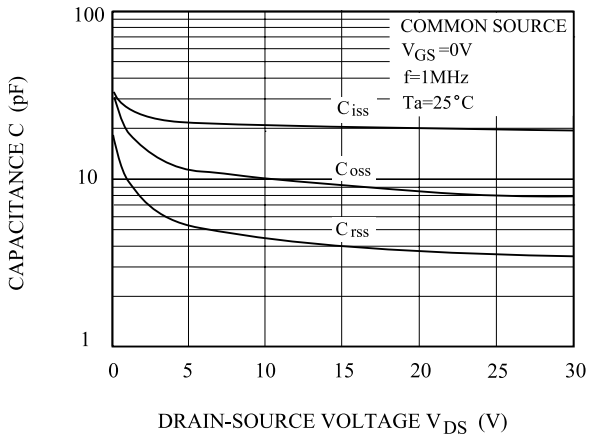

Fig 8. Safe Operation Area

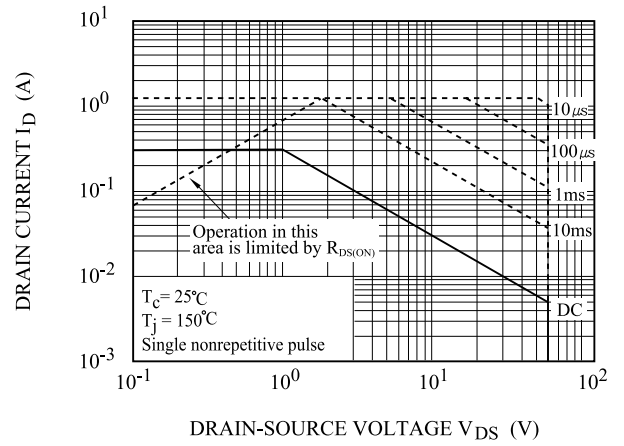

Fig 9. P_D - T_a

