

General Description

This Trench MOSFET has better characteristics, such as fast switching time, low on resistance, low gate charge and excellent avalanche characteristics. It is mainly suitable for DC/DC Converter, Synchronous Rectification and a load switch in battery powered applications

FEATURES

- Split Gate Trench Technology
- Ultra low on-resistance
- Ultra Low gate charge (typ. $Q_g=47.0nC$)
- Periodic avalanche rated
- Fully isolated package ($2500 V_{AC} : 1 \text{ minute}$)
- Pb-free lead plating; RoHS compliant
- Qualified according to JEDEC
- Ideal for high-frequency switching and synchronous rectification

MAIN PARAMETER

V_{DSS}	100	V
$R_{DS(ON)} (Max) @ V_{GS}=10V$	8.6	m
I_D	55	A

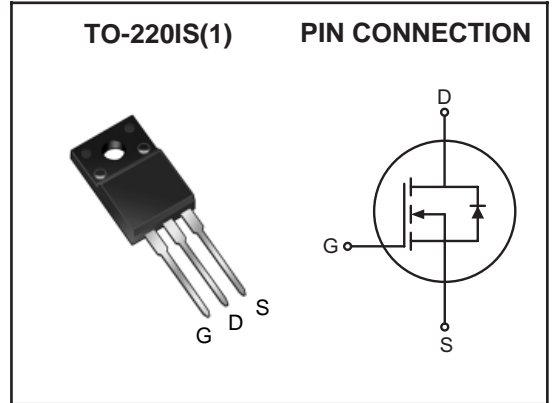

MAXIMUM RATING (Tc=25)

CHARACTERISTIC		SYMBOL	RATING	UNIT
Drain-Source Voltage		V_{DSS}	100	V
Gate-Source Voltage		V_{GSS}	± 20	V
Drain Current	@T _C =25	I_D	55	A
	@T _C =100		35.5	
	Pulsed (Note 1)	I_{DP}	220*	
Single Pulsed Avalanche Energy (Note 2)		E_{AS}	97	mJ
Repetitive Avalanche Energy (Note 1)		E_{AR}	3.3	mJ
Peak Diode Recovery dv/dt (Note 3)		dv/dt	4.5	V/ns
Drain Power Dissipation	T _C =25	P_D	46	W
	Derate above 25		0.37	W/
Maximum Junction Temperature		T_j	150	
Storage Temperature Range		T_{stg}	-55 ~ 150	
Thermal Characteristics				
Thermal Resistance, Junction-to-Case		R_{thJC}	2.7	/W
Thermal Resistance, Junction-to-Ambient		R_{thJA}	62.5	/W

* : Drain current limited by maximum junction temperature.

KUS086N10F

ELECTRICAL CHARACTERISTICS (T_C=25)

CHARACTERISTIC	SYMBOL	TEST CONDITION	MIN.	TYP.	MAX.	UNIT
Static						
Drain-Source Breakdown Voltage	BV _{DSS}	I _D =250 μA, V _{GS} =0V	100	-	-	V
Breakdown Voltage Temperature Coefficient	BV _{DSS} / T _j	I _D =250 μA, Referenced to 25	-	0.05	-	V/
Drain Cut-off Current	I _{DSS}	V _{DS} =100V, V _{GS} =0V,	-	-	10	μA
Gate Threshold Voltage	V _{th}	V _{DS} =V _{GS} , I _D =250 μA	2.0	-	4.0	V
Gate Leakage Current	I _{GSS}	V _{GS} = ± 20V, V _{DS} =0V	-	-	± 100	nA
Drain-Source ON Resistance	R _{DS(ON)}	V _{GS} =10V, I _D =27.5A	-	6	8.6	m
		V _{GS} =6V, I _D =14A	-	-	12	
Dynamic						
Total Gate Charge	Q _g	V _{DS} =80V, I _D =55A V _{GS} =10V (Note4,5)	-	47	-	nC
Gate-Source Charge	Q _{gs}		-	12	-	
Gate-Drain Charge	Q _{gd}		-	10	-	
Turn-on Delay time	t _{d(on)}	V _{DD} =50V I _D =55A R _G =25 (Note4,5)	-	38	-	ns
Turn-on Rise time	t _r		-	32	-	
Turn-off Delay time	t _{d(off)}		-	132	-	
Turn-off Fall time	t _f		-	40	-	
Input Capacitance	C _{iss}	V _{DS} =25V, V _{GS} =0V, f=1.0MHz	-	2970	-	pF
Output Capacitance	C _{oss}		-	1320	-	
Reverse Transfer Capacitance	C _{rss}		-	63	-	
Source-Drain Diode Ratings						
Continuous Source Current	I _S	V _{GS} <V _{th}	-	-	33	A
Pulsed Source Current	I _{SP}		-	-	132	
Diode Forward Voltage	V _{SD}	I _S =33A, V _{GS} =0V	-	-	1.4	V
Reverse Recovery Time	t _{rr}	I _S =55A, V _{GS} =0V,	-	67	-	ns
Reverse Recovery Charge	Q _{rr}	dI _S /dt=100A/ μs	-	0.18	-	μC

Note 1) Repetivity rating : Pulse width limited by junction temperature.

Note 2) L = 37 μH, I_S=55A, V_{DD}=50V, R_G=25 , Starting T_j=25 .

Note 3) I_S 55A, V_{DD} BV_{DSS}, Starting T_j=25 .

Note 4) Pulse Test : Pulse width 300 μs, Duty Cycle 2%.

Note 5) Essentially independent of operating temperature.

MARKING

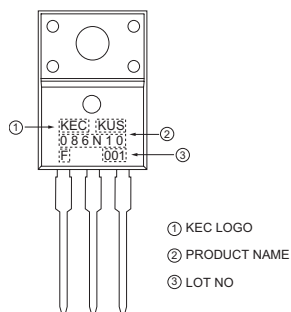

KUS086N10F

Fig1. $I_D - V_{DS} - I$

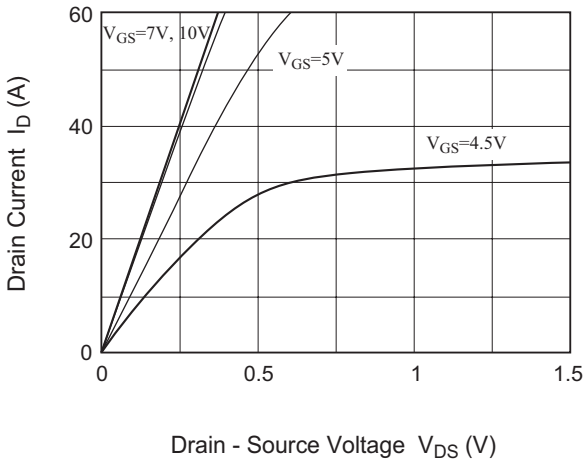

Fig2. $I_D - V_{DS} - II$

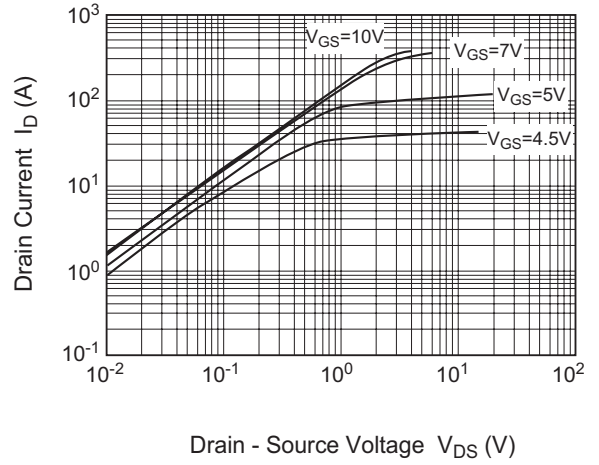

Fig3. $I_D - V_{GS}$

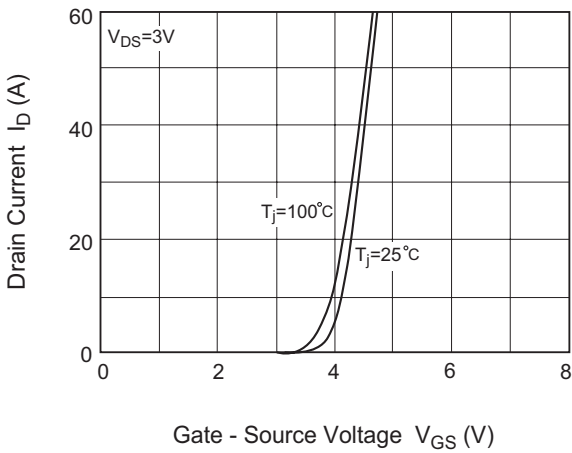

Fig4. $R_{DS(ON)} - I_D$

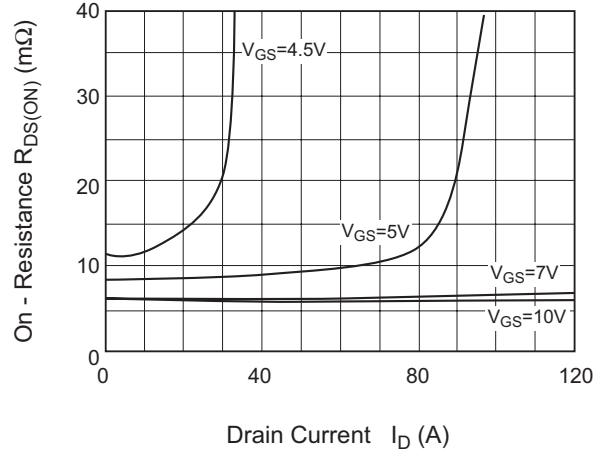

Fig5. $R_{DS(ON)} - V_{GS}$

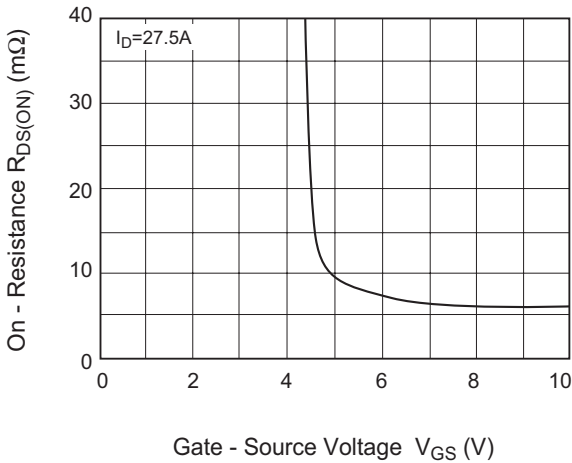
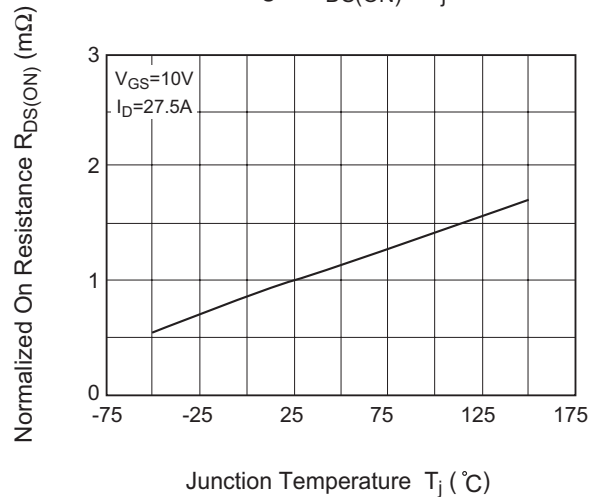

Fig6. $R_{DS(ON)} - T_j$



KUS086N10F

Fig7. $BV_{DSS} - T_j$

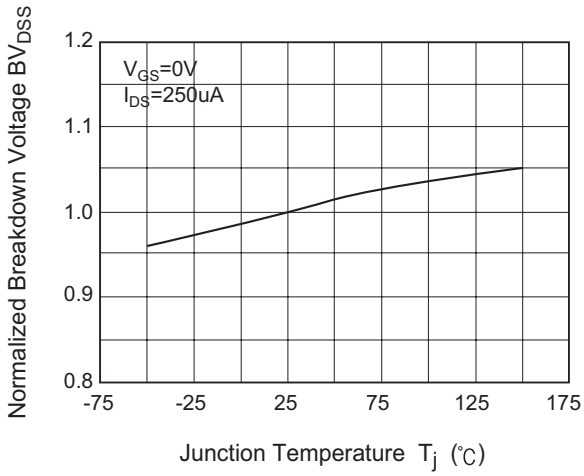

Fig8. $V_{th} - T_j$

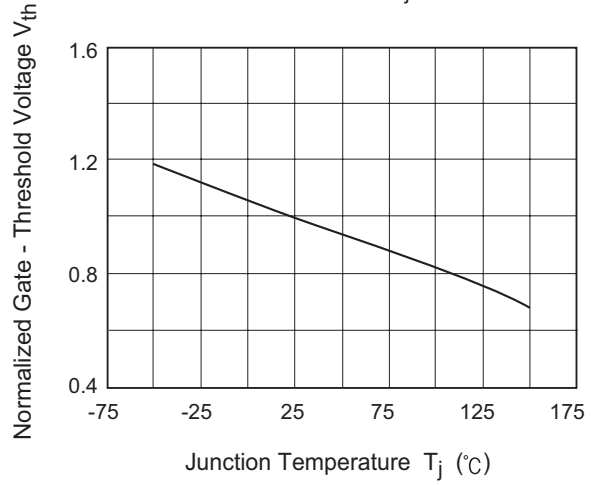

Fig 9. $I_S - V_{SD} - I$

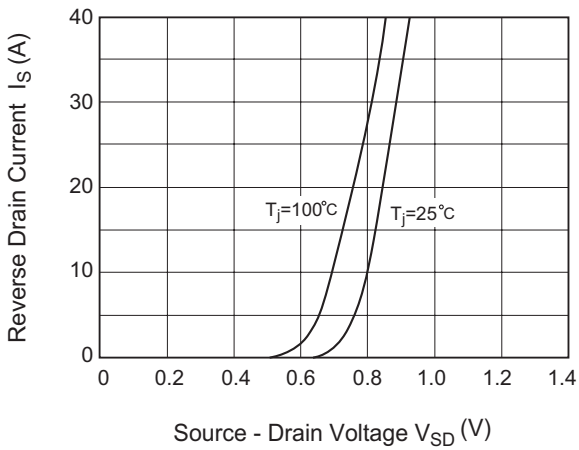

Fig10. $I_S - V_{SD} - II$

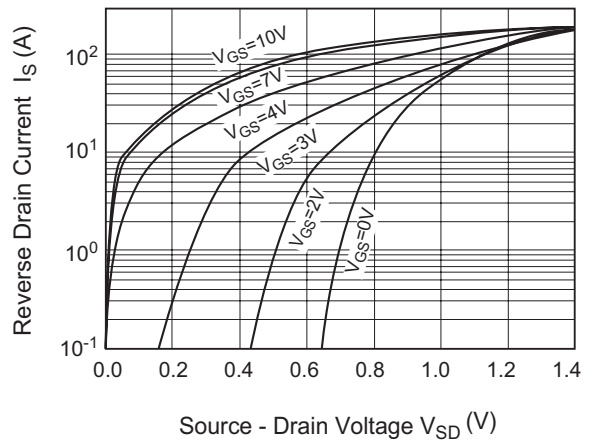

Fig11. $C - V_{DS}$

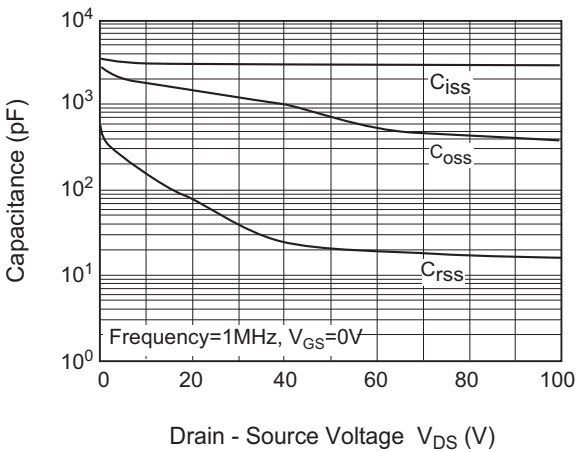
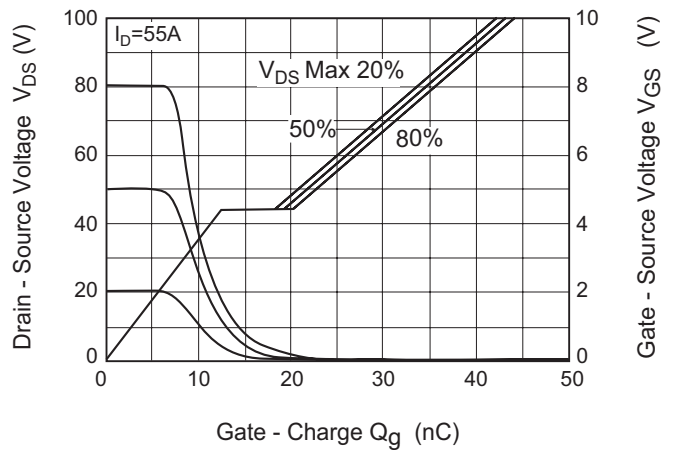

Fig12. $Q_g - V_{GS}$



KUS086N10F

Fig13. $I_D - T_j$

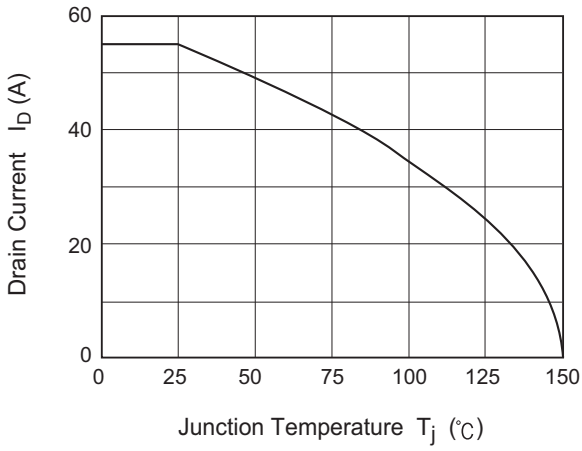

Fig14. $P_{tot} - T_C$

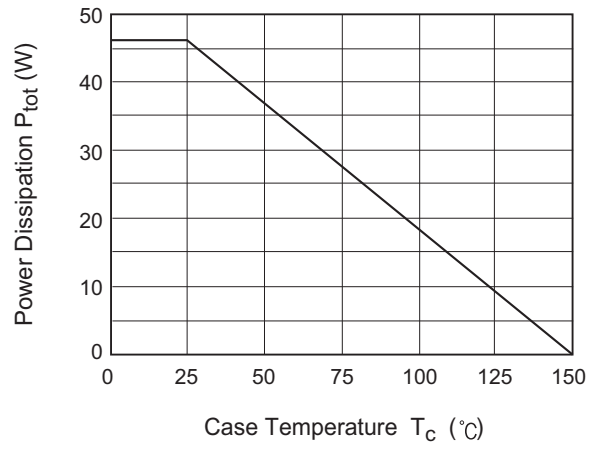

Fig15. S/W Time - I_D

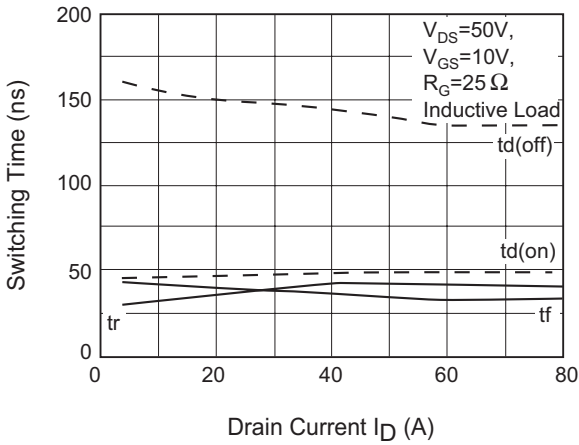

Fig16. S/W Loss - I_D

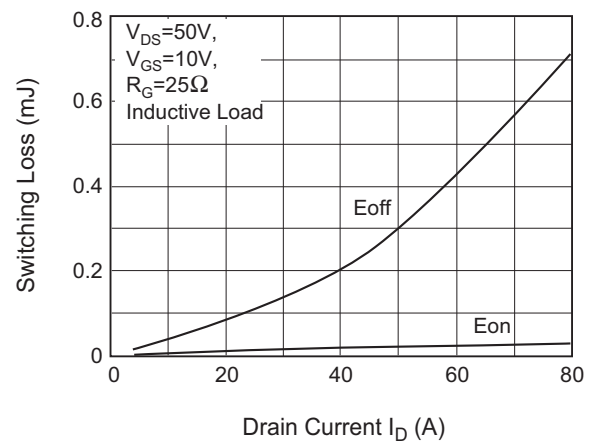

Fig17. S/W Time - R_G

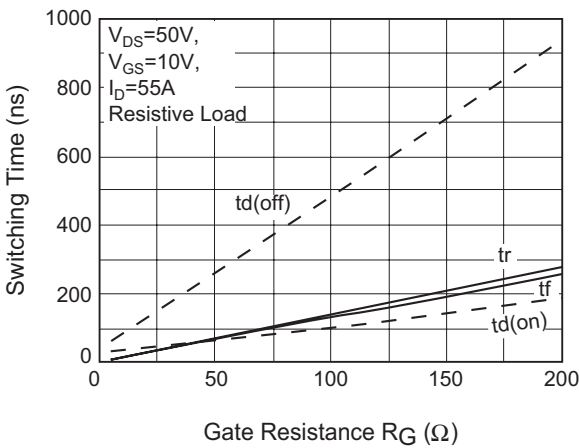
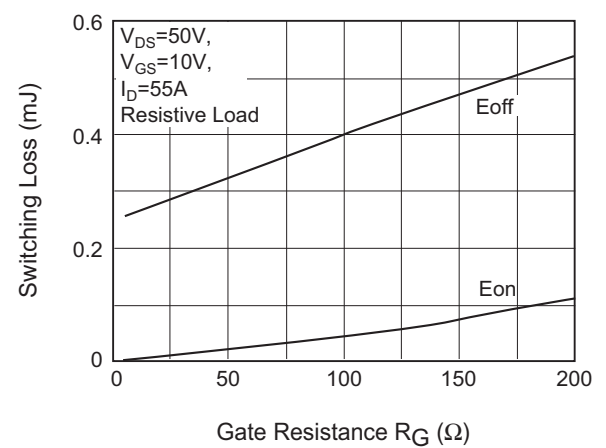

Fig18. S/W Loss - R_G



KUS086N10F

Fig 19. Safe Operation Area

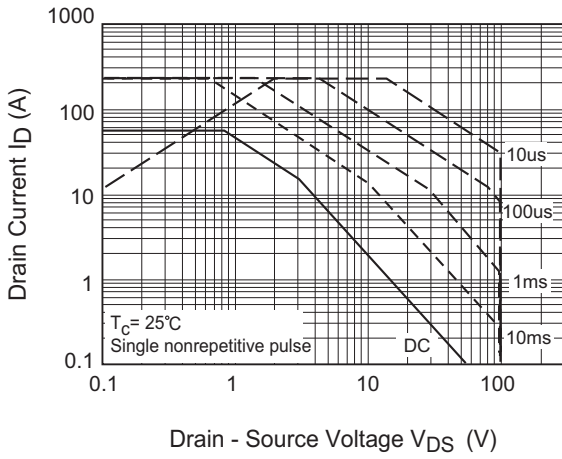

Fig20. Transient Thermal Response Curve (Junction - Case)

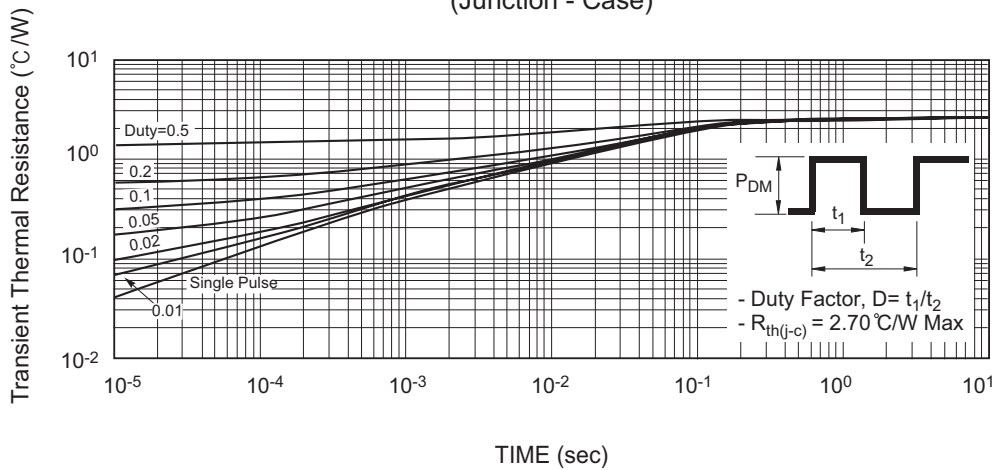

Fig21. Transient Thermal Response Curve (Junction - Ambient)

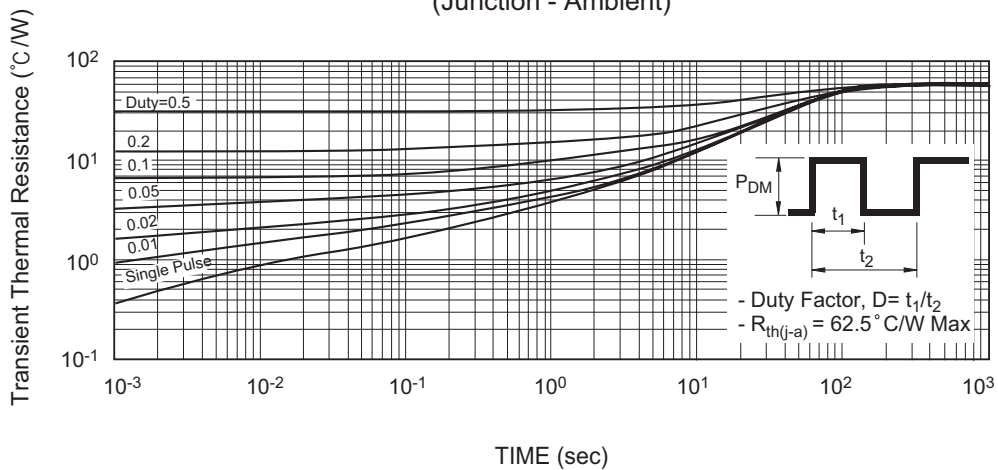

Fig22. Gate Charge

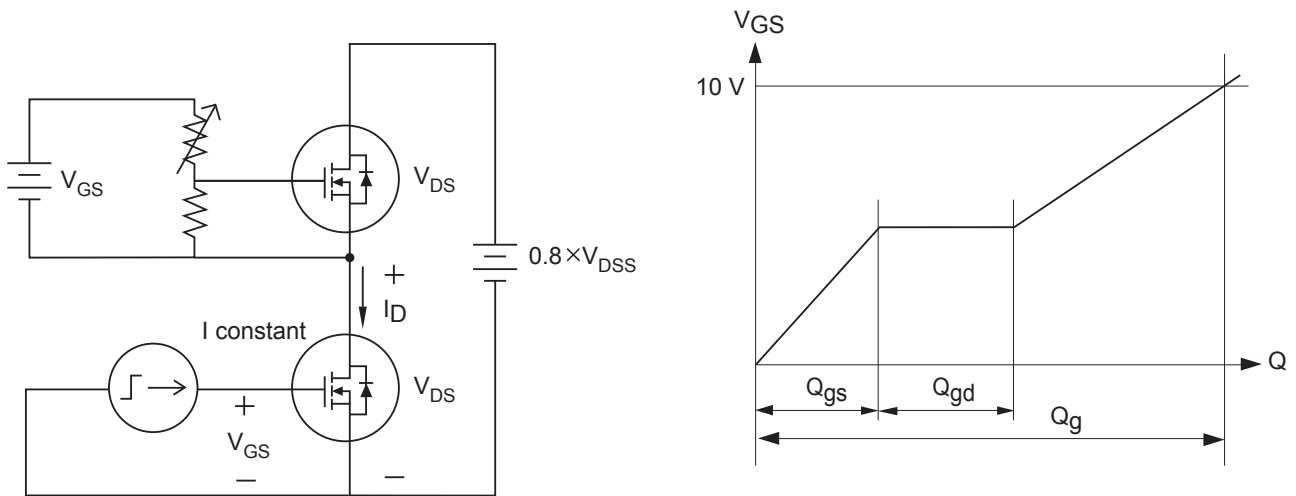

Fig23. Single Pulsed Avalanche Energy

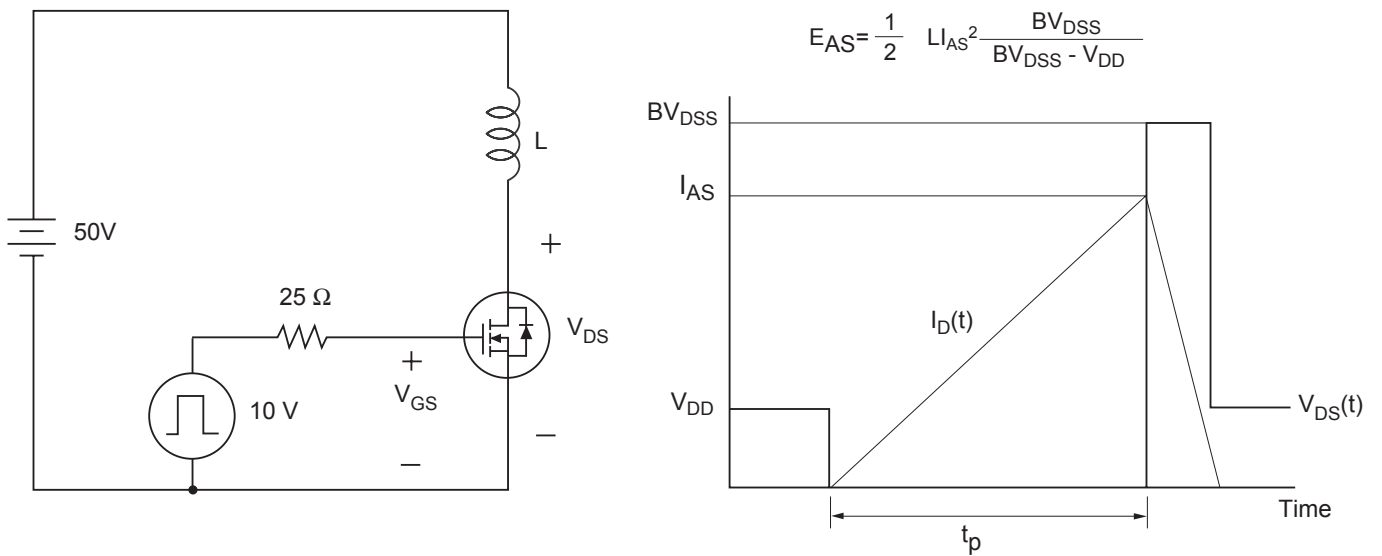

Fig24. Resistive Load Switching

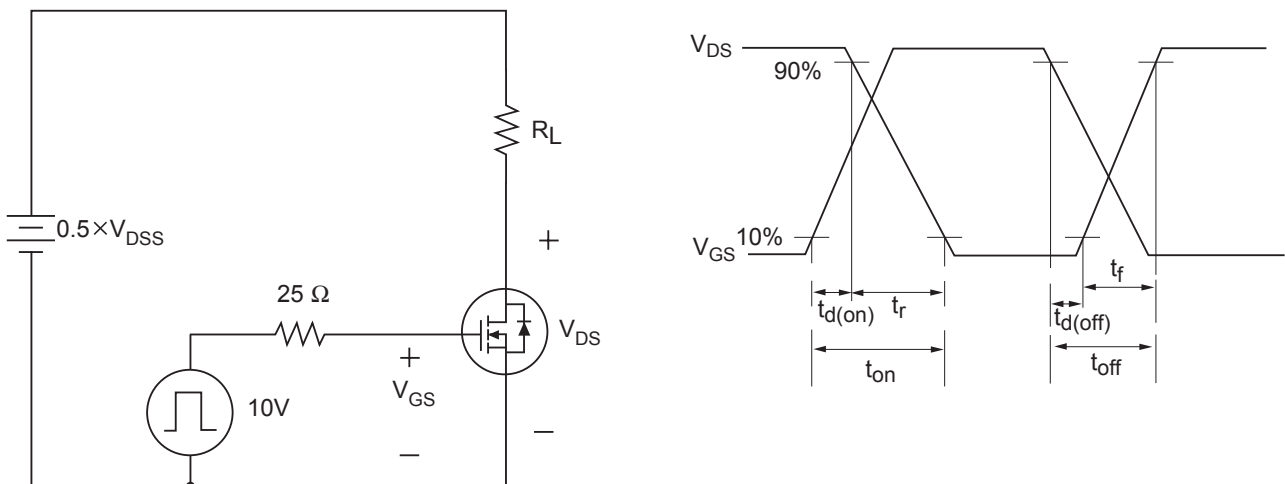
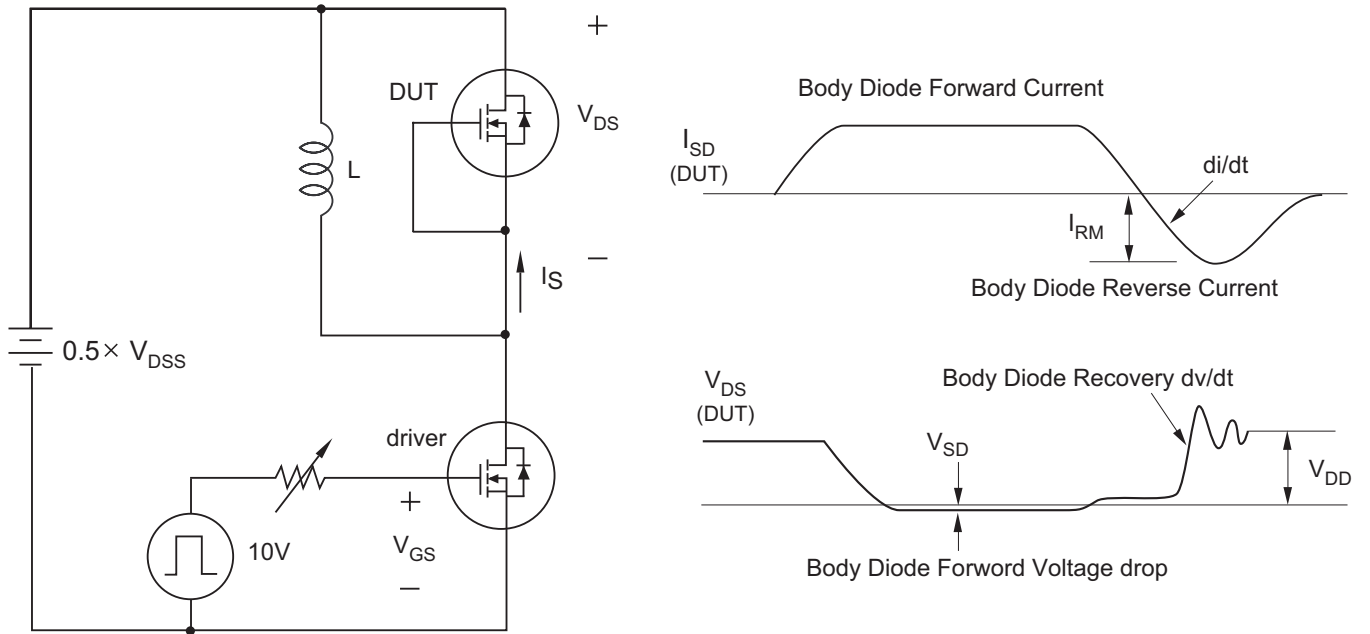

Fig25. Source - Drain Diode Reverse Recovery and dv/dt



KUS086N10F

PACKAGE OUTLINE

