

General Description

This Trench MOSFET has better characteristics, such as fast switching time, low on resistance, low gate charge and excellent avalanche characteristics. It is mainly suitable for DC/DC Converter, Synchronous Rectification and a load switch in battery powered applications

FEATURES

- $V_{DSS} = 100V$, $I_D = 30A$
- Drain-Source ON Resistance :
 $R_{DS(ON)} = 22m$ (Max.) @ $V_{GS} = 10V$

MAXIMUM RATING (Tc=25 °C)

CHARACTERISTIC		SYMBOL	RATING	UNIT
Drain-Source Voltage		V_{DSS}	100	V
Gate-Source Voltage		V_{GSS}	± 20	V
Drain Current	@T _C =25	I_D	30	A
	@T _C =100		19	
	@T _a =25		10	
	Pulsed (Note1)		I_{DP}	
Single Pulsed Avalanche Energy (Note 2)		E_{AS}	42	mJ
Repetitive Avalanche Energy (Note 1)		E_{AR}	2.2	mJ
Peak Diode Recovery dv/dt (Note 3)		dv/dt	4.5	V/ns
Drain Power Dissipation	T _c =25	P_D	36.7	W
	Derate above 25		0.29	W/
	@T _a =25		4.1	W
Maximum Junction Temperature		T_j	150	
Storage Temperature Range		T_{stg}	-55 ~ 150	
Thermal Characteristics				
Thermal Resistance, Junction-to-Case		R_{thJC}	3.4	/W
Thermal Resistance, Junction-to-Ambient		R_{thJA}	30*	/W

* : Surface mounted on 25mm x 25mm FR4 Board, t = 10 sec.

PIN CONNECTION

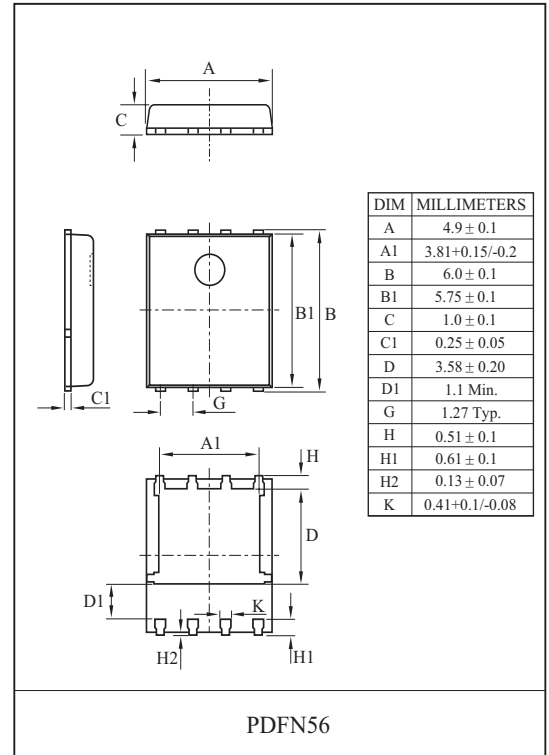
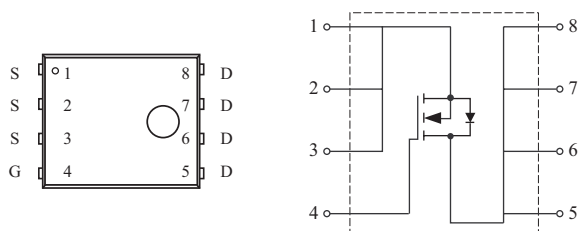

KUS220N10C

ELECTRICAL CHARACTERISTICS (Tc=25)

CHARACTERISTIC	SYMBOL	TEST CONDITION	MIN.	TYP.	MAX.	UNIT
Static						
Drain-Source Breakdown Voltage	BV_{DSS}	$I_D=250\ \mu A, V_{GS}=0V$	100	-	-	V
Breakdown Voltage Temperature Coefficient	BV_{DSS}/T_j	$I_D=5mA$, Referenced to 25	-	0.05	-	V/
Drain Cut-off Current	I_{DSS}	$V_{DS}=100V, V_{GS}=0V$,	-	-	10	μA
Gate Threshold Voltage	V_{th}	$V_{DS}=V_{GS}, I_D=250\ \mu A$	2.0	-	4.0	V
Gate Leakage Current	I_{GSS}	$V_{GS}=\pm 20V, V_{DS}=0V$	-	-	± 100	nA
Drain-Source ON Resistance	$R_{DS(ON)}$	$V_{GS}=10V, I_D=15A$	-	17	22	m
Dynamic						
Total Gate Charge	Q_g	$V_{DS}=80V, I_D=30A$ $V_{GS}=10V$ (Note4,5)	-	17	-	nC
Gate-Source Charge	Q_{gs}		-	4.2	-	
Gate-Drain Charge	Q_{gd}		-	4.1	-	
Turn-on Delay time	$t_{d(on)}$	$V_{DD}=50V$ $I_D=30A$ $R_G=25$ (Note4,5)	-	18	-	ns
Turn-on Rise time	t_r		-	22	-	
Turn-off Delay time	$t_{d(off)}$		-	46	-	
Turn-off Fall time	t_f		-	17	-	
Input Capacitance	C_{iss}	$V_{DS}=25V, V_{GS}=0V, f=1.0MHz$	-	1060	-	pF
Output Capacitance	C_{oss}		-	390	-	
Reverse Transfer Capacitance	C_{rss}		-	39	-	
Source-Drain Diode Ratings						
Continuous Source Current	I_S	$V_{GS}<V_{th}$	-	-	26	A
Pulsed Source Current	I_{SP}		-	-	104	
Diode Forward Voltage	V_{SD}	$I_S=26A, V_{GS}=0V$	-	-	1.4	V
Reverse Recovery Time	t_{rr}	$I_S=30A, V_{GS}=0V$, $dI_S/dt=100A/\mu s$	-	51	-	ns
Reverse Recovery Charge	Q_{rr}		-	0.11	-	μC

Note 1) Repetivity rating : Pulse width limited by junction temperature.

Note 2) $L=53\ \mu H, I_S=30A, V_{DD}=50V, R_G=25$, Starting $T_j=25$.

Note 3) $I_S=32A, V_{DD}=BV_{DSS}$, Starting $T_j=25$.

Note 4) Pulse Test : Pulse width $300\ \mu s$, Duty Cycle 2% .

Note 5) Essentially independent of operating temperature.

Marking

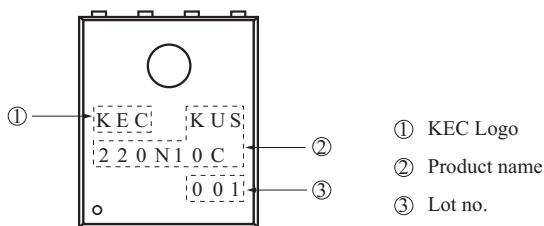

KUS220N10C

Fig1. $I_D - V_{DS}$

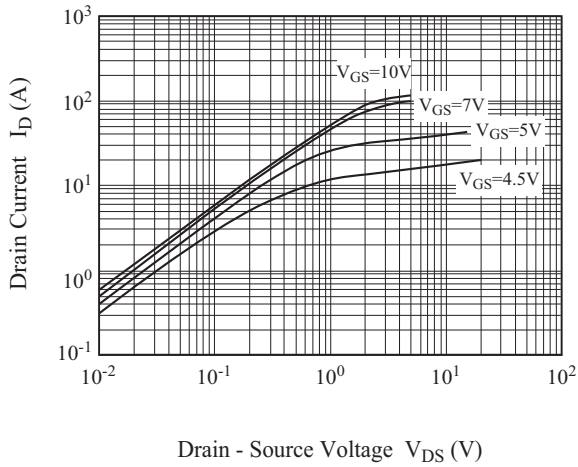

Fig2. $I_D - V_{GS}$

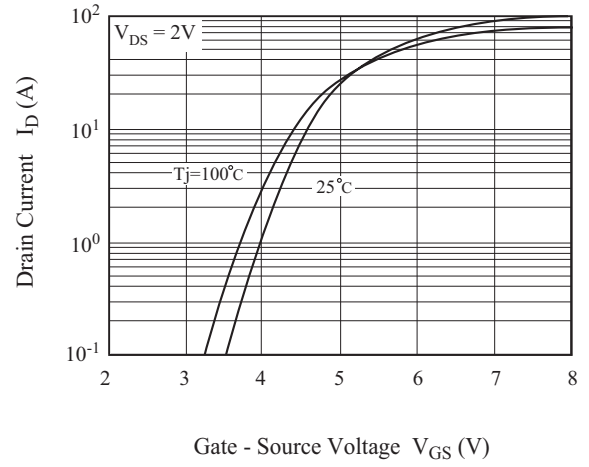

Fig3. $BV_{DSS} - T_j$

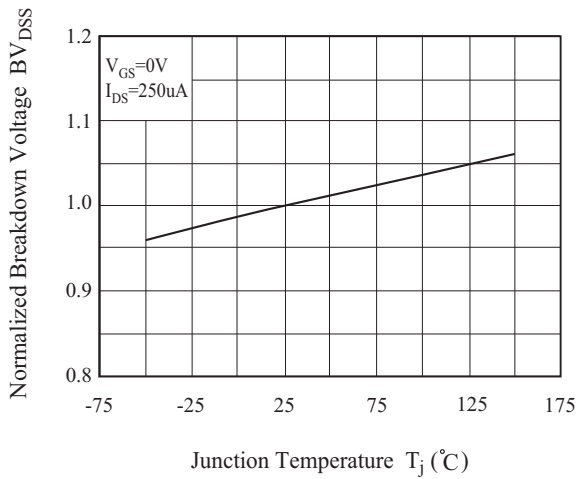

Fig4. $R_{DS(ON)} - T_j$

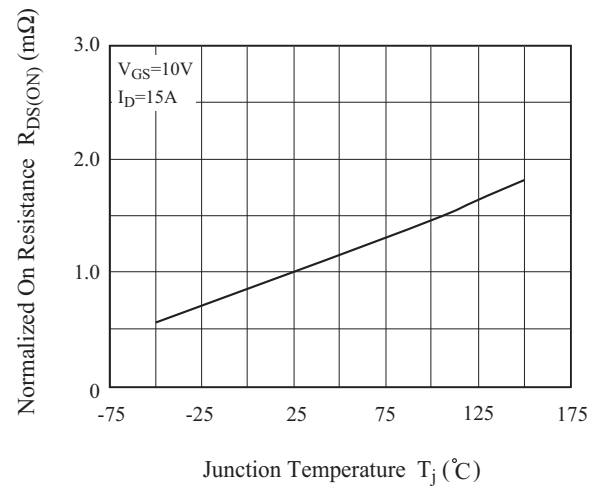

Fig5. $I_S - V_{SD} - I$

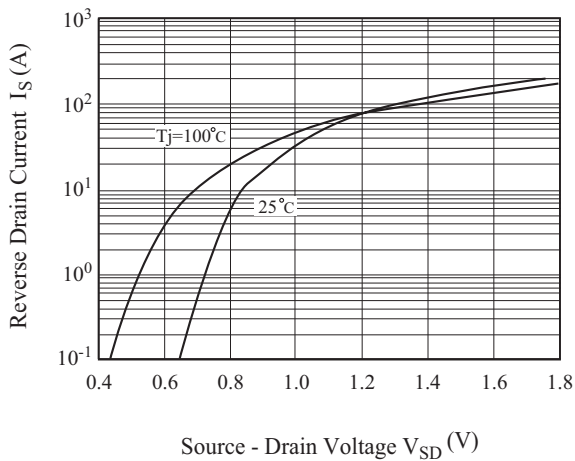

Fig6. $I_S - V_{SD} - II$

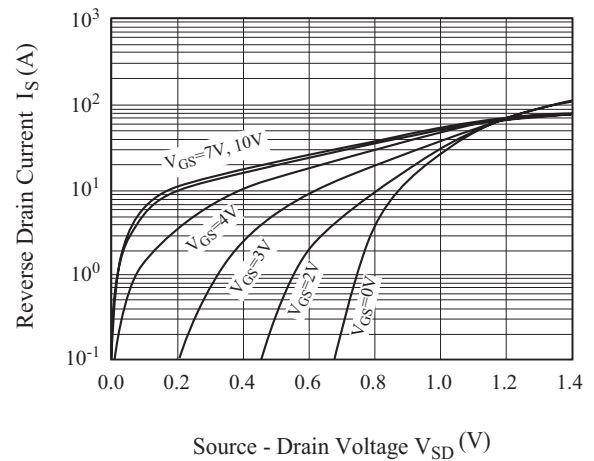

Fig7. $R_{DS(ON)} - I_D$

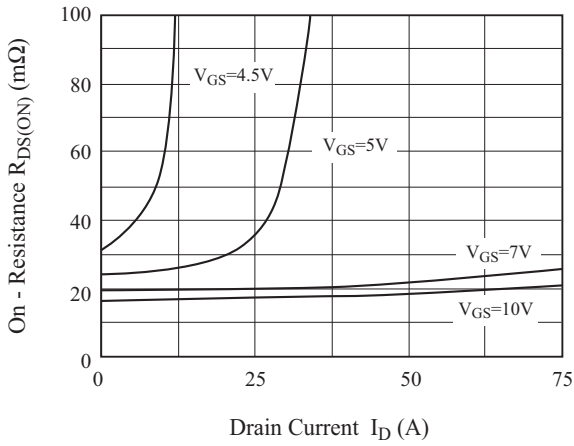

Fig8. $V_{th} - T_j$

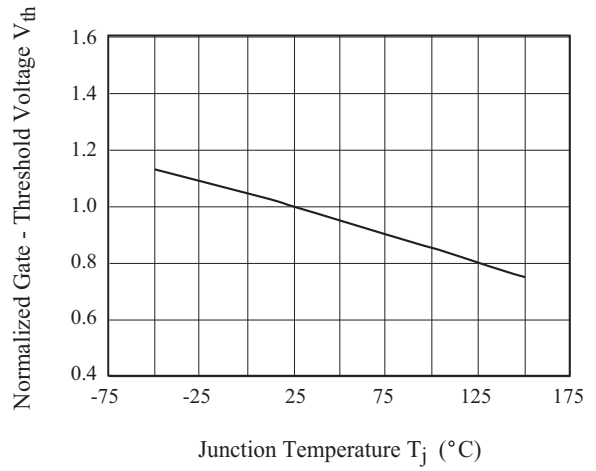

Fig 9. $C - V_{DS}$

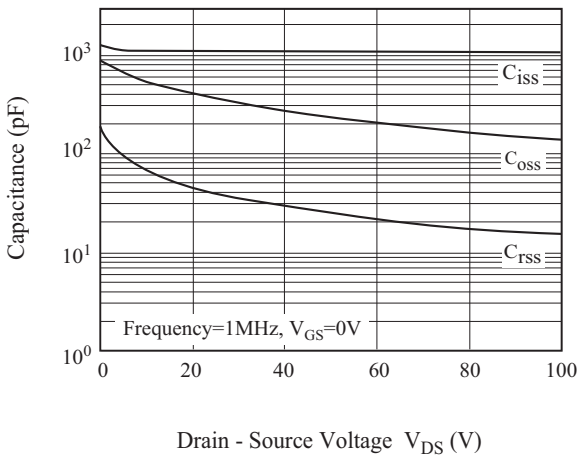

Fig10. $Q_g - V_{GS}$

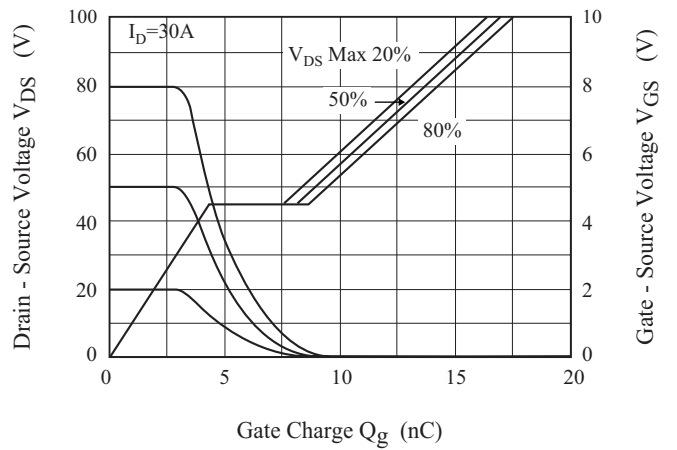

Fig11. $I_D - T_j$

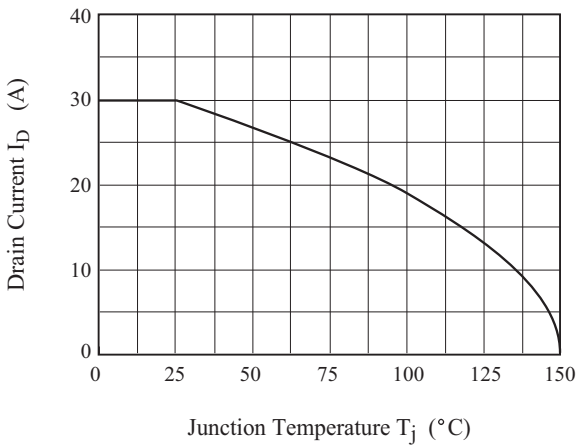
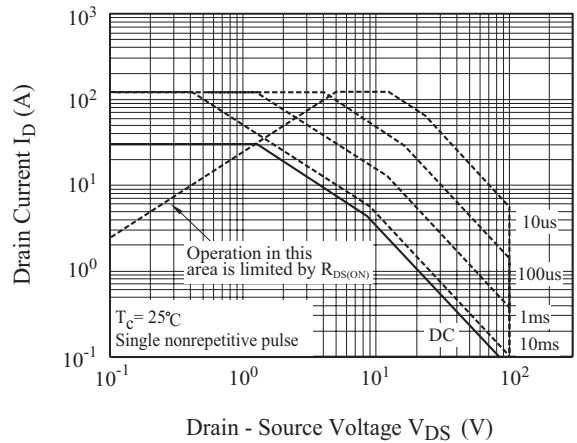

Fig12. Safe Operation Area



KUS220N10C

Fig13. Transient Thermal Response Curve



Fig14. Gate Charge

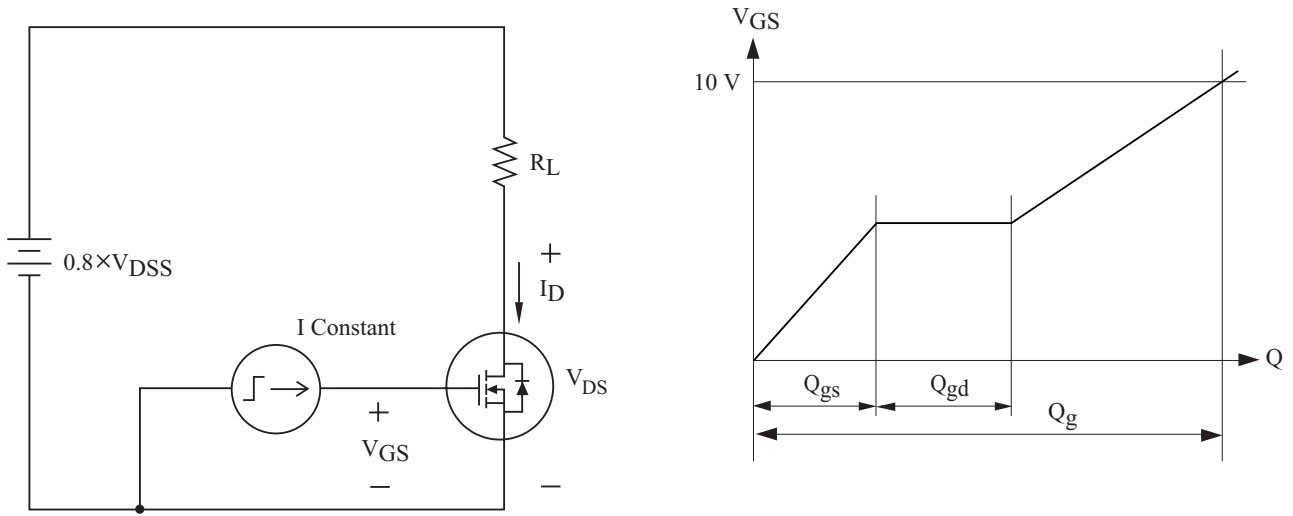

Fig15. Single Pulsed Avalanche Energy

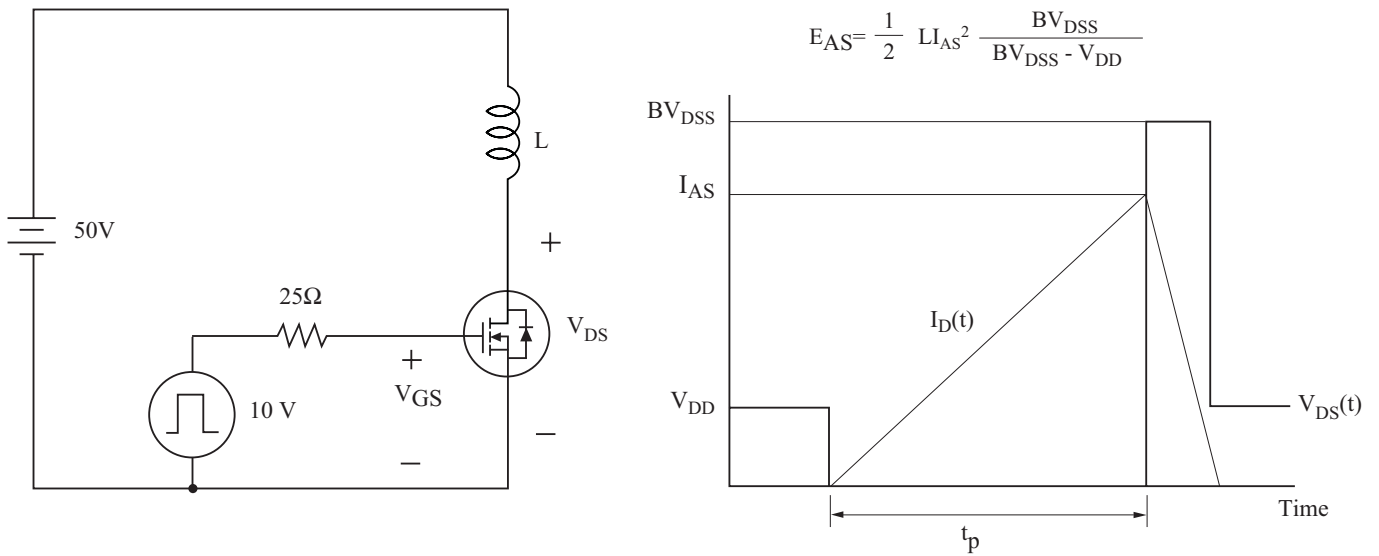

Fig16. Resistive Load Switching

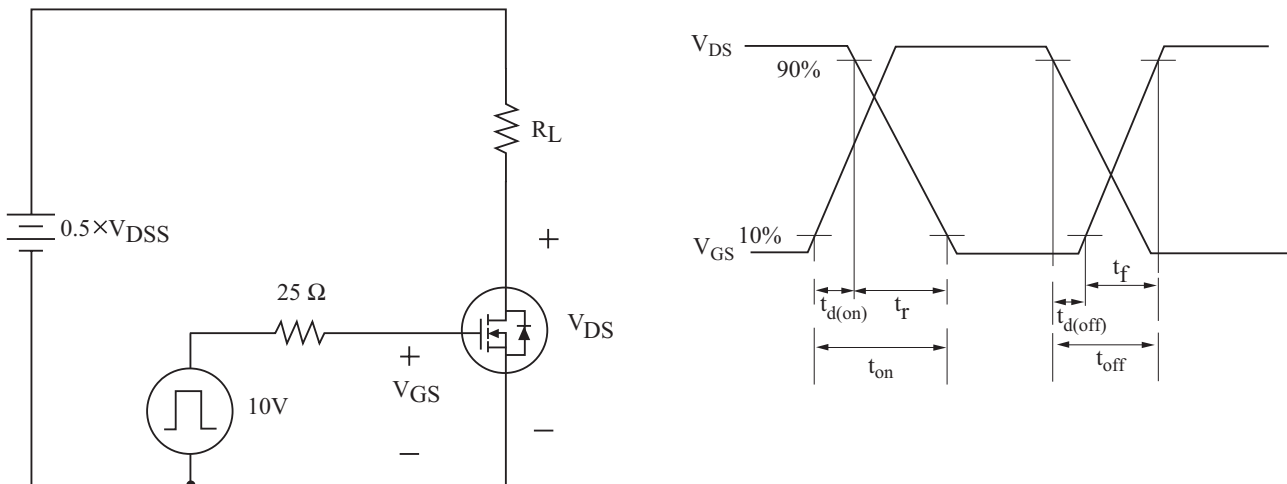
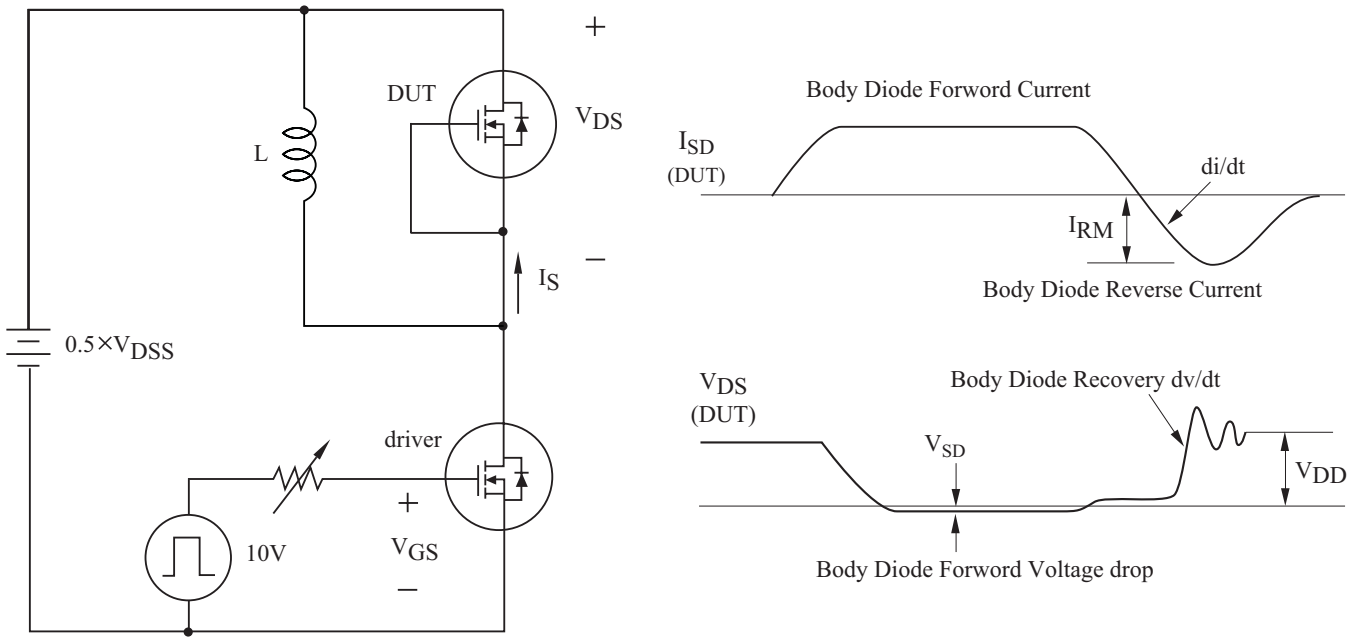

Fig17. Source - Drain Diode Reverse Recovery and dv/dt



KUS220N10C

Fig 18. Recommended Pad Dimension

