

## General Description

This Trench MOSFET has better characteristics, such as fast switching time, low on resistance, low gate charge and excellent avalanche characteristics. It is mainly suitable for LED Lighting and DC/DC Converters.

## FEATURES

- $V_{DSS(Min.)} = 100V$ ,  $I_D = 1.3A$
- Drain-Source ON Resistance :  $R_{DS(ON)} = 0.36$  (max) @  $V_{GS} = 10V$
- $Q_g(\text{typ.}) = 4.5nC$

## MAXIMUM RATING ( $T_a = 25^\circ C$ )

CHARACTERISTIC	SYMBOL	RATING	UNIT
Drain-Source Voltage	$V_{DSS}$	100	V
Gate-Source Voltage	$V_{GSS}$	$\pm 18$	V
Drain Current	@ $T_a = 25$	$I_D$	1.3*
	@ $T_a = 100$		0.8*
	Pulsed (Note1)	$I_{DP}$	5.2*
Peak Diode Recovery dv/dt (Note 2)	dv/dt	4.5	V/ns
Drain Power Dissipation	$T_a = 25$	$P_D$	1.25*
	Derate above 25		0.01
Maximum Junction Temperature	$T_j$	150	
Storage Temperature Range	$T_{stg}$	-55 ~ 150	
<b>Thermal Characteristics</b>			
Thermal Resistance, Junction-to-Ambient	$R_{thJA}$	100*	/W

\* : Surface Mounted on 2" x 2" FR4 Board 4 ~ 10sec.

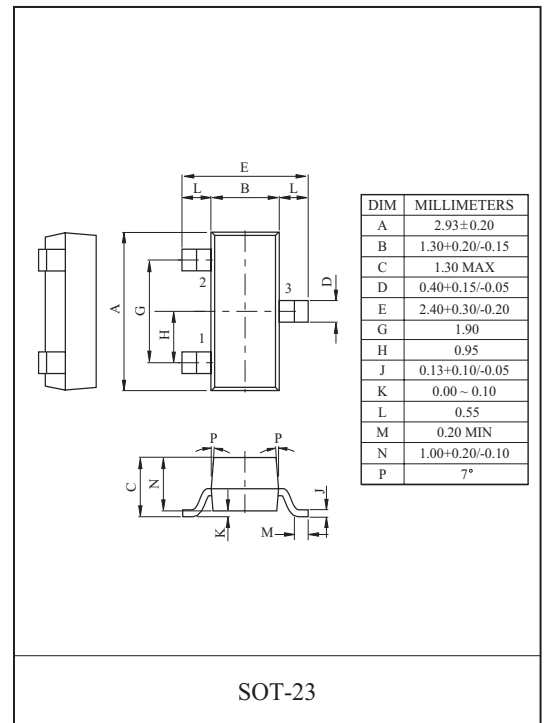

## PIN CONNECTION

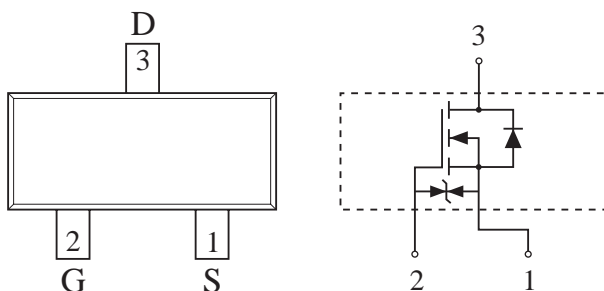

# KU3600N10SZ

## ELECTRICAL CHARACTERISTICS (T<sub>a</sub>=25 °C)

CHARACTERISTIC	SYMBOL	TEST CONDITION	MIN.	TYP.	MAX.	UNIT	
<b>Static</b>							
Drain-Source Breakdown Voltage	BV <sub>DSS</sub>	I <sub>D</sub> =250 μA, V <sub>GS</sub> =0V	100	-	-	V	
Breakdown Voltage Temperature Coefficient	BV <sub>DSS</sub> / T <sub>j</sub>	I <sub>D</sub> =250 μA, Referenced to 25	-	0.1	-	V/	
Drain Cut-off Current	I <sub>DSS</sub>	V <sub>DS</sub> =100V, V <sub>GS</sub> =0V,	-	-	10	μA	
Gate Threshold Voltage	V <sub>th</sub>	V <sub>DS</sub> =V <sub>GS</sub> , I <sub>D</sub> =250 μA	1.0	-	2.5	V	
Gate Leakage Current	I <sub>GSS</sub>	V <sub>GS</sub> =± 16V, V <sub>DS</sub> =0V	-	-	± 10	μA	
Drain-Source ON Resistance	R <sub>DS(ON)</sub>	V <sub>GS</sub> =10V, I <sub>D</sub> =0.6A	-	0.30	0.36		
		V <sub>GS</sub> =4.5V, I <sub>D</sub> =0.6A		-	0.44		
<b>Dynamic</b>							
Total Gate Charge	V <sub>GS</sub> =10V	Q <sub>g</sub>	V <sub>DS</sub> =50V, I <sub>D</sub> =1.3A V <sub>GS</sub> =10V (Note3,4)	-	4.5	-	nC
	V <sub>GS</sub> =4.5V			-	2.3	-	
Gate-Source Charge	Q <sub>gs</sub>			-	0.6	-	
Gate-Drain Charge	Q <sub>gd</sub>			-	1.2	-	
Turn-on Delay time	t <sub>d(on)</sub>	t <sub>d(on)</sub>	V <sub>DD</sub> =50V, I <sub>D</sub> =1.3A R <sub>G</sub> =6 V <sub>GS</sub> =10V (Note3,4)	-	10	-	ns
Turn-on Rise time	t <sub>r</sub>			-	5	-	
Turn-off Delay time	t <sub>d(off)</sub>			-	35	-	
Turn-off Fall time	t <sub>f</sub>			-	6	-	
Input Capacitance	C <sub>iss</sub>	C <sub>iss</sub>	V <sub>DS</sub> =25V, V <sub>GS</sub> =0V, f=1.0MHz	-	210	-	pF
Output Capacitance	C <sub>oss</sub>			-	30	-	
Reverse Transfer Capacitance	C <sub>rss</sub>			-	13	-	
<b>Source-Drain Diode Ratings</b>							
Continuous Source Current	I <sub>S</sub>	I <sub>S</sub>	V <sub>GS</sub> <V <sub>th</sub>	-	-	0.9	A
Pulsed Source Current	I <sub>SP</sub>			-	-	3.6	
Diode Forward Voltage	V <sub>SD</sub>	I <sub>S</sub> =0.9A, V <sub>GS</sub> =0V		-	-	1.4	V
Reverse Recovery Time	t <sub>rr</sub>	I <sub>S</sub> =1.3A, V <sub>GS</sub> =0V, dI <sub>S</sub> /dt=100A/μs		-	30	-	ns
Reverse Recovery Charge	Q <sub>rr</sub>			-	40	-	nC

Note 1) Repetivity rating : Pulse width limited by junction temperature.

Note 2) I<sub>S</sub> 1.3A, dI/dt 100A/μs, V<sub>DD</sub> BV<sub>DSS</sub>, Starting T<sub>j</sub>= 25 °C.

Note 3) Pulse Test : Pulse width 300μs, Duty Cycle 2%.

Note 4) Essentially independent of operating temperature.

## Marking

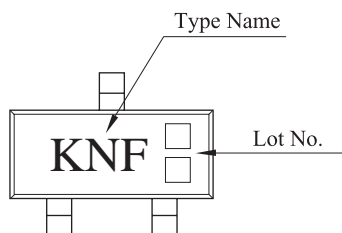

Fig1.  $V_{DS} - I_D$

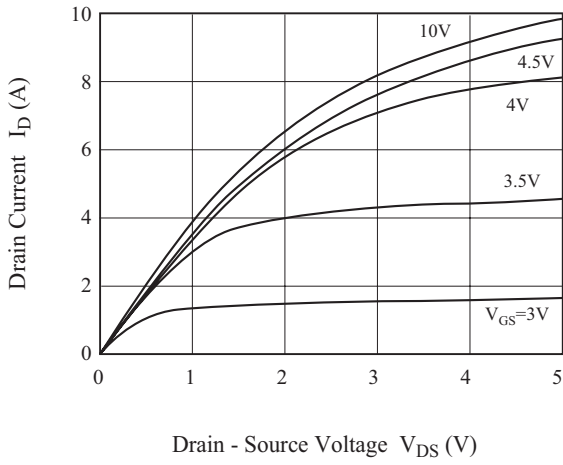

Fig2.  $R_{DS(ON)} - I_D$

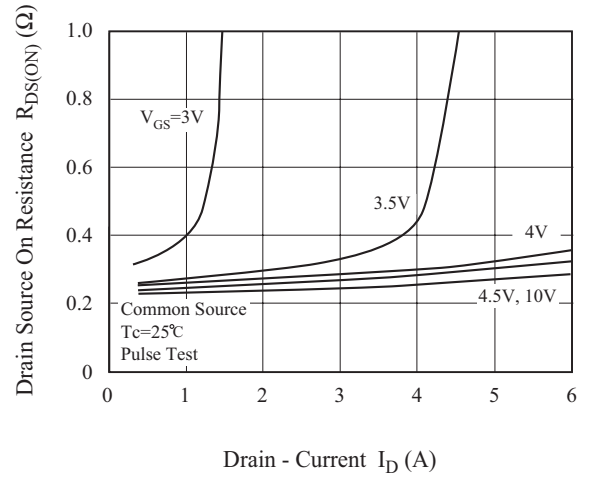

Fig3.  $I_D - V_{GS}$

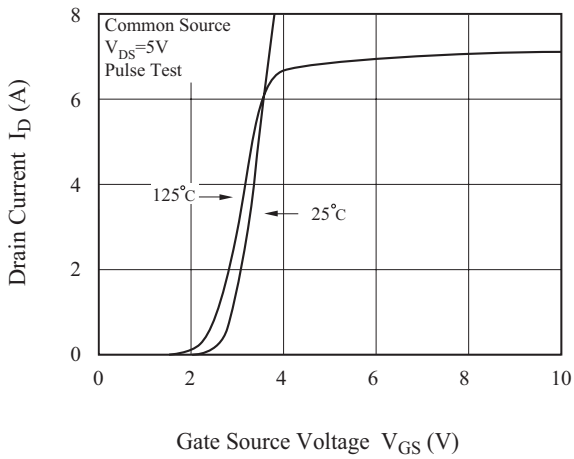

Fig4.  $R_{DS(ON)} - T_j$

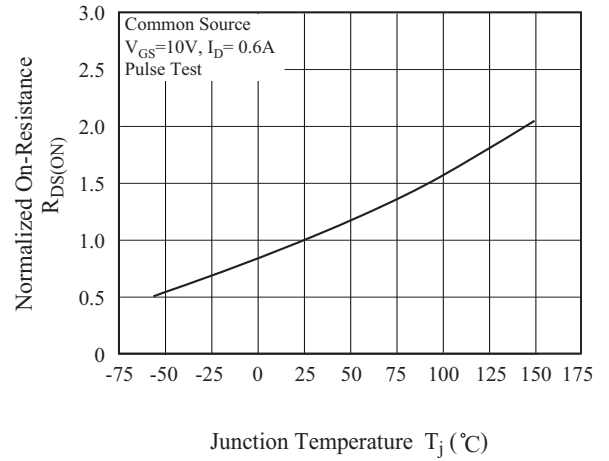

Fig5.  $V_{th} - T_j$

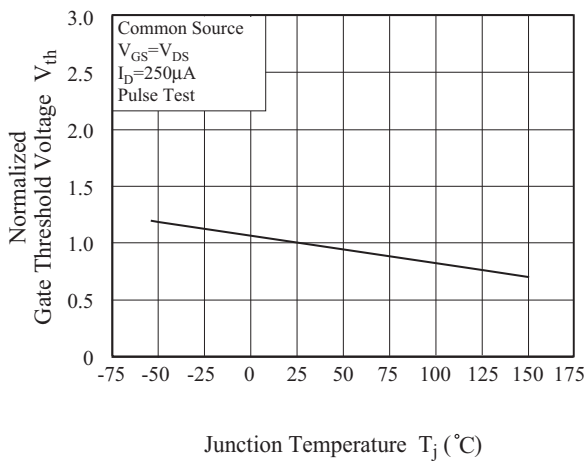
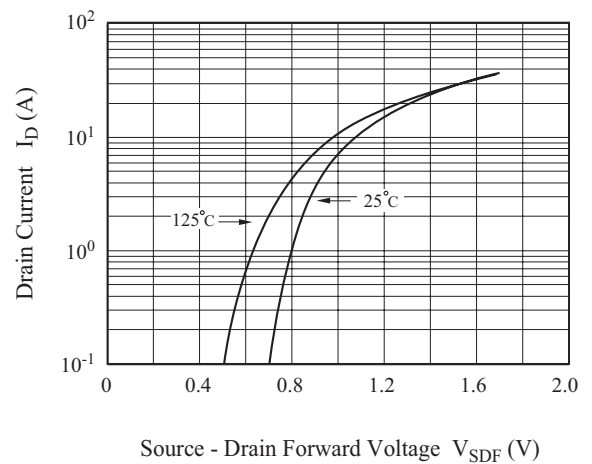

Fig6.  $I_S - V_{SDF}$



# KU3600N10SZ

Fig7.  $BV_{DSS} - T_j$

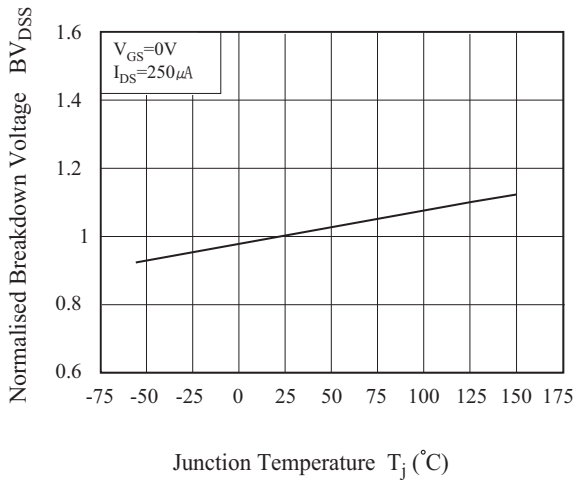

Fig8.  $C - V_{DS}$

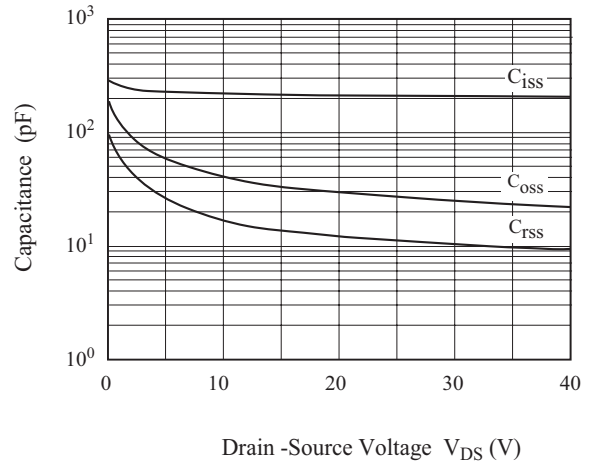

Fig9.  $Q_g - V_{GS}$

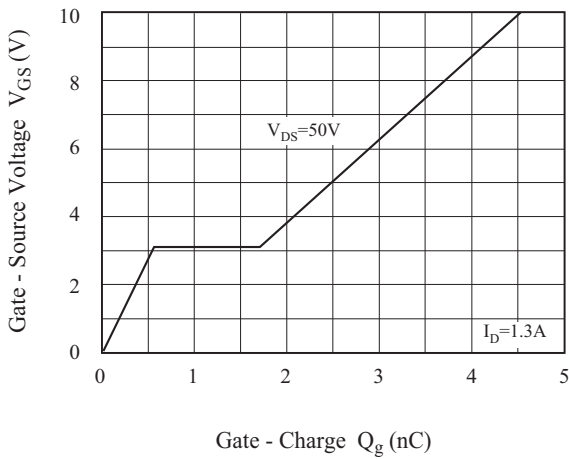

Fig10. Safe Operation Area

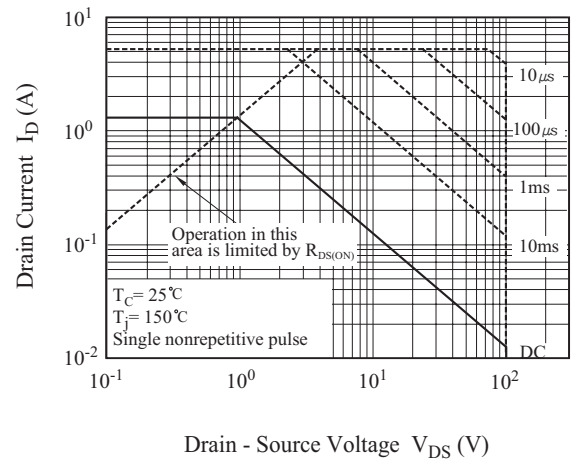

Fig11. Transient Thermal Response Curve

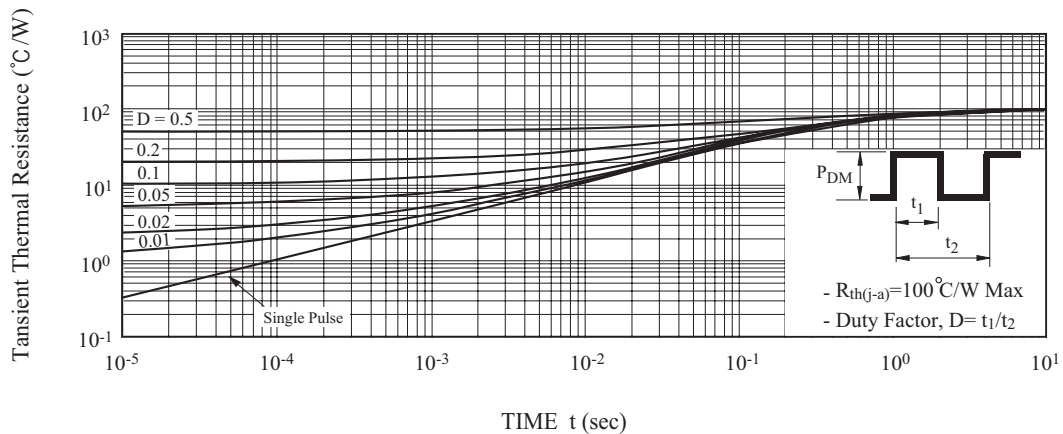

Fig12. Gate Charge

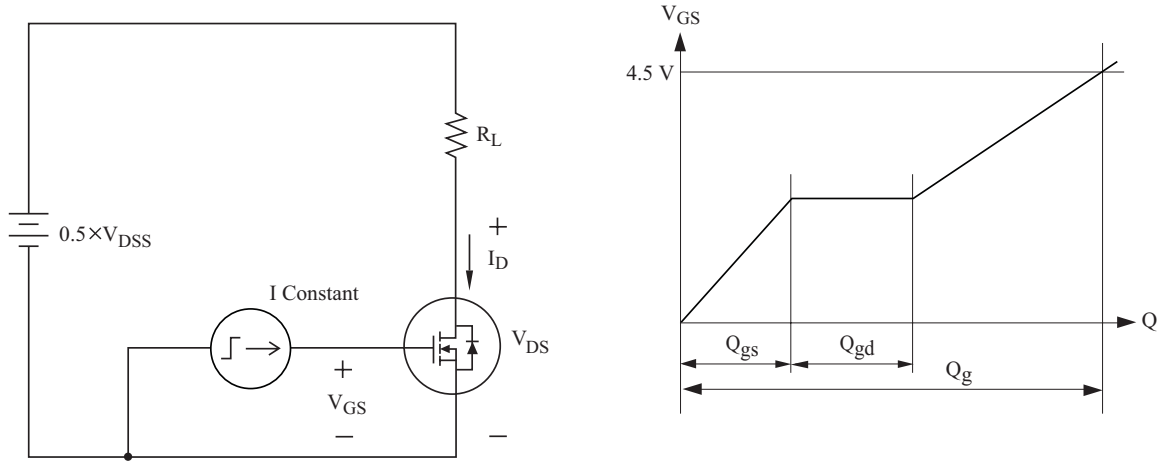

Fig13. Resistive Load Switching

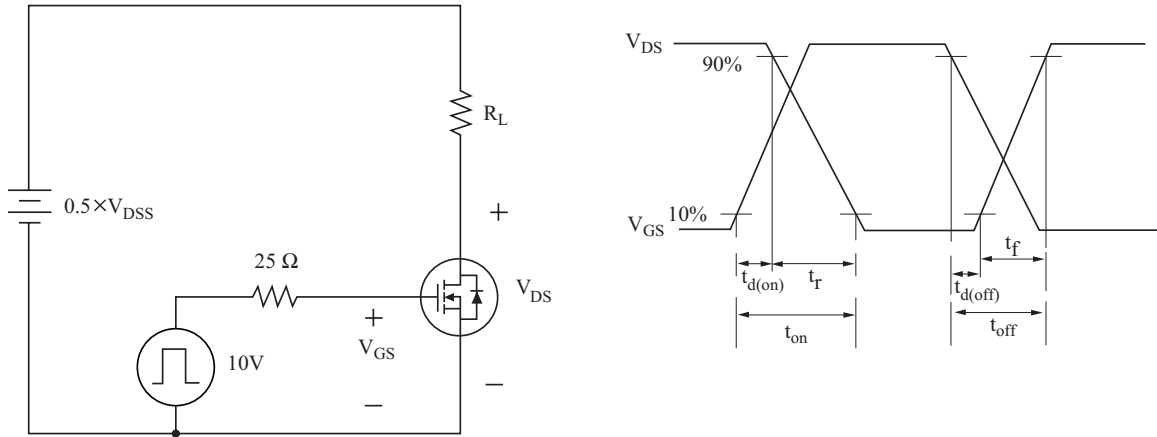
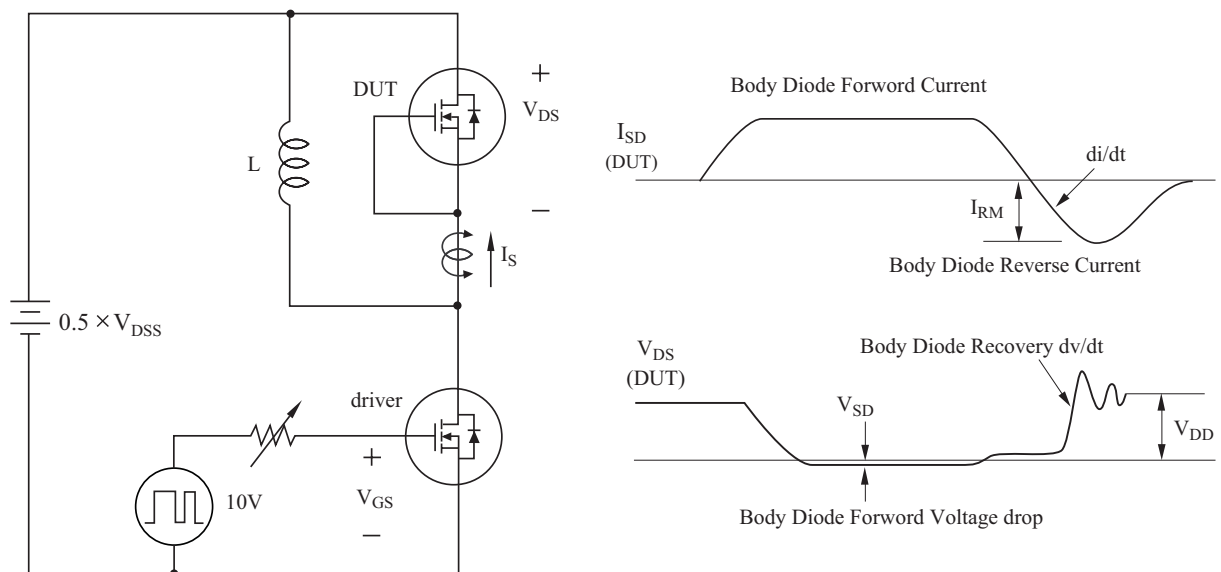

Fig14. Source - Drain Diode Reverse Recovery and  $dv/dt$



# KU3600N10SZ

Fig 15. Recommended Pad Dimension

