

8 HIGH-VOLTAGE HIGH-CURRENT DARLINGTON TRANSISTOR ARRAYS

The KID6508* series are high-voltage, high-current darlington drivers comprised of eight NPN darlington pairs.
All units feature integral clamp diodes for switching inductive loads.
Applications include relay, hammer, lamp and display(LED) drivers.

FEATURES

- Output Current (Single Output) : 500mA Max.
- High Sustaining Voltage Outputs : 50V Min.
- Output Clamp Diodes
- Inputs Compatible With Various Types of Logic.
- PKG Type, AP : DIP-18Pin, DIP-18(1)Pin
- PKG Type, AF : FLP-20Pin
- Suffix U : Qualified to AEC-Q100
ex) KID6508*AF-EL/PU

TYPE	INPUT BASE RESISTOR	DESIGNATION
KID65081AP/AF	External	General Purpose
KID65082AP/AF	10.5k +7V Zenner diode	14 25V P-MOS
KID65083AP/AF	2.7k	TTL, 5V C-MOS
KID65084AP/AF	10.5k	6 15V P-MOS, C-MOS

MAXIMUM RATINGS (Ta=25 , unless otherwise noted)

CHARACTERISTIC	SYMBOL	RATING	UNIT
Output Sustaining Voltage	$V_{CE(SUS)}$	-0.5 50	V
Output Current	I_{OUT}	500	mA/ch
Input Voltage	$V_{IN}(*1)$	-0.5 +30	V
Input Current	$I_{IN}(**2)$	25	mA
Clamp Diode	Reverse Voltage	V_R	50 V
	Forward Current	I_F	500 mA
Power Dissipation	AP	P_D	1.47 W
	AF		0.96 W
Operating Temperature	T_{opr}	-40 85	
Storage Temperature	T_{stg}	-55 150	

*1 Except KID65081AP/AF, **2Only KID65081AP/AF

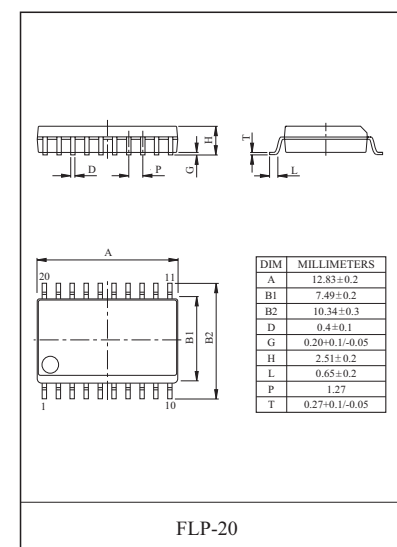
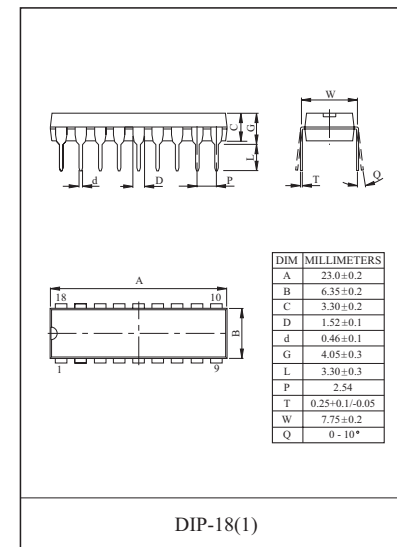
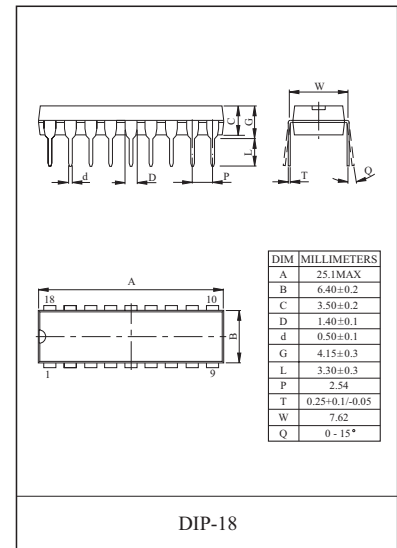

KID65081AP/AF~KID65084AP/AF

PIN CONNECTION (TOP VIEW)

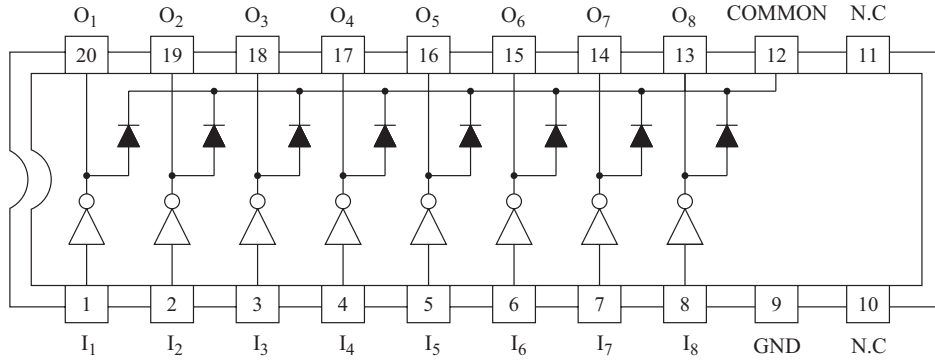

AF-TYPE (FLP-20 PACKAGE)

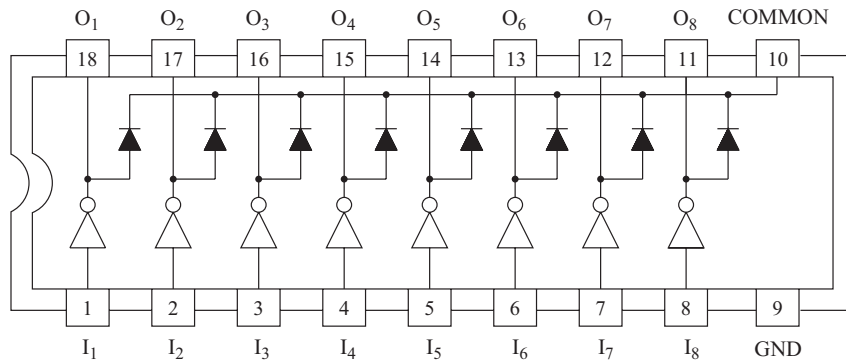

AP-TYPE (DIP-18 PACKAGE)

SCHEMATICS (EACH DRIVER)

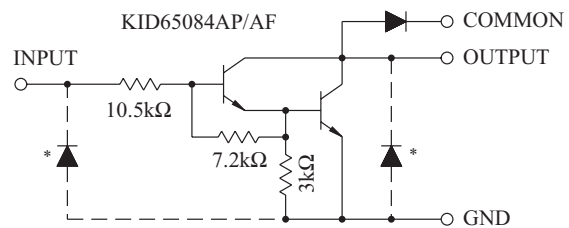
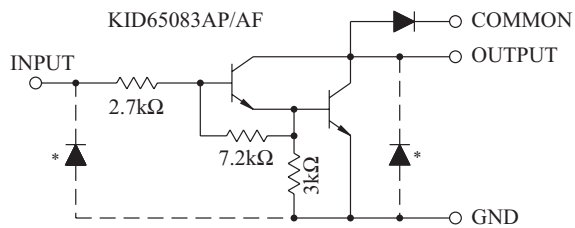
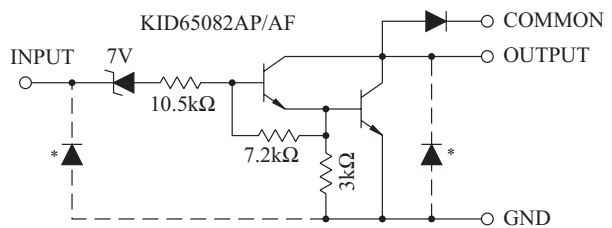
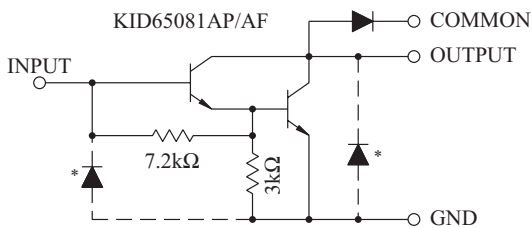

(* : Parasitic Diodes
 (NOTE. The input and output parasitic diodes cannot be used as clamp diodes.))

KID65081AP/AF~KID65084AP/AF

RECOMMENDED OPERATING CONDITIONS (Ta=-40 85)

CHARACTERISTIC		SYMBOL	CONDITION	MIN.	TYP.	MAX.	UNIT
Output Sustaining Voltage		$V_{CE(SUS)}$	-	0	-	50	V
Output Current	AP	I_{OUT}	$T_{PW}=25ms, Duty=8\%, 8 Circuits$	0	-	400	mA/ch
			$T_{PW}=25ms, Duty=25\%, 8 Circuits$	0	-	200	
	AF		$T_{PW}=25ms, Duty=8\%, 8 Circuits$	0	-	350	
			$T_{PW}=25ms, Duty=25\%, 8 Circuits$	0	-	140	
Input Voltage	Except KID65081AP/AF	V_{IN}	-	0	-	30	V
Input Current	Only KID65081AP/AF	I_{IN}	-	-	-	5	mA
Clamp Diode Reverse Voltage		V_R	-	-	-	50	V
Clamp Diode Forward Current		I_F	-	-	-	400	mA
Power Dissipation	AP	P_D	-	-	-	0.52	W
	AF		-	-	-	0.35	

KID65081AP/AF~KID65084AP/AF

ELECTRICAL CHARACTERISTICS (Ta=25 , unless otherwise noted)

CHARACTERISTICS		SYMBOL	TEST CIRCUIT	TEST CONDITION	MIN.	TYP.	MAX.	UNIT
Output Leak Current		I _{CEX}	1	V _{CE} =50V, Ta=25	-	-	50	μA
				V _{CE} =50V, Ta=85	-	-	100	
	KID65082AP/AF			V _{CE} =50V, V _{IN} =6V	-	-	500	
	KID65084AP/AF			V _{CE} =50V, V _{IN} =1V	-	-	500	
Collector-Emitter Saturation Voltage		V _{CE(sat)}	2	I _{OUT} =350mA, I _{IN} =500 μA	-	1.3	1.6	V
				I _{OUT} =200mA, I _{IN} =350 μA	-	1.1	1.3	
				I _{OUT} =100mA, I _{IN} =250 μA	-	0.9	1.1	
Input Current	KID65082AP/AF	I _{IN(ON)}	3	V _{IN} =17V	-	0.82	1.25	mA
	KID65083AP/AF			V _{IN} =3.85V	-	0.93	1.35	
	KID65084AP/AF			V _{IN} =5V	-	0.35	0.5	
				V _{IN} =12V	-	1.0	1.45	
		I _{IN(OFF)}	4	I _{OUT} =500 μA, Ta=85	50	65	-	μA
Input Voltage (Output On)	KID65082AP/AF	V _{IN(ON)}	5	V _{CE} =2V, I _{OUT} =300mA	-	-	13	V
	KID65083AP/AF			V _{CE} =2V, I _{OUT} =200mA	-	-	2.4	
				V _{CE} =2V, I _{OUT} =250mA	-	-	2.7	
				V _{CE} =2V, I _{OUT} =300mA	-	-	3.0	
	KID65084AP/AF			V _{CE} =2V, I _{OUT} =125mA	-	-	5.0	
				V _{CE} =2V, I _{OUT} =200mA	-	-	6.0	
				V _{CE} =2V, I _{OUT} =275mA	-	-	7.0	
				V _{CE} =2V, I _{OUT} =350mA	-	-	8.0	
DC Current Transfer Ratio		h _{FE}	2	V _{CE} =2V, I _{OUT} =350mA	1000	-	-	
Clamp Diode Reverse Current		I _R	6	Ta=25 (*1)	-	-	50	μA
				Ta=85 (*1)	-	-	100	
Clamp Diode Forward Voltage		V _F	7	I _F =350mA	-	-	2.0	V
Input Capacitance		C _{IN}	-	-	-	15	-	pF
Turn-On Delay		t _{ON}	8	R _L =120 , V _{OUT} =50V	-	0.1	-	μs
Turn-Off Delay		t _{OFF}			-	0.2	-	

*1 VR=VR MAX

KID65081AP/AF~KID65084AP/AF

TEST CIRCUIT

1. I_{CEX}

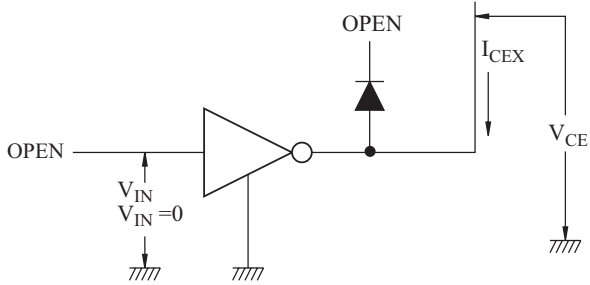

2. $V_{CE(sat)}, h_{FE}$

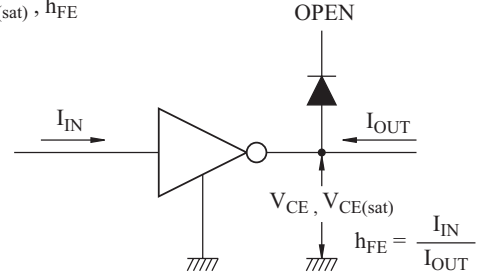

3. $I_{IN(ON)}$

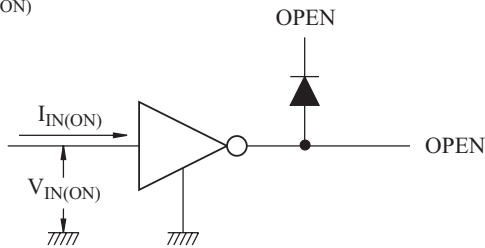

4. $I_{IN(OFF)}$

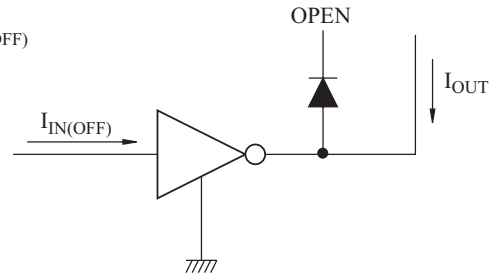

5. $V_{IN(ON)}$

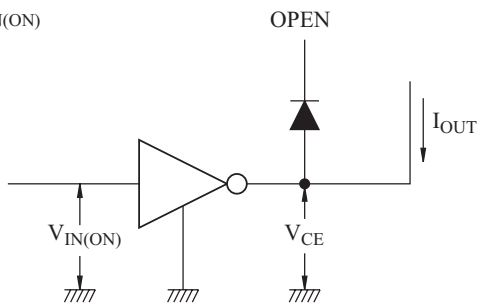

6. I_R

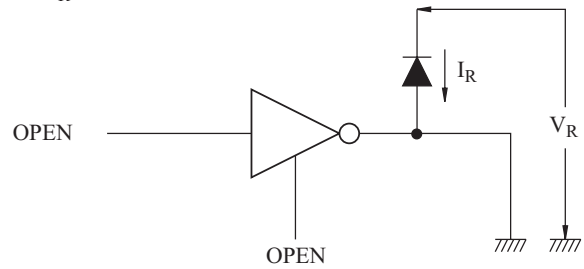

7. V_F

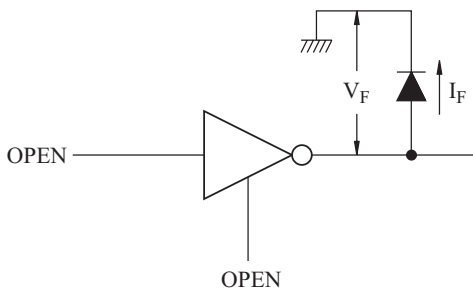

KID65081AP/AF~KID65084AP/AF

8. t_{ON} , t_{OFF}

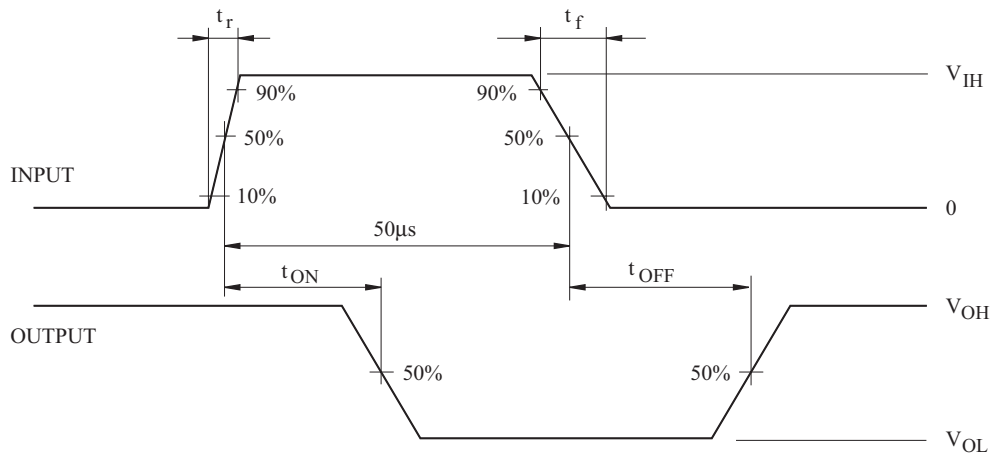
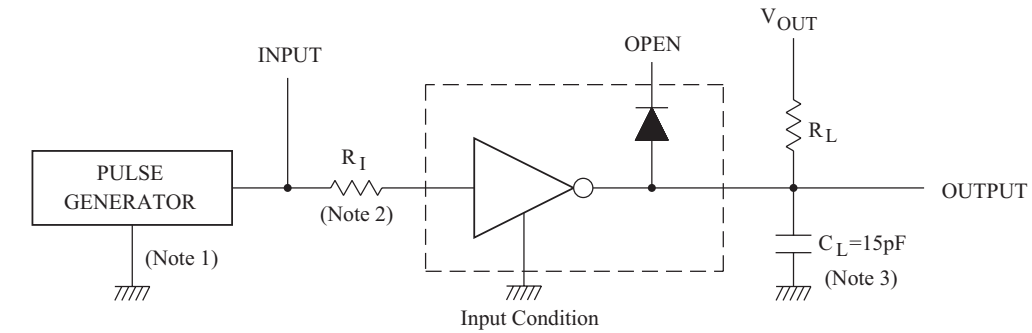

Notes : 1. Pulse Width 50 μ s, Duty Cycle 10%
Output Impedance 50 Ω , t_r 5ns, t_f 10ns

2. See below

Input Conditions

Type Number	R_I	V_{IH}
KID65081AP/AF	2.7k	3V
KID65082AP/AF	0	13V
KID65083AP/AF	0	3V
KID65084AP/AF	0	8V

3. C_L includes probe and Jig capacitance.

KID65081AP/AF~KID65084AP/AF

$I_{IN} - V_{IN}$

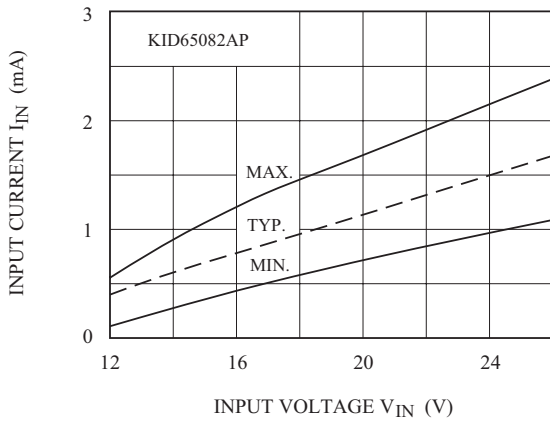

$I_{IN} - V_{IN}$

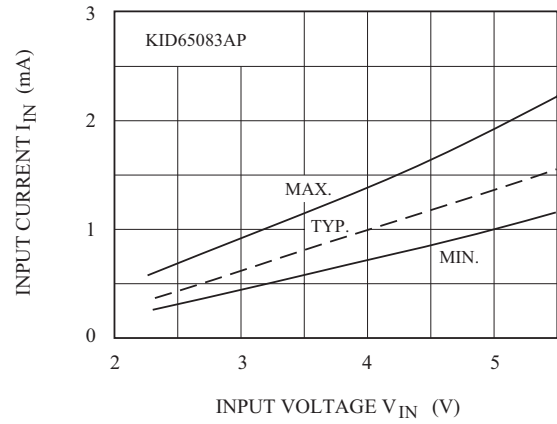

$I_{IN} - V_{IN}$

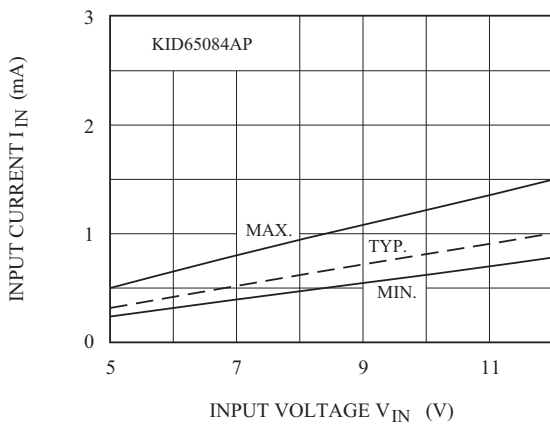

$I_{OUT} - V_{CE(sat)}$

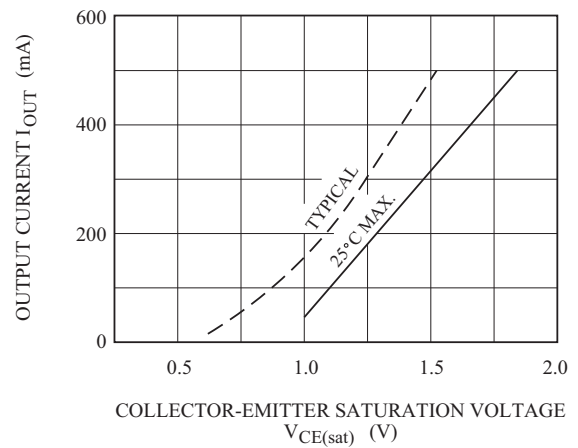

$I_{OUT} - \text{DUTY CYCLE}$

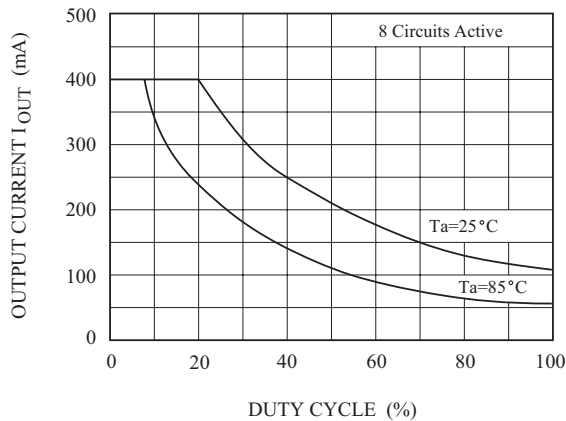

$P_D - T_a$

