

GENERAL PURPOSE APPLICATION.
SWITCHING APPLICATION.

FEATURES

- Low Leakage Current
: $I_{CEX}=50\text{nA}(\text{Max.}), @V_{CE}=30\text{V}, V_{EB}=3\text{V}.$
- Low Saturation Voltage
: $V_{CE(\text{sat})}=0.3\text{V}(\text{Max.}) @I_C=50\text{mA}, I_B=5\text{mA}.$
- Complementary to KN3906.

MAXIMUM RATING (Ta=25°C)

CHARACTERISTIC	SYMBOL	RATING	UNIT
Collector-Base Voltage	V_{CBO}	60	V
Collector-Emitter Voltage	V_{CEO}	40	V
Emitter-Base Voltage	V_{EBO}	6	V
Collector Current	I_C	200	mA
Base Current	I_B	50	mA
Collector Power Dissipation	P_C	625	mW
Junction Temperature	T_j	150	°C
Storage Temperature Range	T_{stg}	-55~ 150	°C

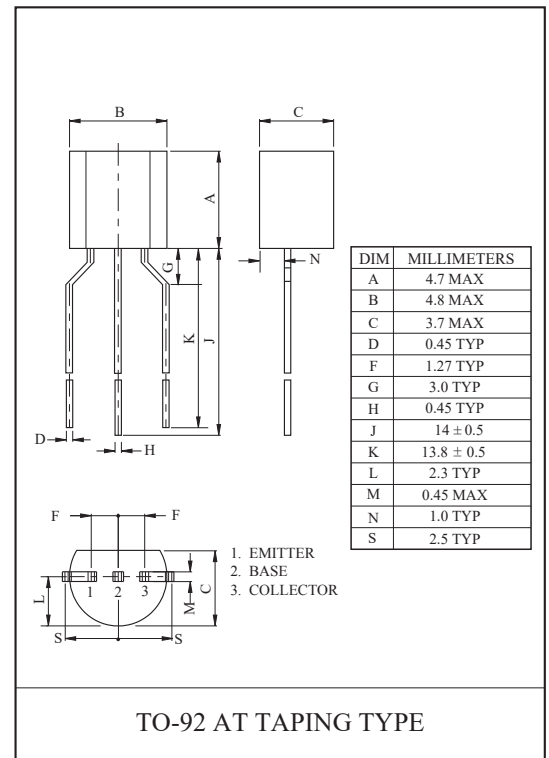
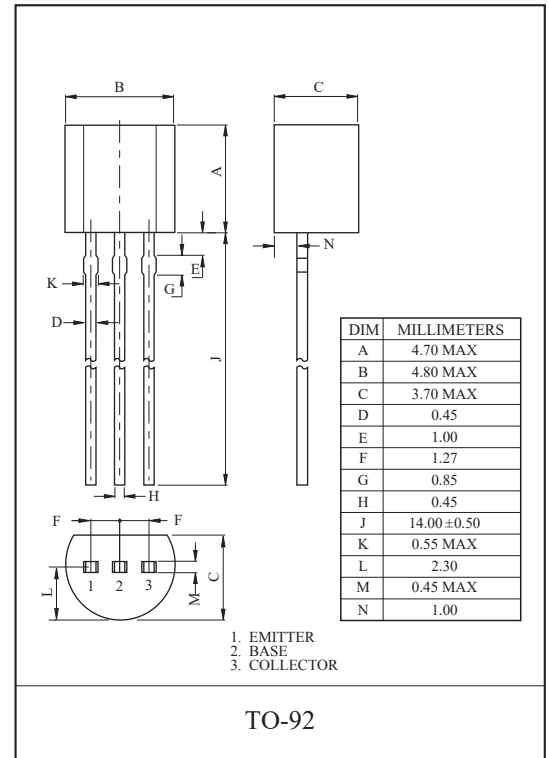

KN3904

ELECTRICAL CHARACTERISTICS (Ta=25°C)

CHARACTERISTIC	SYMBOL	TEST CONDITION	MIN.	TYP.	MAX.	UNIT
Collector Cut-off Current	I_{CEX}	$V_{CE}=30V, V_{EB}=3V$	-	-	50	nA
Collector-Base Breakdown Voltage	$V_{(BR)CBO}$	$I_C=10\mu A, I_E=0$	60	-	-	V
Collector-Emitter Breakdown Voltage *	$V_{(BR)CEO}$	$I_C=1mA, I_B=0$	40	-	-	V
Emitter-Base Breakdown Voltage	$V_{(BR)EBO}$	$I_E=10\mu A, I_C=0$	6	-	-	V
DC Current Gain *	$h_{FE(1)}$	$V_{CE}=1V, I_C=0.1mA$	40	-	-	
	$h_{FE(2)}$	$V_{CE}=1V, I_C=1mA$	70	-	-	
	$h_{FE(3)}$	$V_{CE}=1V, I_C=10mA$	100	-	300	
	$h_{FE(4)}$	$V_{CE}=1V, I_C=50mA$	60	-	-	
	$h_{FE(5)}$	$V_{CE}=1V, I_C=100mA$	30	-	-	
Collector-Emitter Saturation Voltage *	$V_{CE(sat)1}$	$I_C=10mA, I_B=1mA$	-	-	0.2	V
	$V_{CE(sat)2}$	$I_C=50mA, I_B=5mA$	-	-	0.3	
Base-Emitter Saturation Voltage *	$V_{BE(sat)1}$	$I_C=10mA, I_B=1mA$	0.65	-	0.85	V
	$V_{BE(sat)2}$	$I_C=50mA, I_B=5mA$	-	-	0.95	
Transition Frequency	f_T	$V_{CE}=20V, I_C=10mA, f=100MHz$	-	300	-	MHz
Collector Output Capacitance	C_{ob}	$V_{CB}=5V, I_E=0, f=1MHz$	-	-	4.0	pF

* Pulse Test : Pulse Width $\leq 300\mu S$, Duty Cycle $\leq 2\%$.

KN3904

$h_{FE} - I_C$

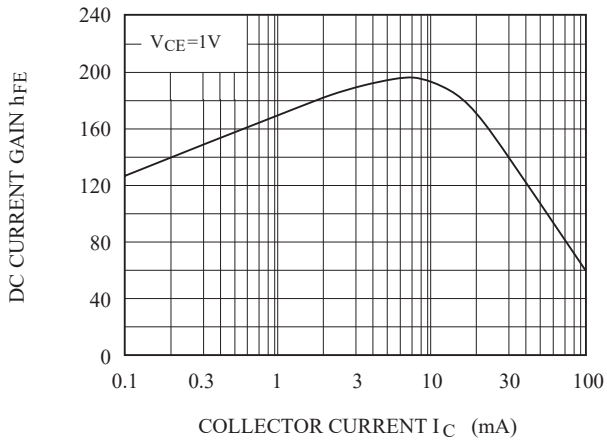

$C_{ob} - V_{CB}$

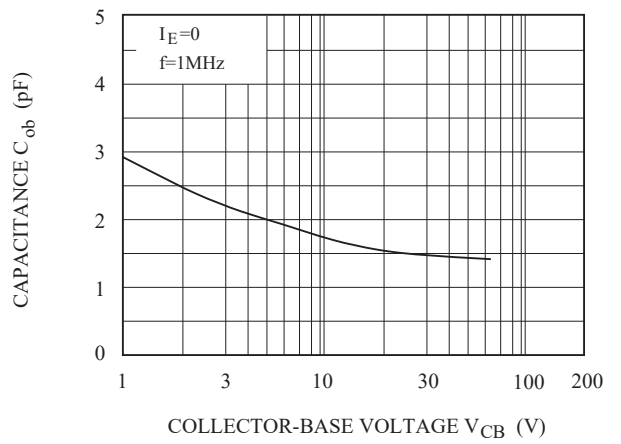

$V_{BE(sat)}, V_{CE(sat)} - I_C$

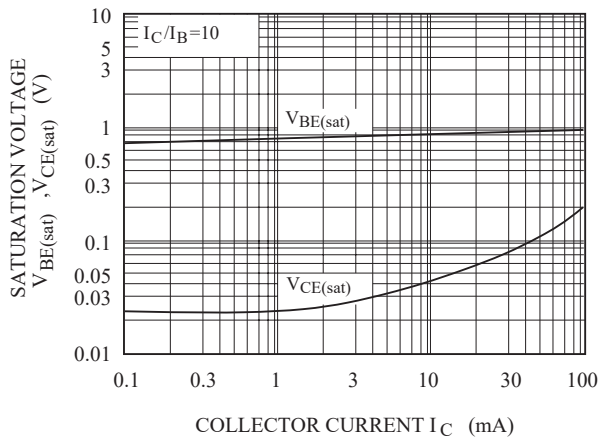

$P_c - T_a$

