

1200V, 40A Field Stop Trench IGBTs KGF40N120KDA

KEC Field Stop Trench IGBTs offer low switching losses, high energy efficiency and short circuit ruggedness. It is designed for applications such as motor control, uninterrupted power supplies(UPS), general inverters.

FEATURES

- High Speed Switching
- High System Efficiency
- Short Circuit Withstand Times > 10μs
- Extremely Enhanced Avalanche Capability

APPLICATIONS

- Welder
- Uninterrupted Power Supplies(UPS)
- Motor Driver
- General Inverters
- Solar Inverter

ORDERING INFORMATION

PART NUMBER	QTY per Tube	QTY per Carton Box
KGF40N120KDA-U/H	30 pcs	1,800 pcs
KGF40N120KDA-U/HE	30 pcs	1,800 pcs

*Suffix E : TO-247(E) Package

PACKAGE DIMENSION(TO-247)

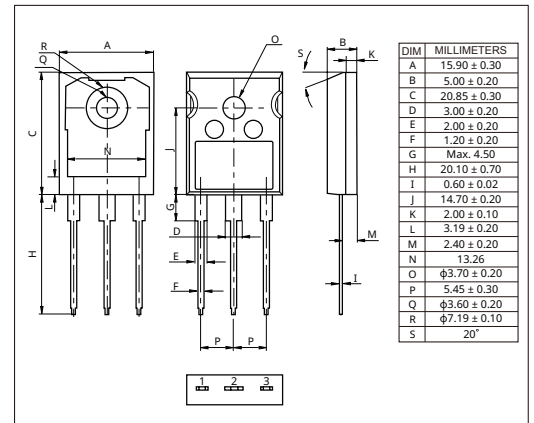

PACKAGE DIMENSION(TO-247(E))

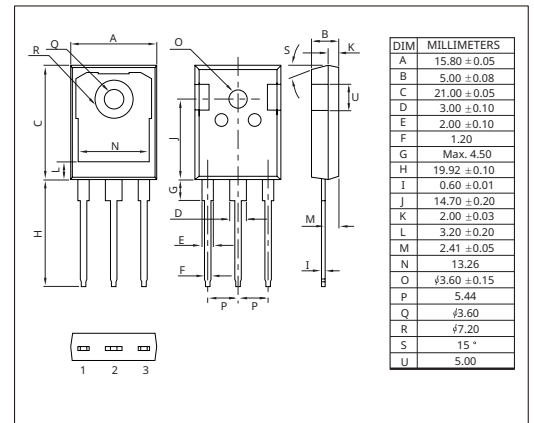

PIN CONFIGURATION

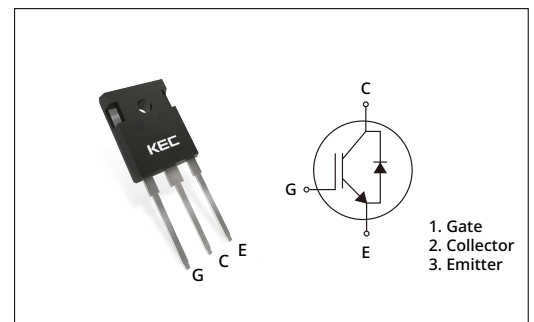

MARKING CODE

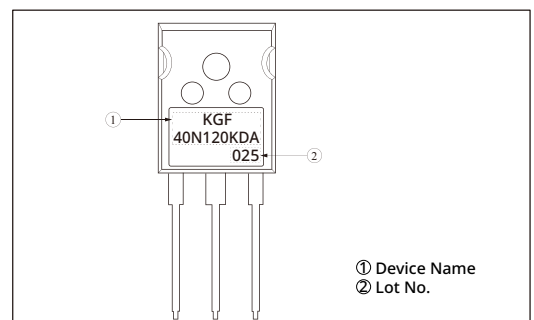

PRODUCT DATASHEET

FS Trench - IGBT - KGF40N120KDA

MAXIMUM RATING ($T_a=25^{\circ}\text{C}$, unless otherwise specified)

CHARACTERISTICS		SYMBOL	VALUES	UNIT	
Collector-Emitter Voltage		V_{CES}	1200	V	
Gate-Emitter Voltage		V_{GES}	± 20	V	
Collector Current	@ $T_c=25^{\circ}\text{C}$	I_C	80	A	
	@ $T_c=100^{\circ}\text{C}$		40		
Pulsed Collector Current		I_{CM}^*	120	A	
DIODE Continuous Forward Current		@ $T_c=100^{\circ}\text{C}$	I_F	40	A
DIODE Maximum Forward Current		I_{FM}	160	A	
Maximum Power Dissipation	@ $T_c=25^{\circ}\text{C}$	P_D	357	W	
	@ $T_c=100^{\circ}\text{C}$		140	W	
Maximum Junction Temperature		T_J	150	$^{\circ}\text{C}$	
Storage Temperature Range		T_{stg}	-55 ~ +150	$^{\circ}\text{C}$	

*Repetitive rating : Pulse width limited by max. junction temperature

THERMAL CHARACTERISTICS

CHARACTERISTICS	SYMBOL	MAX	UNIT
Thermal Resistance, Junction to Case (IGBT)	R_{thJC}	0.35	$^{\circ}\text{C}/\text{W}$
Thermal Resistance, Junction to Case (DIODE)		0.56	$^{\circ}\text{C}/\text{W}$
Thermal Resistance, Junction to Ambient	R_{thJA}	40	$^{\circ}\text{C}/\text{W}$

PRODUCT DATASHEET
FS Trench - IGBT - KGF40N120KDA

ELECTRICAL CHARACTERISTICS OF IGBT ($T_a = 25^\circ\text{C}$, unless otherwise specified)

CHARACTERISTICS	SYMBOL	CONDITIONS	VALUES			UNIT
			MIN.	TYP.	MAX.	
Static						
Collector-Emitter Breakdown Voltage	BV_{CES}	$V_{GE}=0V, I_C=1mA$	1200	-	-	V
Collector Cut-off Current	I_{CES}	$V_{GE}=0V, V_{CE}=1200V$	-	-	1.0	mA
Gate Leakage Current	I_{GES}	$V_{CE}=0V, V_{GE}=\pm 20V$	-	-	± 100	nA
Gate Threshold Voltage	$V_{GE(th)}$	$V_{GE}=V_{CE}, I_C=40mA$	4.5	6.0	7.5	V
Collector-Emitter Saturation Voltage	$V_{CE(sat)}$	$V_{GE}=15V, I_C=40A$	-	1.9	2.25	V
		$V_{GE}=15V, I_C=40A, T_C=125^\circ\text{C}$	-	2.2	-	V
		$V_{GE}=15V, I_C=80A$	-	2.5	-	V
Dynamic						
Total Gate Charge	Q_g	$V_{CC}=600V, I_C=40A, V_{GE}=15V$	-	230	350	nC
Gate-Emitter Charge	Q_{ge}		-	30	-	nC
Gate-Collector Charge	Q_{gc}		-	110	-	nC
Input Capacitance	C_{ies}	$V_{CE}=30V, V_{GE}=0V, f=1MHz$	-	4800	-	pF
Output Capacitance	C_{oes}		-	195	-	pF
Reverse Transfer Capacitance	C_{res}		-	135	-	pF
Switching						
Turn-on Delay Time	$t_{d(on)}$	$V_{CC}=600V, I_C=40A, V_{GE}=15V,$ $R_G=10\Omega$ Inductive Load, $T_C=25^\circ\text{C}$	-	60	-	ns
Rise Time	t_r		-	45	-	ns
Turn-off Delay Time	$t_{d(off)}$		-	310	-	ns
Fall Time	t_f		-	70	-	ns
Turn-on Switching Loss	E_{on}		-	3.5	5.2	mJ
Turn-off Switching Loss	E_{off}		-	1.9	2.8	mJ
Total Switching Loss	E_{ts}		-	5.4	8.0	mJ
Turn-on Delay Time	$t_{d(on)}$	$V_{CC}=600V, I_C=40A, V_{GE}=15V,$ $R_G=10\Omega$ Inductive Load, $T_C=125^\circ\text{C}$	-	60	-	ns
Rise Time	t_r		-	50	-	ns
Turn-off Delay Time	$t_{d(off)}$		-	350	-	ns
Fall Time	t_f		-	175	-	ns
Turn-on Switching Loss	E_{on}		-	4.3	6.4	mJ
Turn-off Switching Loss	E_{off}		-	3.0	4.5	mJ
Total Switching Loss	E_{ts}		-	7.3	10.9	mJ

PRODUCT DATASHEET
FS Trench - IGBT - KGF40N120KDA

ELECTRICAL CHARACTERISTICS OF DIODE

CHARACTERISTICS	SYMBOL	CONDITIONS		VALUES			UNIT
				MIN.	TYP.	MAX.	
Forward Voltage	V_F	$I_F=40A$	$T_C=25^{\circ}C$	-	2.6	2.9	V
			$T_C=125^{\circ}C$	-	2.7	-	
Reverse Recovery Time	t_{rr}		$T_C=25^{\circ}C$	-	330	-	ns
			$T_C=125^{\circ}C$	-	540	-	
Peak Reverse Recovery Current	I_{RRM}	$V_{CC}=600V$ $I_F=40A$ $dI_F/dt=200A/\mu s$	$T_C=25^{\circ}C$	-	16	-	A
			$T_C=125^{\circ}C$	-	19	-	
Reverse Recovery Charge	Q_{rr}		$T_C=25^{\circ}C$	-	2	-	μC
			$T_C=125^{\circ}C$	-	3.9	-	

PRODUCT DATASHEET

FS Trench - IGBT - KGF40N120KDA

Fig 1. Saturation Voltage Characteristics

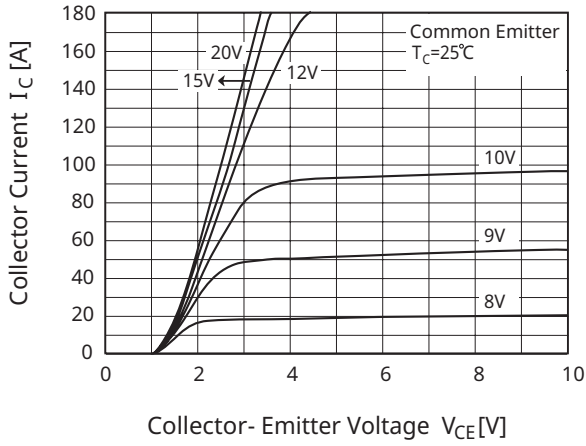

Fig 2. Saturation Voltage Characteristics

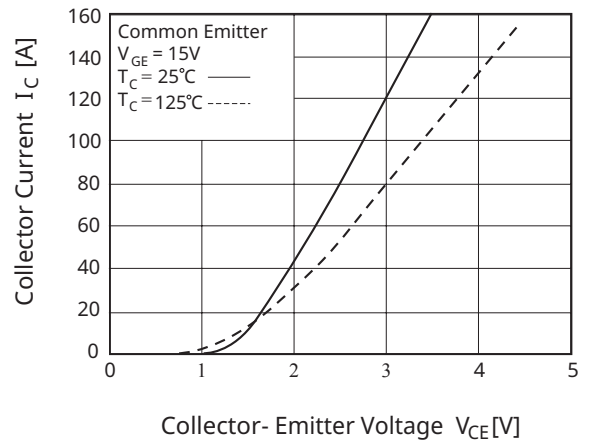

Fig 3. Saturation Voltage vs. Case Temperature

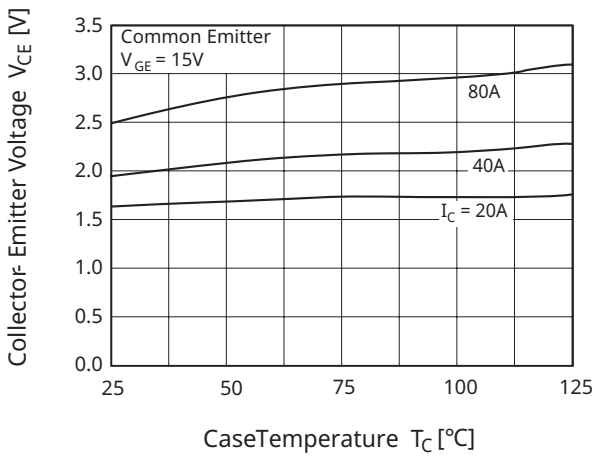

Fig 4. Saturation Voltage vs. V_{GE}

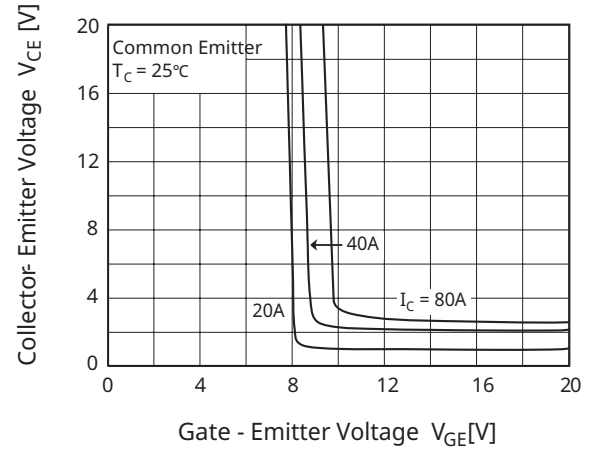

Fig 5. Saturation Voltage vs. V_{GE}

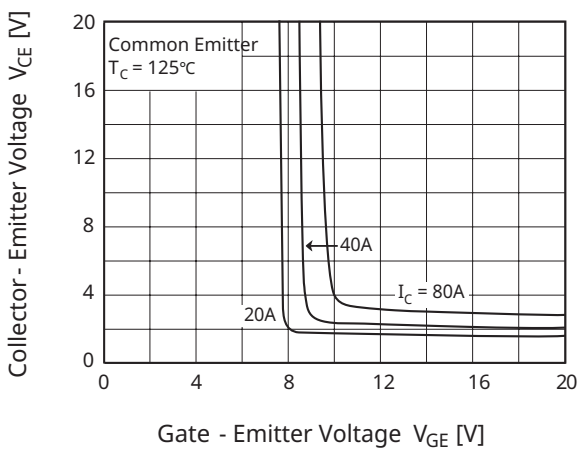
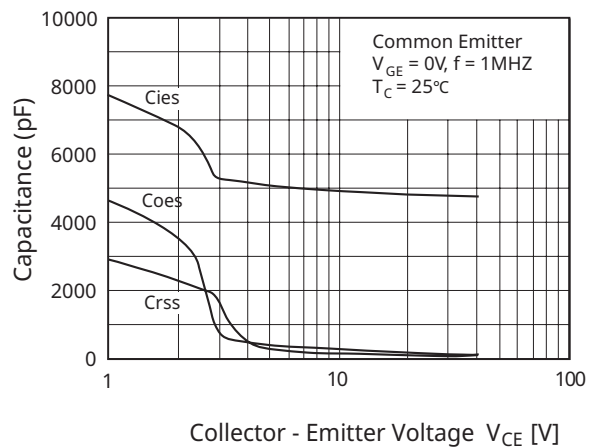

Fig 6. Capacitance Characteristics



PRODUCT DATASHEET

FS Trench - IGBT - KGF40N120KDA

Fig 7. Turn-On Characteristics vs. Gate Resistance

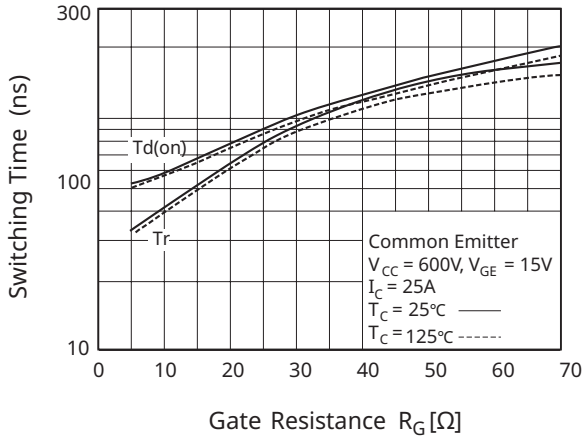

Fig 8. Turn-Off Characteristics vs. Gate Resistance

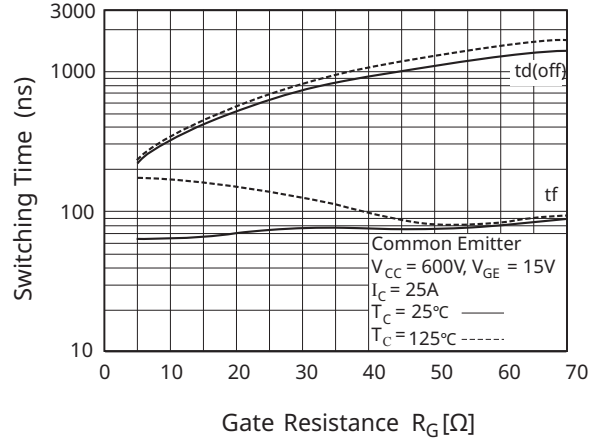

Fig 9. Switching Loss vs. Gate Resistance

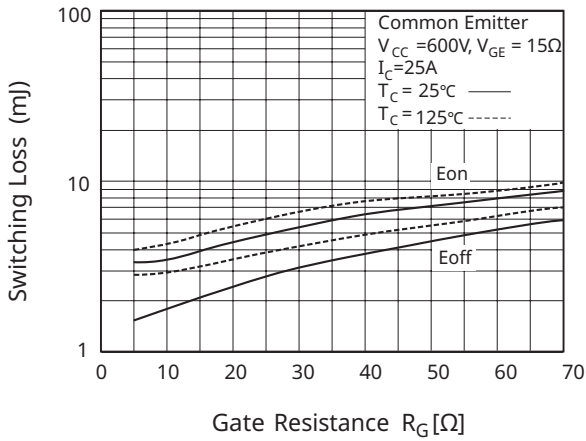

Fig 10. Turn-On Characteristics vs. Collector Current

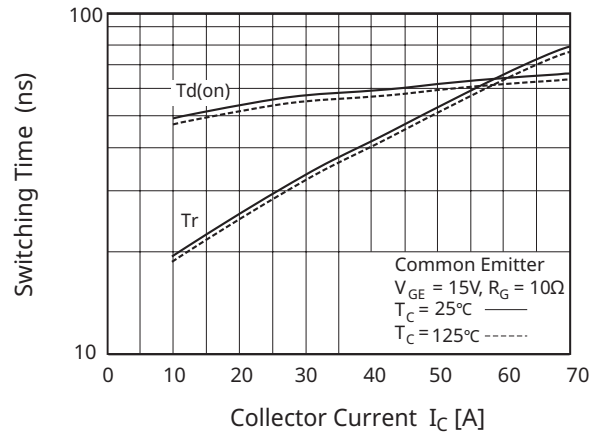

Fig 11. Turn-Off Characteristics vs. Collector Current

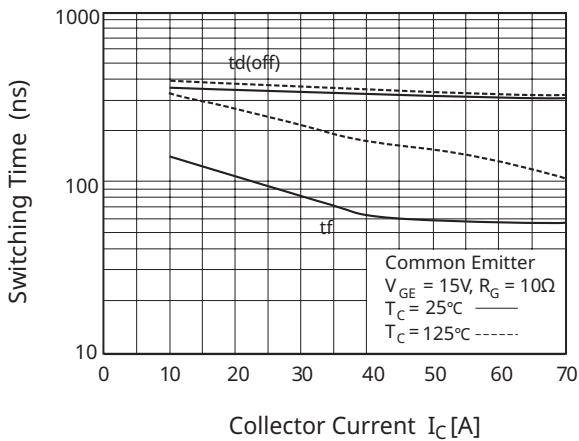
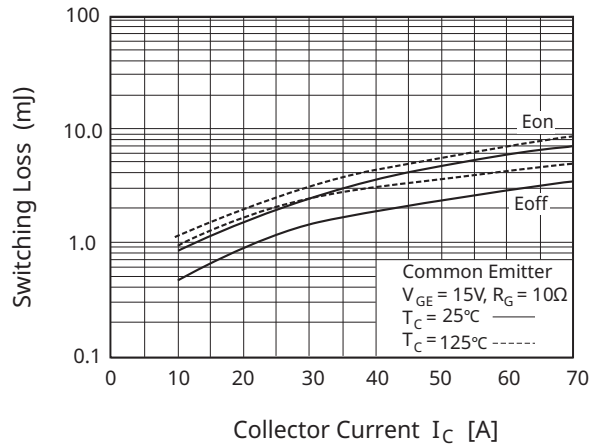

Fig 12. Switching Loss vs. Collector Current



PRODUCT DATASHEET

FS Trench - IGBT - KGF40N120KDA

Fig 13. Gate Charge Characteristics

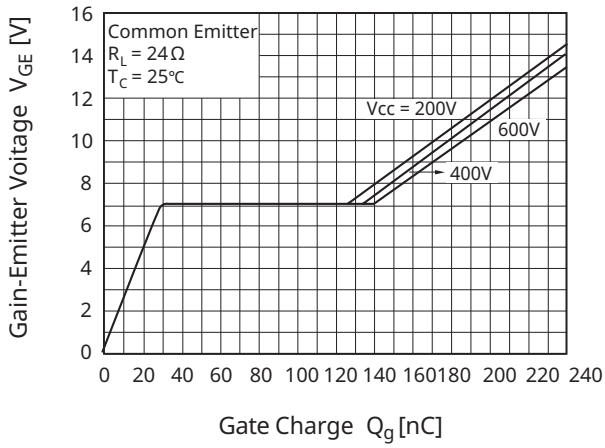

Fig 14. SOA Characteristics

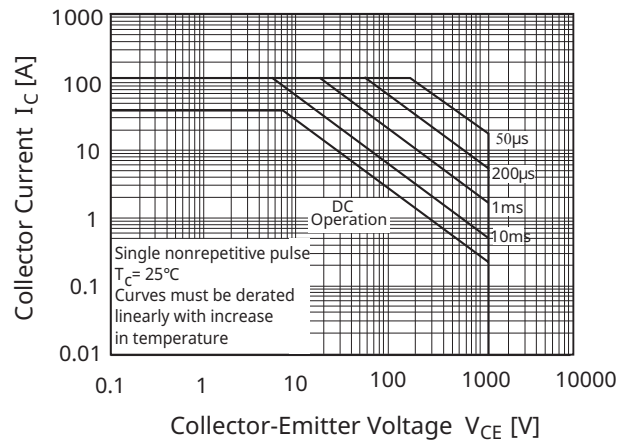

Fig 15. Turn-Off SOA

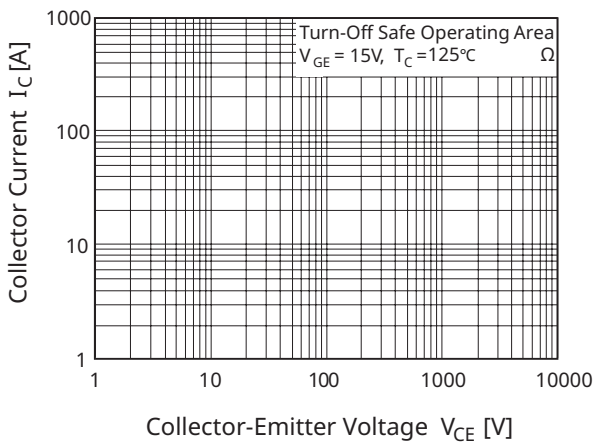
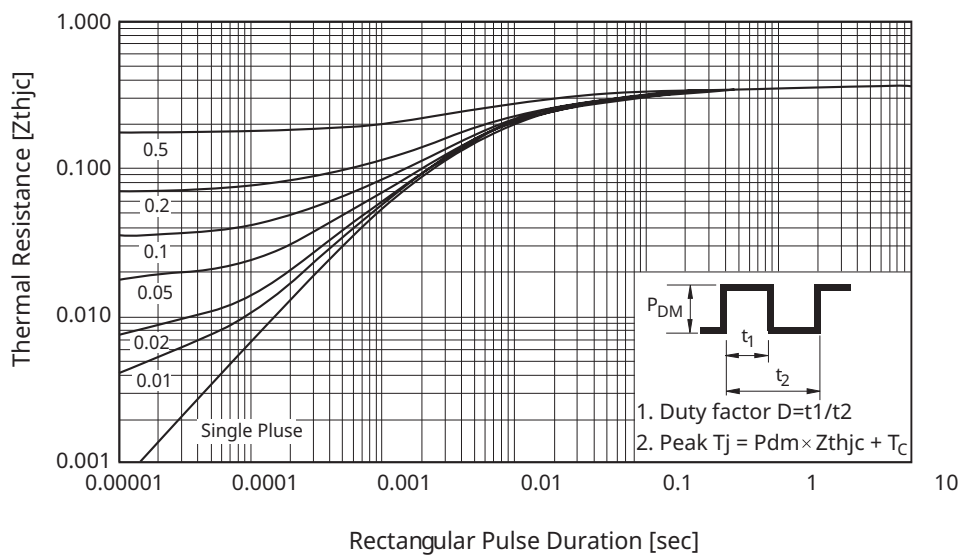

Fig 16. Transient Thermal Impedance of IGBT



PRODUCT DATASHEET

FS Trench - IGBT - KGF40N120KDA

Fig 17. Forward Characteristics

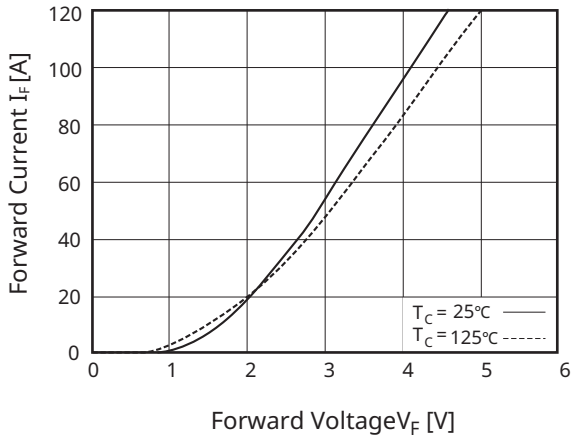

Fig 18. Reverse Recovery Time

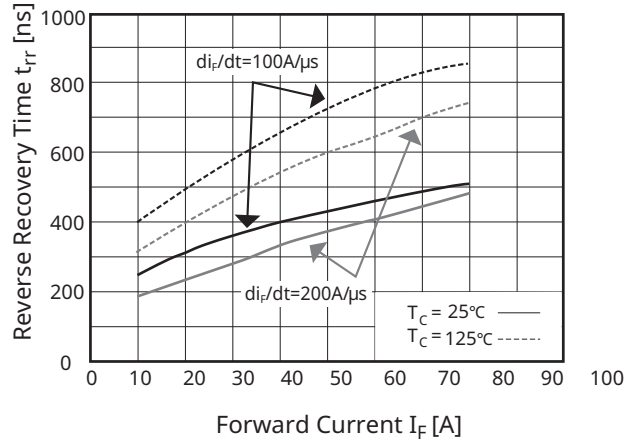

Fig 19. Reverse Recovery Current

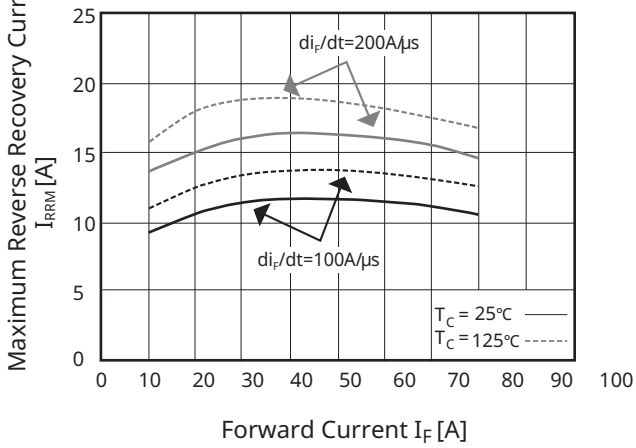
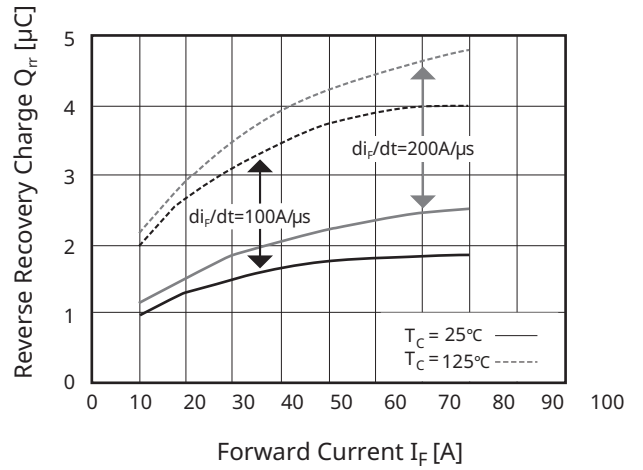

Fig 20. Reverse Recovery Charge



PRODUCT DATASHEET

FS Trench - IGBT - KGF40N120KDA

Condition

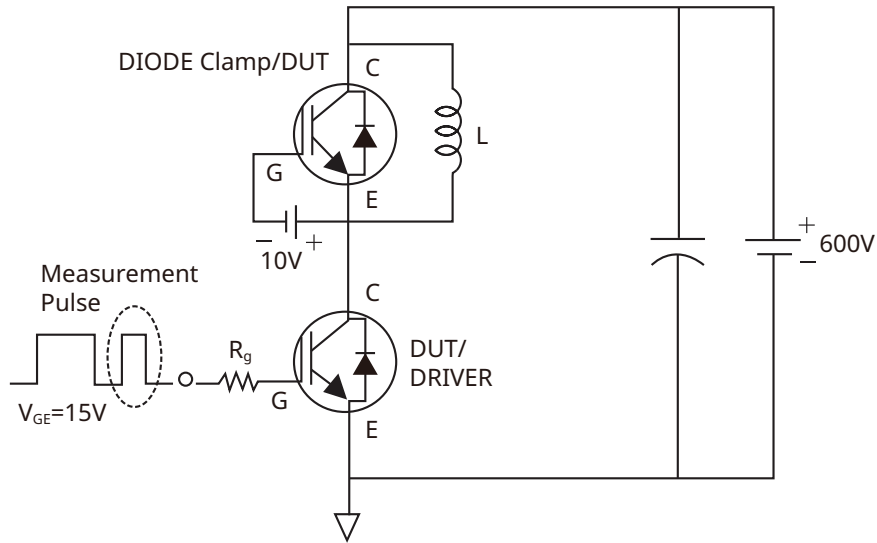

Figure a. Switching Test Circuit

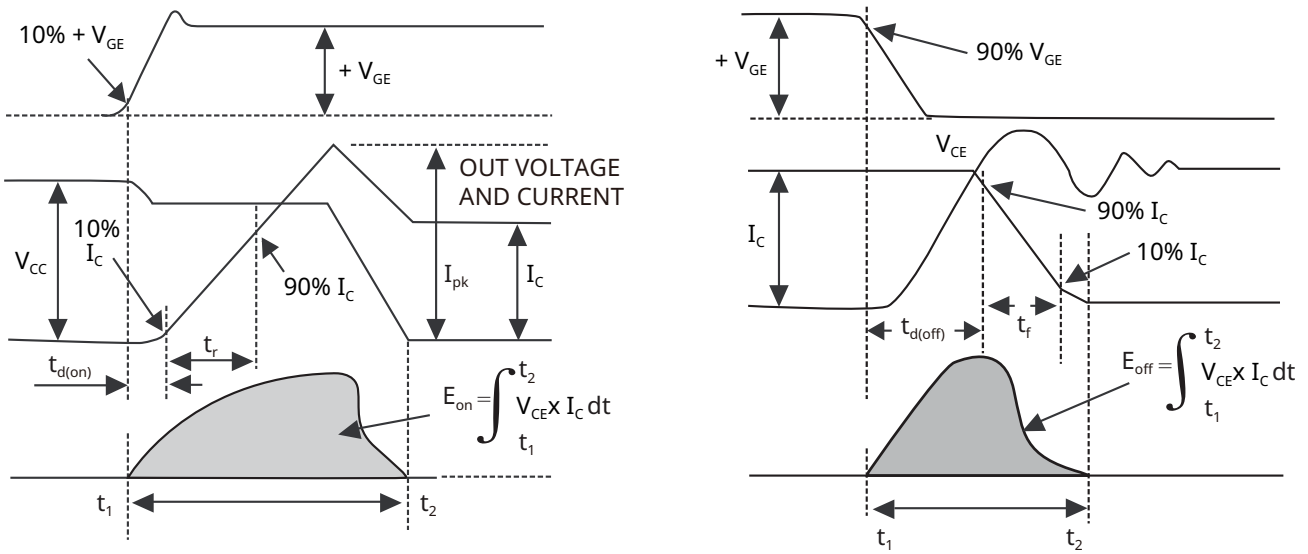

Figure b. Definition Switching Time & Losses

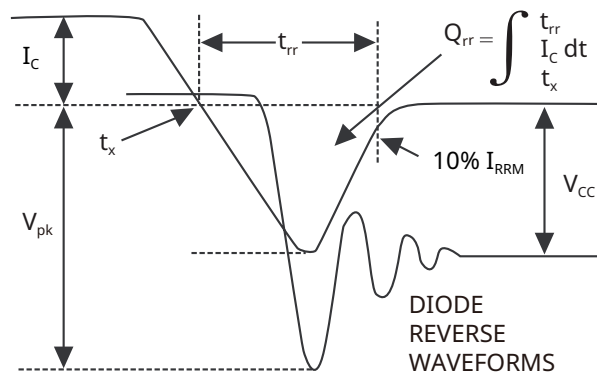

Figure c. Definition of DIODE Switching Characteristics

PRECAUTION ON USING KEC PRODUCTS

1. The products described in this data are intended to be used in general-purpose electronic equipment. (Office equipment, telecommunication equipment, measuring equipment, home appliances)
2. When you intend to use these products with equipment or device which require an extremely high of reliability and special applications (such as automobile, air travel aerospace, transportation equipment, life support, system and safety devices) in which special quality and reliability and the failure or malfunction of products may directly jeopardize or harm the human body or damage to property and any application other than the standard application intended, please be sure to consult with our sales representative in advance.
3. On designing your application, please use product within the ranges guaranteed by KEC for maximum rating, operating supply voltage range, heat radiation characteristics and other characteristics. User shall be responsible for failure or damage when used beyond the guaranteed ranges.
4. The technical information described in this data is limited to showing representative characteristics and applied circuit examples of the products and it does not constitute the warranting of industrial property, the granting of relative rights, or the granting of any license.
5. What are described in the data may be changed without any prior notice to reflect new technical development. Please confirm that you have received the latest product standards or specification before final design, purchase or use.
6. Although KEC is continuously working to improve product reliability and quality, semiconductors can break down and malfunction due to various factors. Therefore, in order to prevent personal injury or fire arising from failure, please take safety measures such as complying with the derating characteristics, implementing redundant and fire prevention designs, and utilizing backups and fail-safe procedures. KEC shall have no responsibility for any damages arising out of the use of our Products beyond the rating specified by KEC.

**For additional information,
please contact your local Sales Representative.**

SOUTH KOREA (Headquarters)
KEC CORPORATION
PHONE : +82-2-2025-5000
sales@kec.co.kr

JAPAN
KEC JAPAN CO.,LTD.
PHONE : +81-03-5475-2691
kec_jp@kec.co.kr

SINGAPORE
KEC SINGAPORE PTE., LTD.
PHONE : +65-6748-7372(#102)
kec_sg@kec.co.kr

THAILAND
**KEC THAILAND BANGKOK
OFFICE**
PHONE : +66-2-576-1484~5
kec_th@kec.co.kr

CHINA
KEC SHANGHAI CO.,LTD.
PHONE : +86-21-5490-2277
kec_sh@kec.co.kr

KEC SHENZHEN OFFICE
PHONE : +86-755-8830-8899
kec_hk@kec.co.kr

KEC TIANJIN OFFICE
PHONE : +86-21-5490-2277
kec_sh@kec.co.kr

HONG KONG
KEC HK CORP. LTD
PHONE : +852-2249-3734
kec_hk@kec.co.kr

TAIWAN
KEC TAIWAN CO.,LTD.
PHONE : +886-2-2515-8359
kec_twn@kec.co.kr

U.S.A
KEC AMERICA CORP.
PHONE : +1-714-259-0662
kec_a@kec.co.kr

