

Schottky Barrier Diode

KDR720EL2A

LOW POWER RECTIFICATION
AND HIGH SPEED SWITCHING

FEATURES

- Low Forward Voltage
- High Reliability
- Small Package

APPLICATION

- Low voltage rectification
- High efficiency DC-to-DC conversion
- Switch mode power supply
- Inverse polarity protection
- Low power consumption applications

ORDERING INFORMATION

PART NUMBER	QTY PER REEL	REEL SIZE
KDR720EL2A-RTL/H	10,000 pcs	7 inch

PACKAGE DIMENSION (ELP-2A)

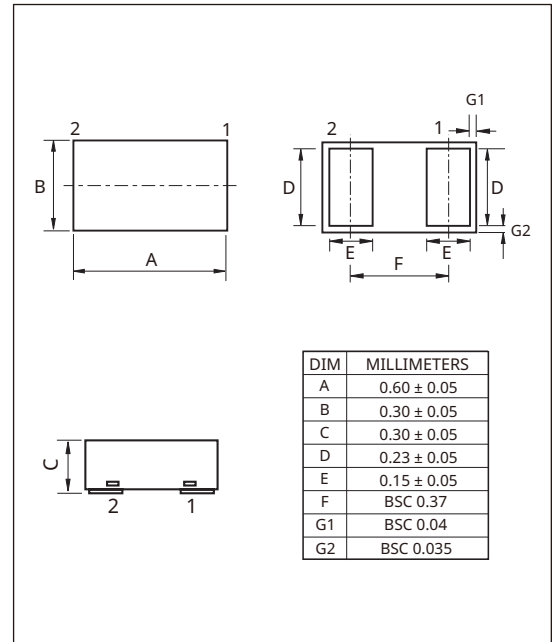

PIN CONFIGURATION

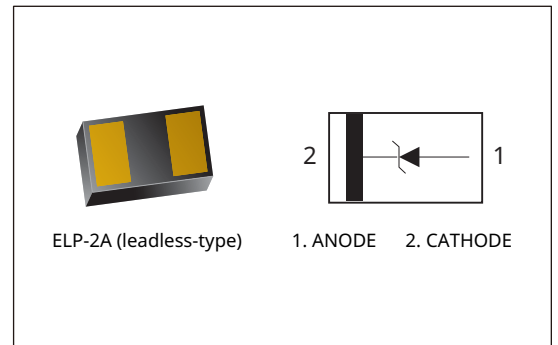

MARKING CODE

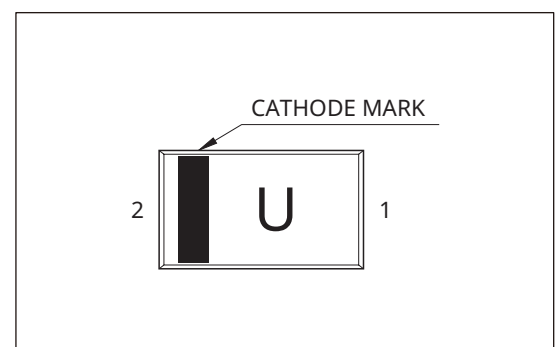

PRODUCT DATASHEET

Schottky Barrier Diode - KDR720EL2A

MAXIMUM RATING (Ta=25°C)

CHARACTERISTIC	SYMBOL	RATING	UNIT
Reverse Voltage	V_R	30	V
Average Forward Current	I_O	200	mA
Surge Current(1ms)	I_{FSM}	0.5	A
Junction Temperature	T_J	-55 ~ 150	°C
Storage Temperature Range	T_{STG}	-55 ~ 150	°C

ELECTRICAL CHARACTERISTICS (Ta=25°C)

CHARACTERISTIC	SYMBOL	TEST CONDITION	MIN.	TYP.	MAX.	UNIT
Forward Voltage	V_F	$I_F = 10\text{mA}$	-	-	0.37	V
Reverse Current	I_R	$V_R = 10\text{V}$	-	-	7	μA

PRODUCT DATASHEET

Schottky Barrier Diode - KDR720EL2A

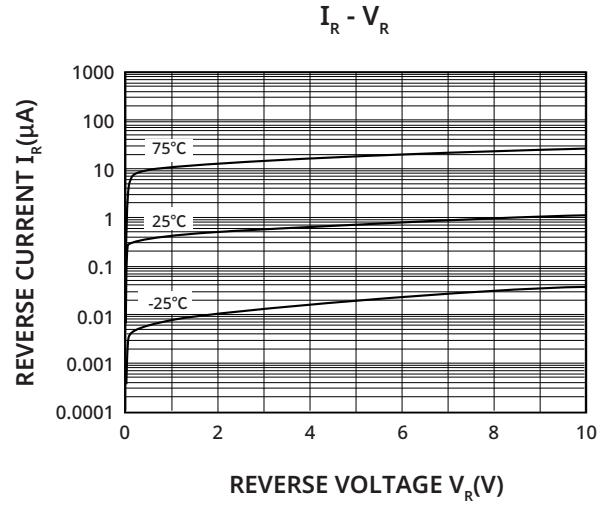
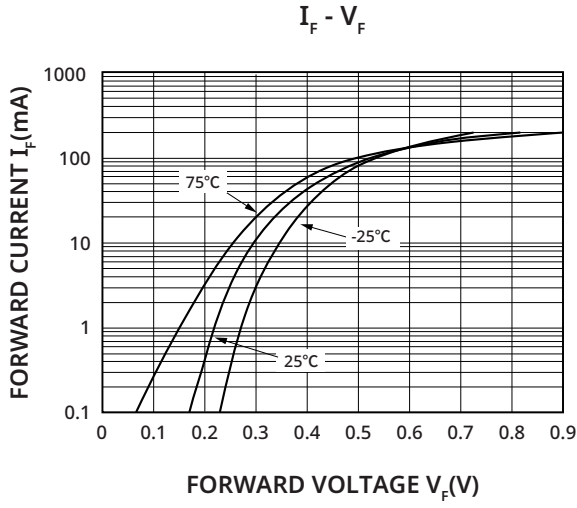

PRODUCT DATASHEET
Schottky Barrier Diode - KDR720EL2A

PACKAGE INFORMATION (ELP-2A)

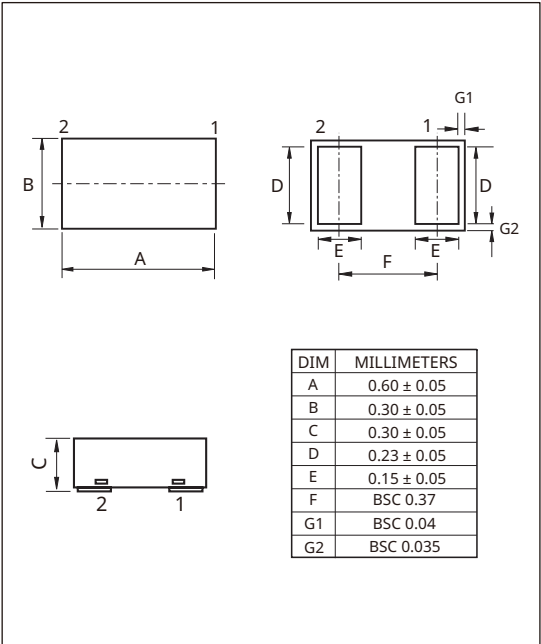

RECOMMENDED PAD DIMENSION (ELP-2A)

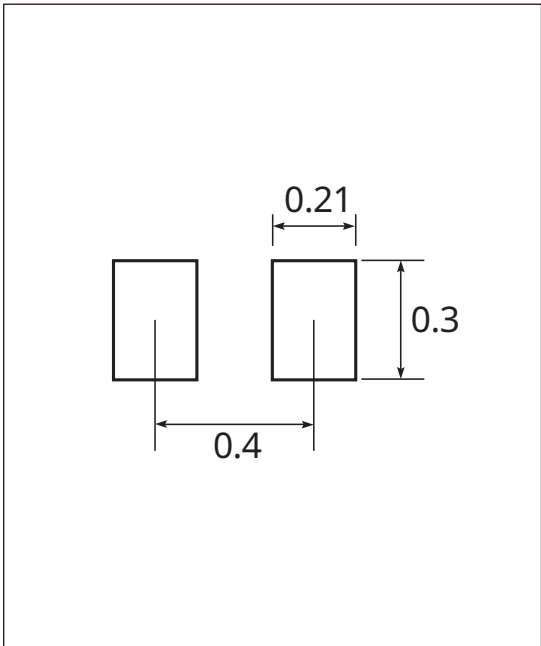

PRECAUTION ON USING KEC PRODUCTS

1. The products described in this data are intended to be used in general-purpose electronic equipment. (Office equipment, telecommunication equipment, measuring equipment, home appliances)
2. When you intend to use these products with equipment or device which require an extremely high of reliability and special applications (such as automobile, air travel aerospace, transportation equipment, life support, system and safety devices) in which special quality and reliability and the failure or malfunction of products may directly jeopardize or harm the human body or damage to property and any application other than the standard application intended, please be sure to consult with our sales representative in advance.
3. On designing your application, please use product within the ranges guaranteed by KEC for maximum rating, operating supply voltage range, heat radiation characteristics and other characteristics. User shall be responsible for failure or damage when used beyond the guaranteed ranges.
4. The technical information described in this data is limited to showing representative characteristics and applied circuit examples of the products and it does not constitute the warranting of industrial property, the granting of relative rights, or the granting of any license.
5. What are described in the data may be changed without any prior notice to reflect new technical development. Please confirm that you have received the latest product standards or specification before final design, purchase or use.
6. Although KEC is continuously working to improve product reliability and quality, semiconductors can break down and malfunction due to various factors. Therefore, in order to prevent personal injury or fire arising from failure, please take safety measures such as complying with the derating characteristics, implementing redundant and fire prevention designs, and utilizing backups and fail-safe procedures. KEC shall have no responsibility for any damages arising out of the use of our Products beyond the rating specified by KEC.

For additional information,
please contact your local Sales Representative.

SOUTH KOREA (Headquarters)
KEC CORPORATION
PHONE : +82-2-2025-5000
sales@kec.co.kr

JAPAN
KEC JAPAN CO.,LTD.
PHONE : +81-03-5475-2691
kec_jp@kec.co.kr

SINGAPORE
KEC SINGAPORE PTE., LTD.
PHONE : +65-6748-7372(#102)
kec_twn@kec.co.kr

THAILAND
KEC THAILAND BANGKOK OFFICE
PHONE : +66-2-576-1484~5
kec_th@kec.co.kr

CHINA
KEC SHANGHAI CO.,LTD.
PHONE : +86-21-5490-2277
kec_sh@kec.co.kr

KEC SHENZHEN OFFICE
PHONE : +86-755-8882-9198
kec_hk@kec.co.kr

KEC TIANJIN OFFICE
PHONE : + 86-21-5490-2277
kec_sh@kec.co.kr

HONG KONG
KEC HK CORP. LTD
PHONE : +852-2249-3734
kec_hk@kec.co.kr

TAIWAN
KEC TAIWAN CO.,LTD.
PHONE : +886-2-2515-8359
kec_twn@kec.co.kr

U.S.A
KEC AMERICA CORP.
PHONE : +1-714-259-0662
kec_a@kec.co.kr

