

DC/DC Converter Controller

The KIA34063A/AF series is a monolithic control circuit containing the primary functions required for DC-to-DC converters. These devices consist of an internal temperature compensated reference, comparator, controlled duty cycle oscillator with an active current limit circuit, driver and high current output switch. This series was specifically designed to be incorporated in Step-Down and Step-Up and Voltage-Inverting applications with a minimum number of external components.

FEATURES

- Operation from 3.0V to 40V input.
- Low Standby Current.
- Current Limiting.
- Output Switch Current to 1.5A.
- Output Voltage Adjustable.
- Frequency Operation to 100kHz.
- Precision 2% Reference.

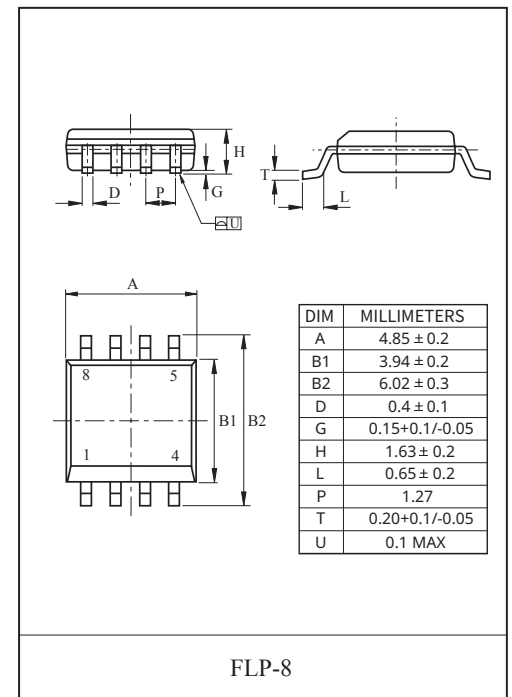
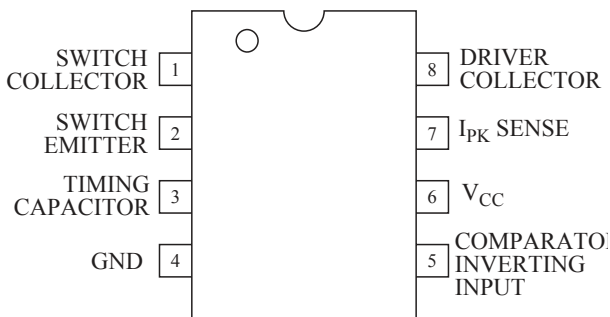
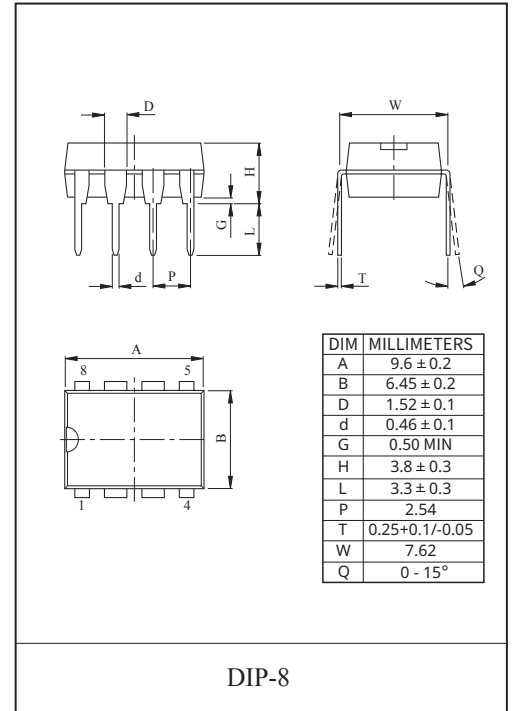

KIA34063A/AF

ELECTRICAL CHARACTERISTICS ($V_{CC}=5.0V$, $T_a=25^\circ C$, unless otherwise specified)

OSCILLATOR SECTION

CHARACTERISTIC	SYMBOL	TEST CONDITION	MIN.	TYP.	MAX.	UNIT
Frequency	f_{OSC}	$V_{PIN5}=0V$, $C_T=1.0nF$	24	33	42	kHz
Charge Current	I_{CHG}	$V_{CC}=5.0 \sim 40V$	24	35	42	μA
Discharge Current	I_{DISCHG}	$V_{CC}=5.0 \sim 40V$	140	220	260	μA
Discharge to Charge Current Ratio	I_{DISCHG}/I_{CHG}	Pin 7 $\sim V_{CC}$	5.2	6.5	7.5	-
Current Limit Sense Voltage	$V_{IPK(SENSE)}$	$I_{DISCHG}=I_{CHG}$	250	300	350	mV

OUTPUT SWITCH SECTION (Note 2)

CHARACTERISTIC	SYMBOL	TEST CONDITION	MIN.	TYP.	MAX.	UNIT
Saturation Voltage, Darlington Connection	$V_{CE(SAT1)}$	$I_{SW}=1.0A$, Pins 1, 8 Connection	-	1.0	1.3	V
Saturation Voltage (Note 3)	$V_{CE(SAT2)}$	$I_{SW}=1.0A$, Forced $\beta \approx 20$ $R_{PIN8}=82\Omega$ to V_{CC}	-	0.45	0.7	V
DC Current Gain	h_{FE}	$I_{SW}=1.0A$, $V_{CE}=5.0A$,	50	75	-	-
Collector Off-State Current	$I_{C(OFF)}$	$V_{CE}=40V$	-	0.01	100	μA

COMPARATOR SECTION

CHARACTERISTIC	SYMBOL	TEST CONDITION	MIN.	TYP.	MAX.	UNIT
Threshold Voltage	V_{TH1}	$T_a=25^\circ C$	1.225	1.25	1.275	V
Threshold Voltage	V_{TH2}	$T_a=T_{LOW} \sim T_{HIGH}$	1.21	-	1.29	V
Threshold Voltage Line Regulation	Reg line	$V_{CC}=3.0 \sim 40V$	-	1.4	5.0	mV
Input Bias Current	I_{IB}	$V_{IN}=0$	-	-20	-400	nA

TOTAL DEVICE

CHARACTERISTIC	SYMBOL	TEST CONDITION	MIN.	TYP.	MAX.	UNIT
Supply Current	I_{CC}	$V_{CC}=5.0 \sim 40V$, $C_T=1.0nF$, Pin 7= V_{CC} , Pin 2= GND , $V_{PIN5} > V_{TH}$, remaining pins open	-	-	4.0	mA

Note) 2. Low duty cycle pulse techniques are used during test to maintain junction temperature as close to ambient temperature as possible.

3. If the output switch is driven into hard saturation (non-Darlington configuration) at low switch currents ($\leq 300mA$) and high driver currents ($\geq 30mA$), it may take up to 2.0 μS for it to come out of saturation. This condition will shorten the off time at frequencies $\geq 30kHz$, and is magnified at high temperatures. This condition does not occur with a Darlington configuration, since the output switch cannot saturate. If a non-Darlington configuration is used, the following output drive condition is recommended ;

$$\text{Forced } \beta \text{ of output switch : } \frac{I_C \text{ output}}{I_C \text{ driver}-7.0mA} \geq 10$$

* The 100 Ω resistor in the emitter of the driver device requires about 7.0mA before the output switch conducts.

KIA34063A/AF

APPLICATION CIRCUIT

(1) Step-up Converter

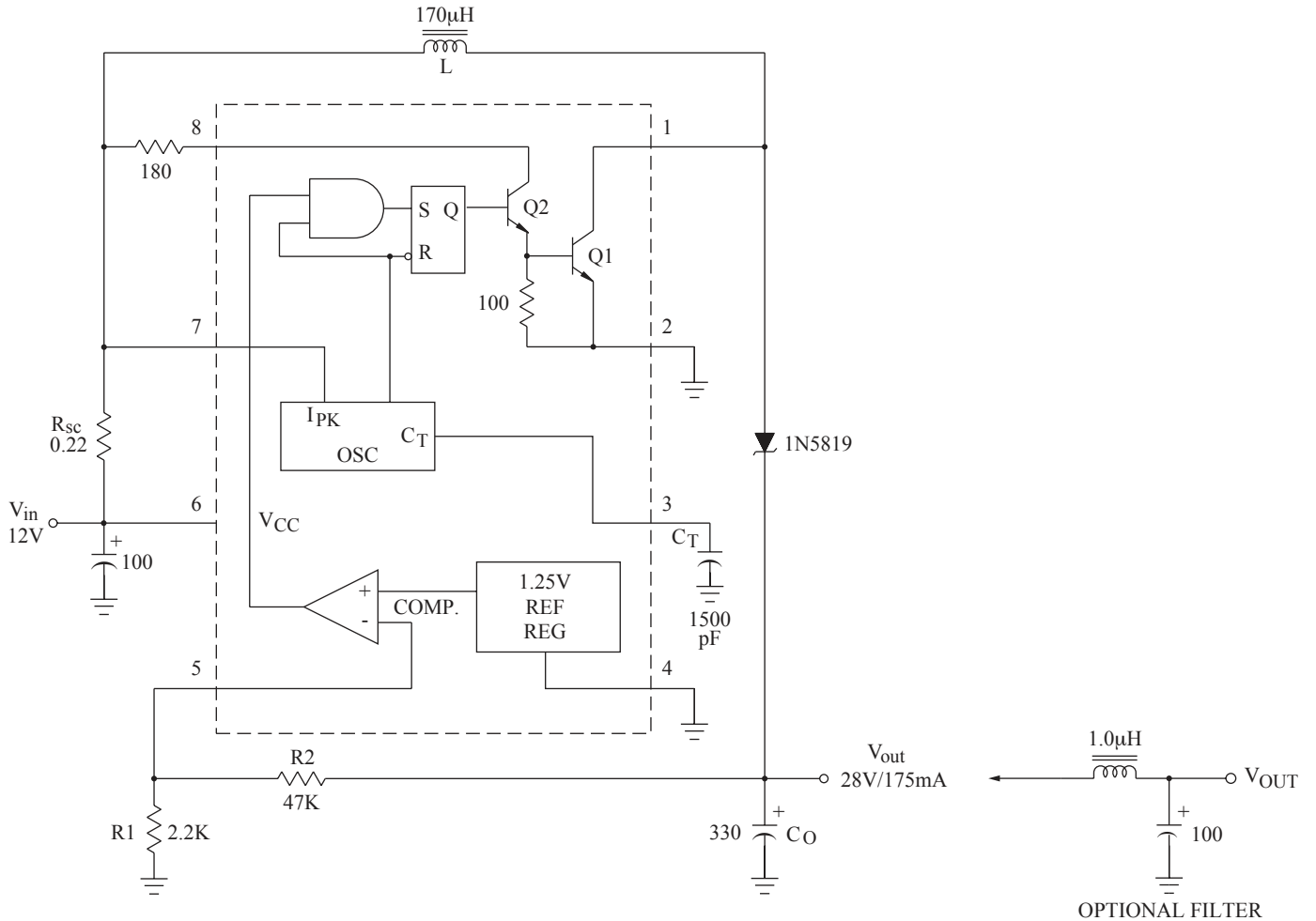

TEST	CONDITIONS	RESULTS
Line Regulation	$V_{IN}=8.0V$ to $16V$, $I_O=175mA$	$30mV=\pm 0.05\%$
Load Regulation	$V_{IN}=12V$, $I_O=75mA$ to $175mA$	$10mV=\pm 0.017\%$
Output Ripple	$V_{IN}=12V$, $I_O=175mA$	400 mVpp
Efficiency	$V_{IN}=12V$, $I_O=175mA$	87.7%
Output Ripple With Optional Filter	$V_{IN}=12V$, $I_O=175mA$	40 mVpp

KIA34063A/AF

(2) Step-Down Converter

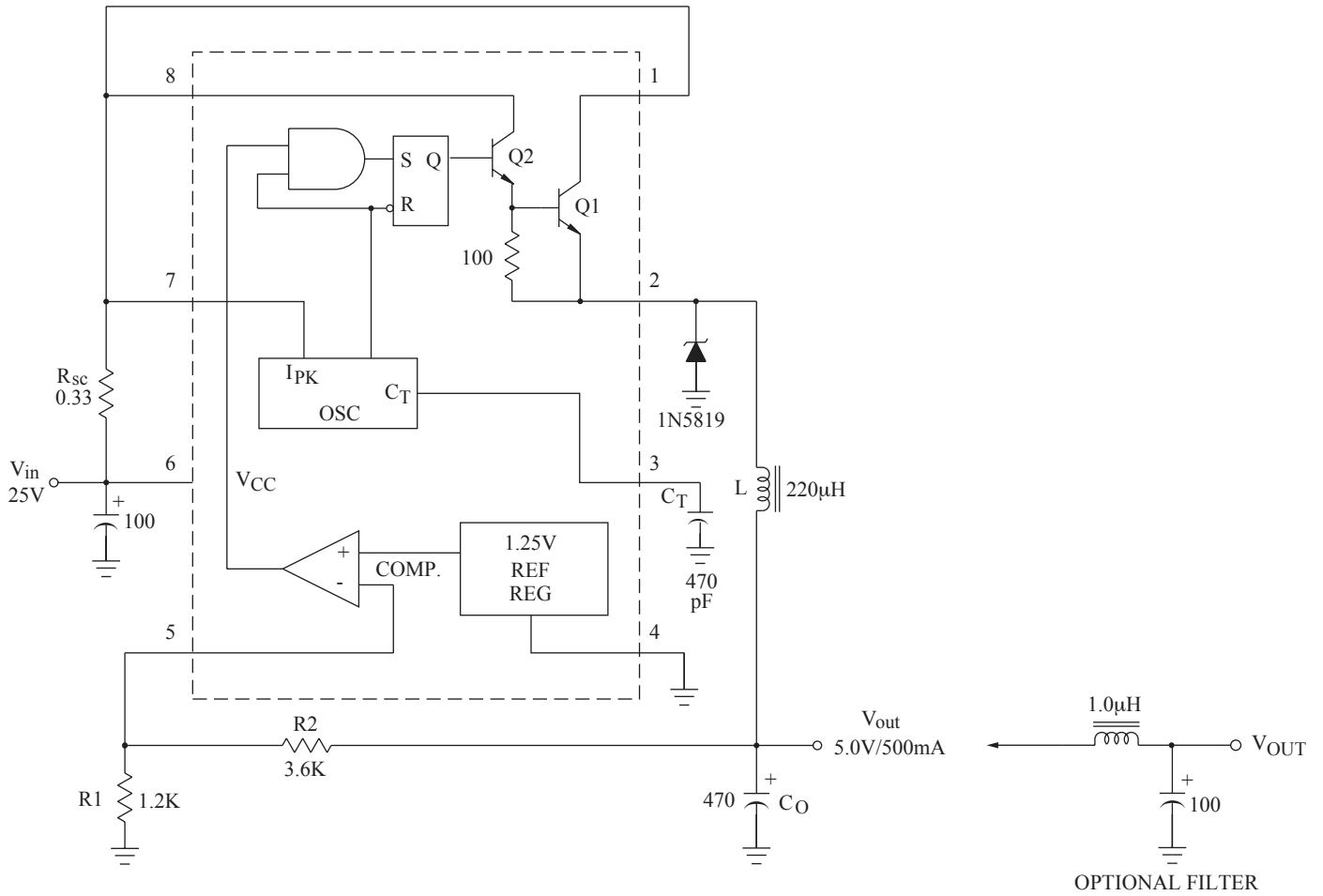

TEST	CONDITIONS	RESULTS
Line Regulation	$V_{IN}=15V$ to $25V$, $I_O=500mA$	$12mV=\pm 0.12\%$
Load Regulation	$V_{IN}=25V$, $I_O=50mA$ to $500mA$	$3.0mV=\pm 0.03\%$
Output Ripple	$V_{IN}=25V$, $I_O=500mA$	120 mVpp
Short Circuit Current	$V_{IN}=25V$, $R_L=0.1\ \Omega$	$1.1A$
Efficiency	$V_{IN}=25V$, $I_O=500mA$	83.7%
Output Ripple With Optional Filter	$V_{IN}=25V$, $I_O=500mA$	40 mVpp

KIA34063A/AF

(2) Voltage Inverting Converter

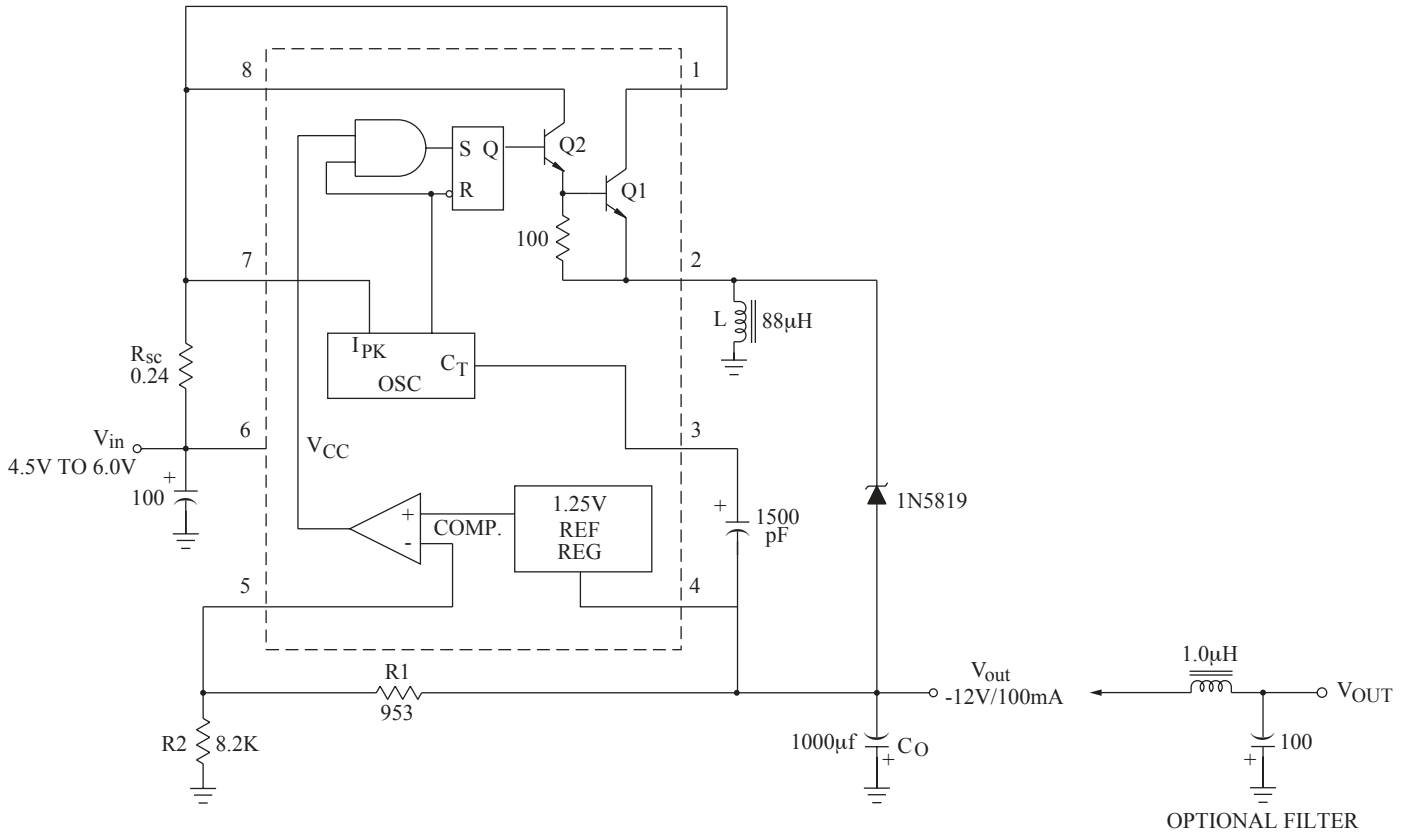

TEST	CONDITIONS	RESULTS
Line Regulation	$V_{IN}=4.5V$ to $6.0V$, $I_O=100mA$	$3.0mV=\pm 0.012\%$
Load Regulation	$V_{IN}=5.0V$, $I_O=10mA$ to $100mA$	$0.022V=\pm 0.09\%$
Output Ripple	$V_{IN}=5.0V$, $I_O=100mA$	500 mVpp
Short Circuit Current	$V_{IN}=5.0V$, $R_L=0.1\Omega$	$910mA$
Efficiency	$V_{IN}=5.0V$, $I_O=100mA$	62.2%
Output Ripple With Optional Filter	$V_{IN}=5.0V$, $I_O=100mA$	70 mVpp

KIA34063A/AF

$t_{on}, t_{off} - C_T$

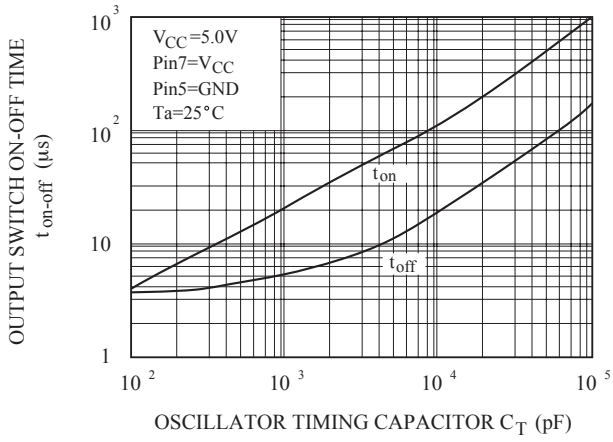

TIMING CAPACITOR WAVEFORM

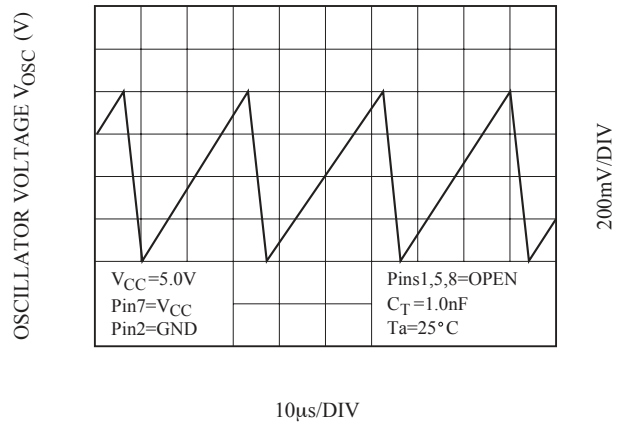

$V_{CE(sat)} - I_E$

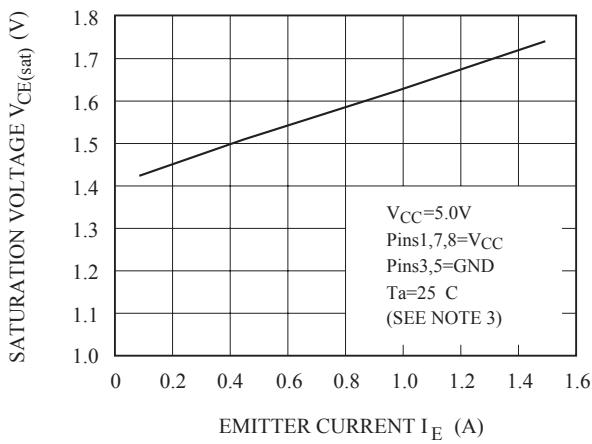

$V_{CE(sat)} - I_C$

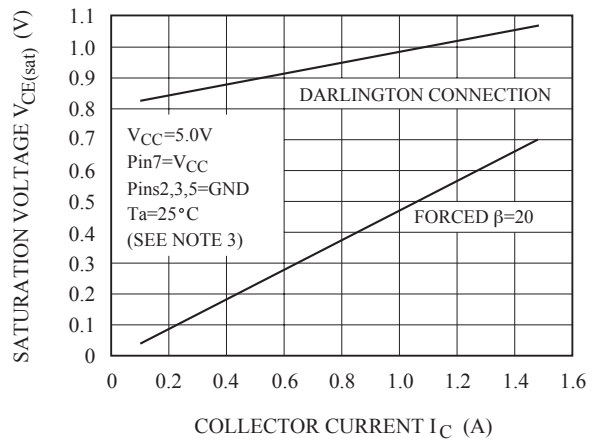

$V_{IPK(SENSE)} - T_a$

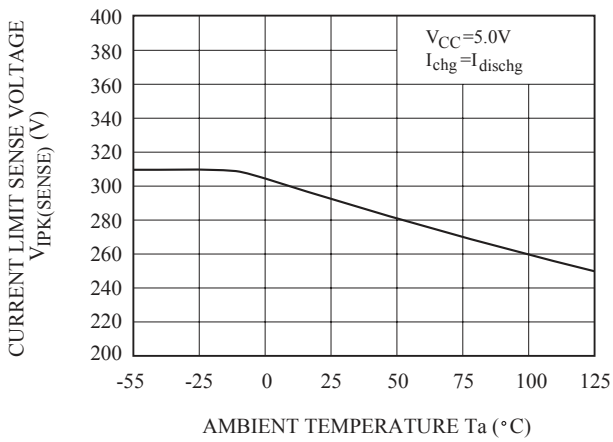

$I_{CC} - V_{CC}$

