

DUAL COMPARATOR

FEATURES

- Be Possible to Operate at the Wide Range Single or Two Supply Voltage.
- Low Supply Current : $I_{CC}=0.8mA(Typ.)$.
- Low Input Offset Voltage : $V_{IO}=2mV(Typ.)$.
- Wide Common Mode Input Voltage : $0V_{DC}$ to $V_{CC}-1.5V_{DC}$.
- Output is Compatible with TTL, DTL, MOS and C-MOS.
- Output is Open Collector and Wired-OR Possible.
- ESD Protection (JEDEC-JESD22).
 - 2000V Human Body Model (A114, CLASS II).
 - 200V Machine Model (A115, CLASS B).
- Suffix U : Qualified to AEC-Q100 (Grade 1)
 - ex) KIA393F-EL/PU

PIN CONNECTION(TOP VIEW)

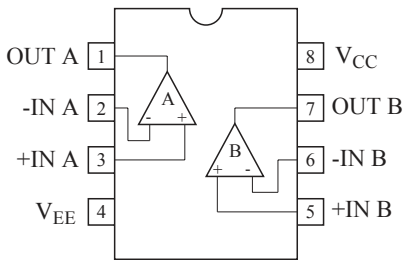

MARKING

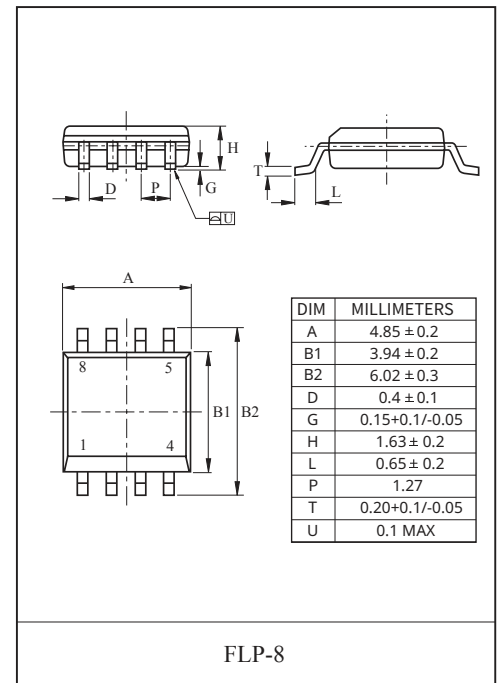
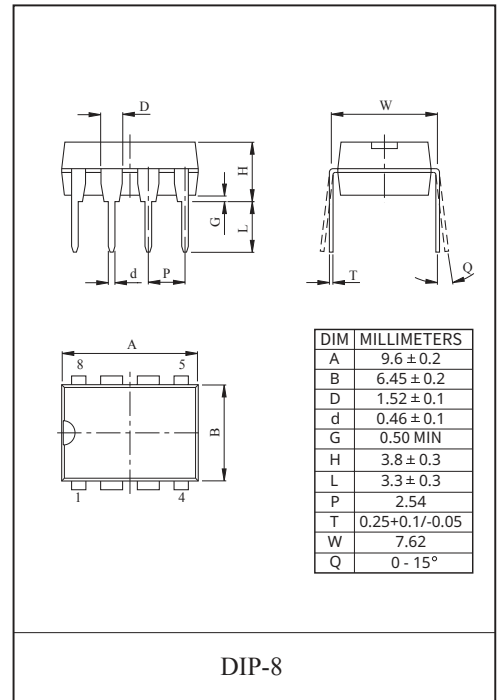
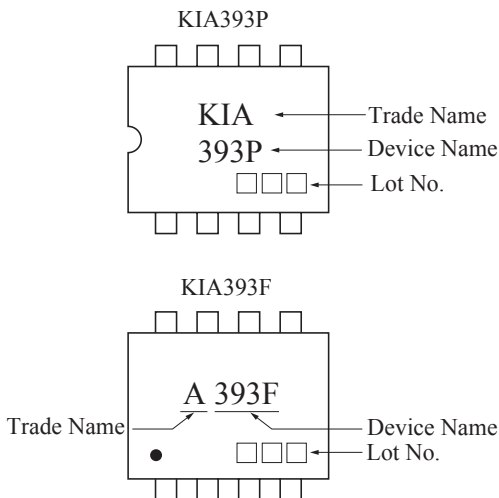

KIA393P/F

EQUIVALENT CIRCUIT

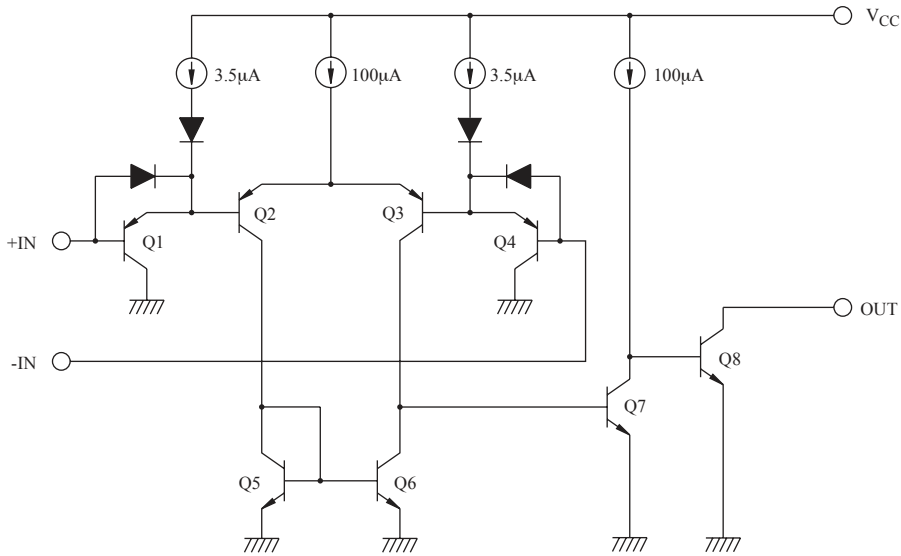

MAXIMUM RATINGS (Ta=25°C)

CHARACTERISTIC		SYMBOL	RATING	UNIT
Supply Voltage		V_{CC}	$\pm 18, 36$	V
Differential Input Voltage		DV_{IN}	$\pm 18, 36$	V
Common Mode Input Voltage		CMV_{IN}	$-0.3 \sim V_{CC}$	V
Power Dissipation	KIA393P	P_D	500	mW
	KIA393F		240	
Junction Temperature		T_j	150	°C
Operating Temperature		T_{opr}	$-40 \sim 125$	°C
Storage Temperature		T_{stg}	$-55 \sim 150$	°C

ELECTRICAL CHARACTERISTICS (V_{CC}=5V, V_{EE}=GND, Ta=25°C)

CHARACTERISTIC	SYMBOL	TEST CONDITION	MIN.	TYP.	MAX.	UNIT
Input Offset Voltage	V_{IO}	$V_O=1.4V$	-	2	5	mV
Input Offset Current	I_{IO}	-	-	5	50	nA
Input Bias Current	I_I	-	-	25	250	nA
Common Mode Input Voltage	CMV_{IN}	-	0	-	$V_{CC}-1.5$	V
Voltage Gain	G_V	$R_L=15k\Omega$	-	200	-	V/mV
Supply Current	I_{CC}	No load	-	0.8	2	mA
Sink Current	I_{sink}	+IN=0V, -IN=1V, $V_{OL}=1.5V$	6	16	-	mA
Output Voltage ("L" Level)	V_{OL}	+IN=0V, -IN=1V, $I_{sink}=3mA$	-	0.2	0.4	V
Output Leak Current	I_{LEAK}	+IN=1V, -IN=0V, $V_O=5V$	-	0.1	-	nA
Response Time	t_{rsp}	$R_L=5.1k\Omega$, $C_L=15pF$	-	1.3	-	µs

KIA393P/F

Fig. 1 $V_{CC} - I_{CC}$

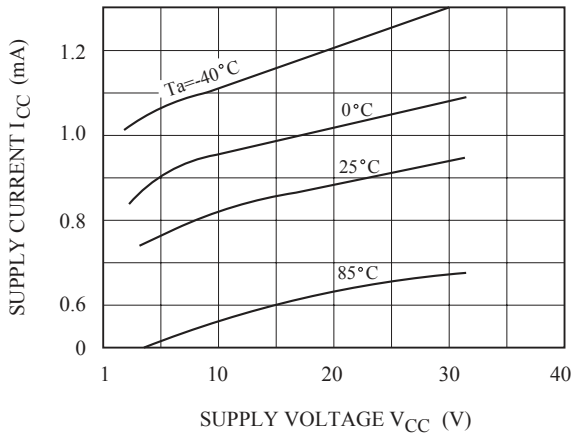

Fig. 2 $V_{CC} - I_I$

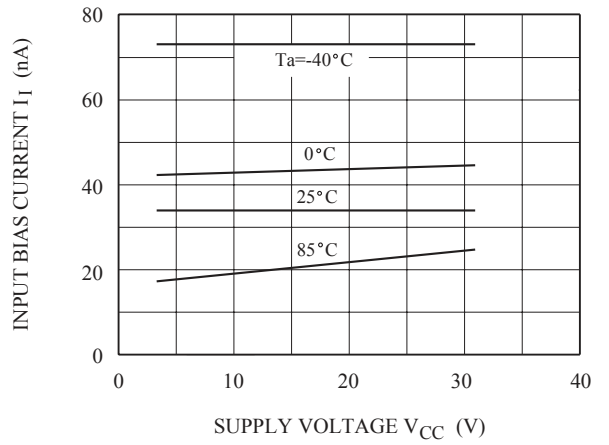

Fig. 3 $V_{OL} - I_{SINK}$

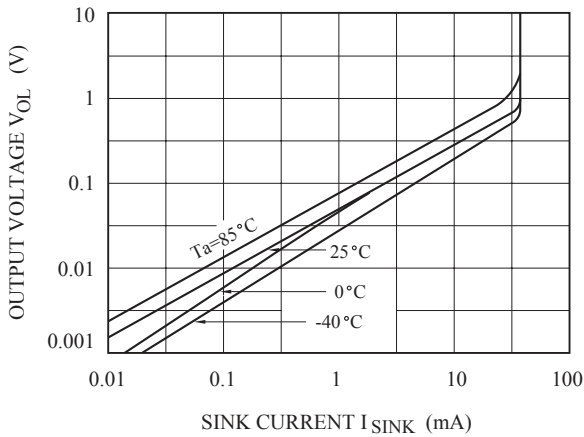

Fig. 4 $V_{IN}, V_{OUT} - t_{rsp}$

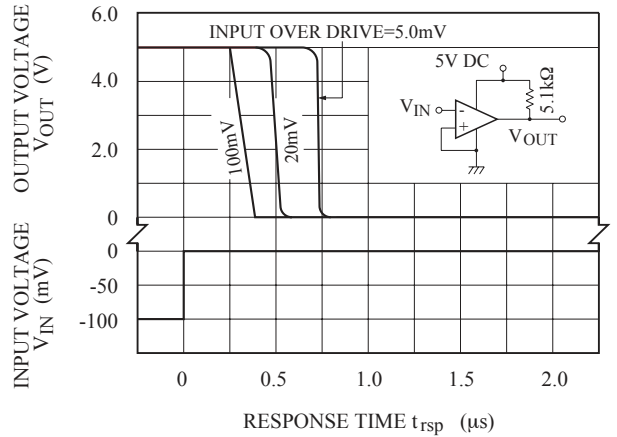

Fig. 5 $V_{IN}, V_{OUT} - t_{rsp}$

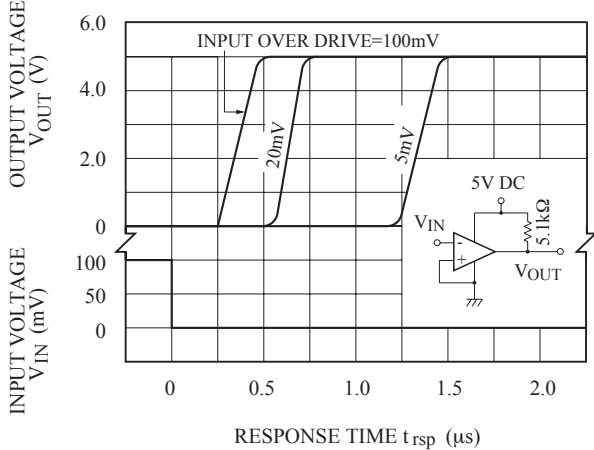

Fig. 6 $P_D - T_a$

