

POWER AMPLIFIER APPLICATION.
POWER SWITCHING APPLICATION.

FEATURES

- Low Collector Saturation Voltage :
 $V_{CE(sat)} = -0.5V(\text{Max.}) (I_C = -1A)$
- High Speed Switching Time : $t_{stg} = 1\mu S(\text{Typ.})$
- Complementary to KTC2815D.
- Suffix U : Qualified to AEC-Q 101
ex) KTA1718D-O-RTF/HU

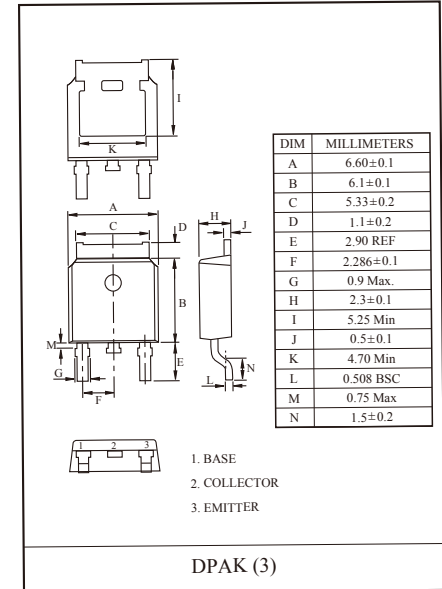
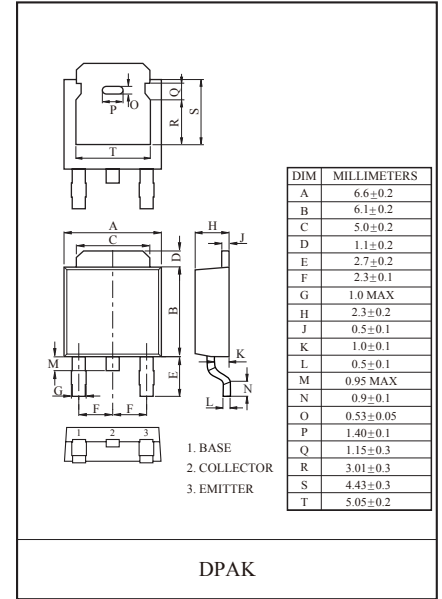

MAXIMUM RATING (Ta=25 °C)

CHARACTERISTIC	SYMBOL	RATING	UNIT
Collector-Base Voltage	V_{CBO}	-50	V
Collector-Emitter Voltage	V_{CEO}	-50	V
Emitter-Base Voltage	V_{EBO}	-5	V
Collector Current	I_C	-2	A
Collector Power Dissipation	P_C	Ta=25 °C	1.0
		Tc=25 °C	10
Junction Temperature	T_j	150	°C
Storage Temperature Range	T_{stg}	-55 ~ 150	°C

ELECTRICAL CHARACTERISTICS (Ta=25°C)

CHARACTERISTIC	SYMBOL	TEST CONDITION	MIN.	TYP.	MAX.	UNIT
Collector Cut-off Current	I_{CBO}	$V_{CB} = -50V, I_E = 0$	-	-	-0.1	μA
Emitter Cut-off Current	I_{EBO}	$V_{EB} = -5V, I_C = 0$	-	-	-0.1	μA
Collector-Emitter Breakdown Voltage	$V_{(BR)CEO}$	$I_C = -10mA, I_B = 0$	-50	-	-	V
DC Current Gain	$h_{FE(1)}$ (Note)	$V_{CE} = -2V, I_C = -0.5A$	70	-	240	
	h_{FE2}	$V_{CE} = -2V, I_C = -1.5A$	40	-	-	
Collector-Emitter Saturation Voltage	$V_{CE(sat)}$	$I_C = -1A, I_B = -0.05A$	-	-	-0.5	V
Base-Emitter Saturation Voltage	$V_{BE(sat)}$	$I_C = -1A, I_B = -0.05A$	-	-	-1.2	V
Transition Frequency	f_T	$V_{CE} = -2V, I_C = -0.5A$	-	100	-	MHz
Collector Output Capacitance	C_{ob}	$V_{CB} = -10V, I_E = 0, f = 1MHz$	-	30	-	pF
Switching Time	Turn On Time	t_{on}	-	0.1	-	μS
	Storage Time	t_{stg}	-	1.0	-	
	Fall Time	t_f	-	0.1	-	

$-I_{B1} = I_{B2} = 0.05A$
DUTY CYCLE ≤ 1%

Note : $h_{FE(1)}$ Classification O:70~140, Y:120~240.

KTA1718D

STATIC CHARACTERISTICS

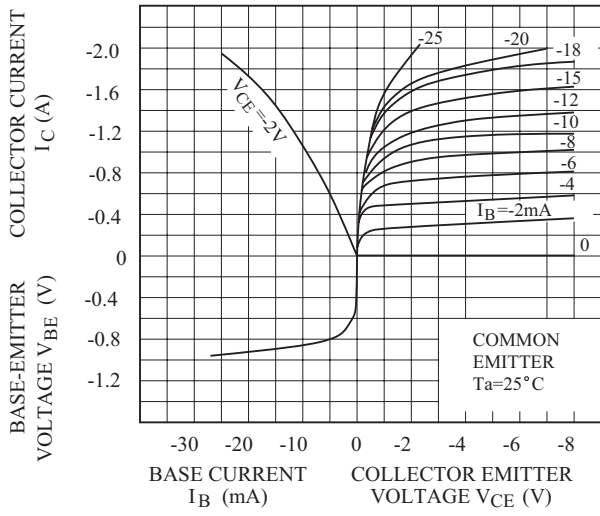

$V_{CE} - I_C$

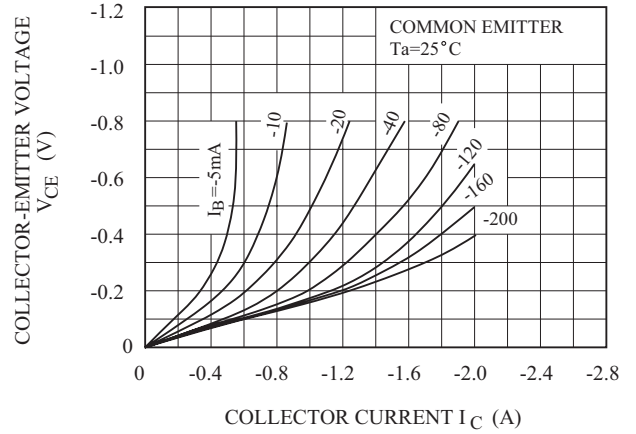

$V_{CE} - I_C$

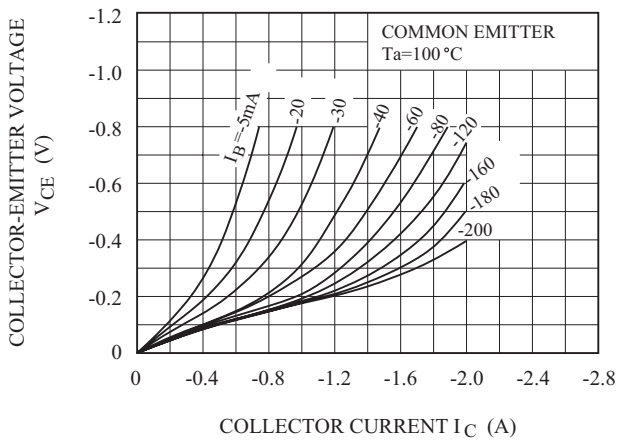

$V_{CE} - I_C$

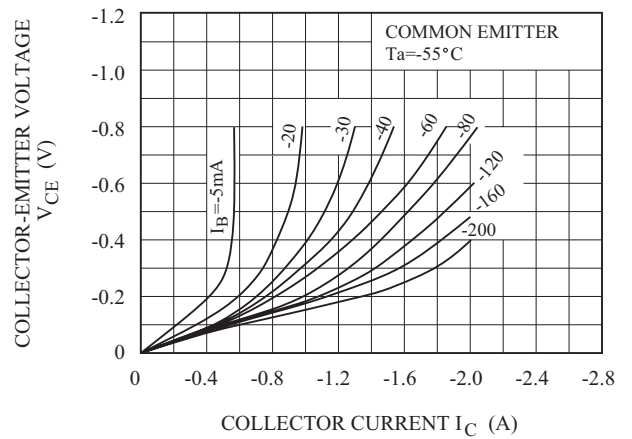

$h_{FE} - I_C$

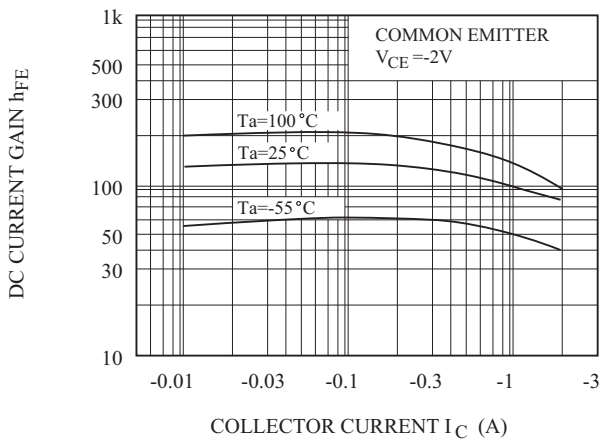

KTA1718D

