

### HIGH VOLTAGE APPLICATION.

### FEATURES

- High Transition Frequency :  $f_T=100\text{MHz(Typ.)}$ .
- Complementary to KTA1225D

### MAXIMUM RATING (Ta=25 °C)

CHARACTERISTIC		SYMBOL	RATING	UNIT
Collector-Base Voltage		$V_{CBO}$	160	V
Collector-Emitter Voltage		$V_{CEO}$	160	V
Emitter-Base Voltage		$V_{EBO}$	5	V
Collector Current		$I_C$	1.5	A
Base Current		$I_B$	1.0	A
Collector Power Dissipation	Ta=25 °C	$P_C$	1.0	W
	Tc=25 °C		10	
Junction Temperature		$T_j$	150	°C
Thermal Resistance		$R_{th(j-a)}$	125	°C/W
		$R_{th(j-c)}$	12.5	°C/W
Storage Temperature Range		$T_{stg}$	-55 ~ 150	°C

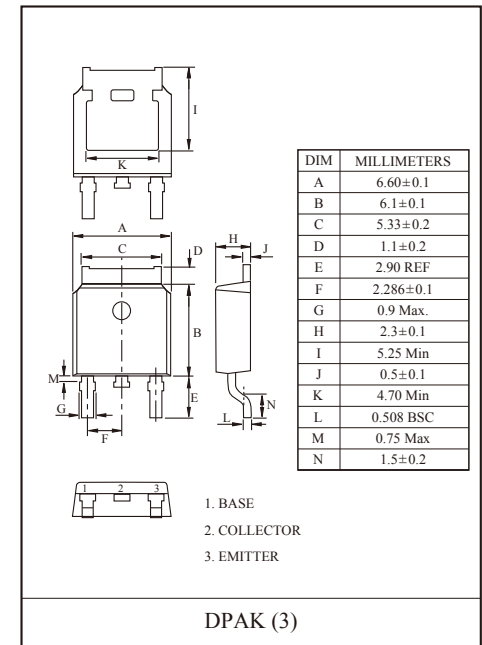
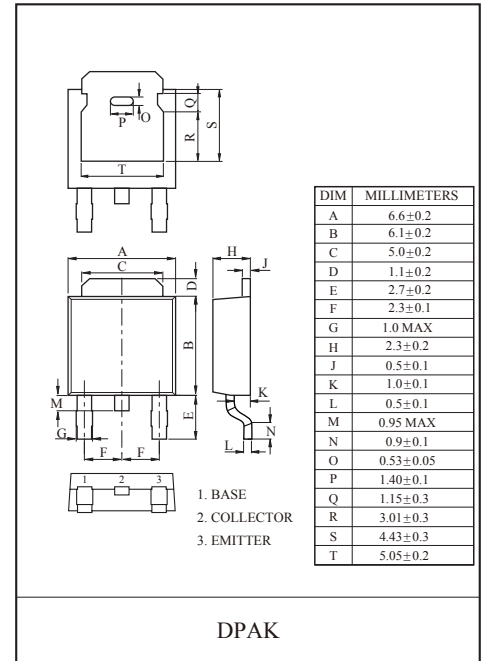

### ELECTRICAL CHARACTERISTICS (Ta=25 °C)

CHARACTERISTIC	SYMBOL	TEST CONDITION	MIN.	TYP.	MAX.	UNIT
Collector Cut-off Current	$I_{CBO}$	$V_{CB}=160\text{V}, I_E=0$	-	-	1.0	μA
Emitter Cut-off Current	$I_{EBO}$	$V_{EB}=5\text{V}, I_C=0$	-	-	1.0	μA
Collector-Emitter Breakdown Voltage	$V_{(BR)CEO}$	$I_C=10\text{mA}, I_B=0$	160	-	-	V
Emitter-Base Breakdown Voltage	$V_{(BR)EBO}$	$I_E=1\text{mA}, I_C=0$	5.0	-	-	V
DC Current Gain	$h_{FE}(\text{Note})$	$V_{CE}=5\text{V}, I_C=100\text{mA}$	70	-	240	
Collector-Emitter Saturation Voltage	$V_{CE(sat)}$	$I_C=500\text{mA}, I_B=50\text{mA}$	-	-	1.5	V
Base-Emitter Voltage	$V_{BE}$	$V_{CE}=5\text{V}, I_C=500\text{mA}$	-	-	1.0	V
Transition Frequency	$f_T$	$V_{CE}=10\text{V}, I_C=100\text{mA}$	-	100	-	MHz
Collector Output Capacitance	$C_{ob}$	$V_{CB}=10\text{V}, I_E=0, f=1\text{MHz}$	-	25	-	pF

Note :  $h_{FE}$  Classification O:70~140, Y:120~240

# KTC2983D

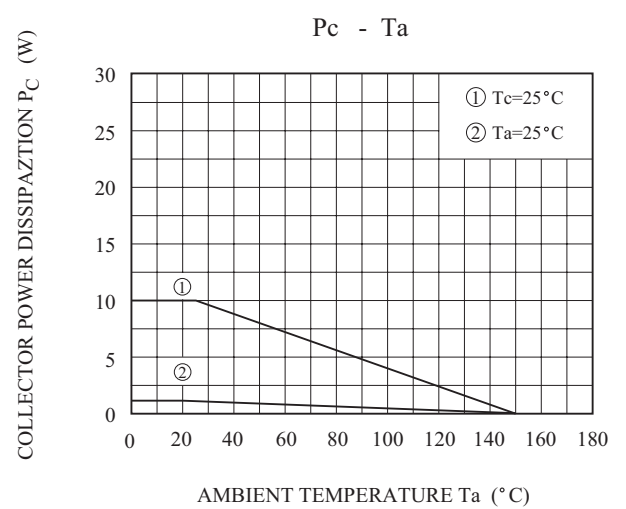
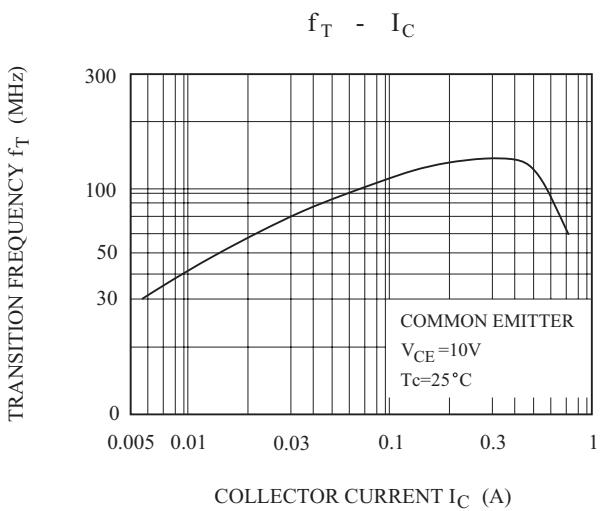
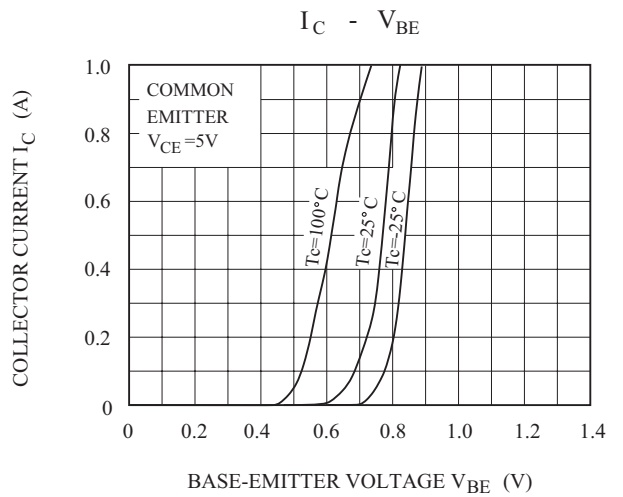
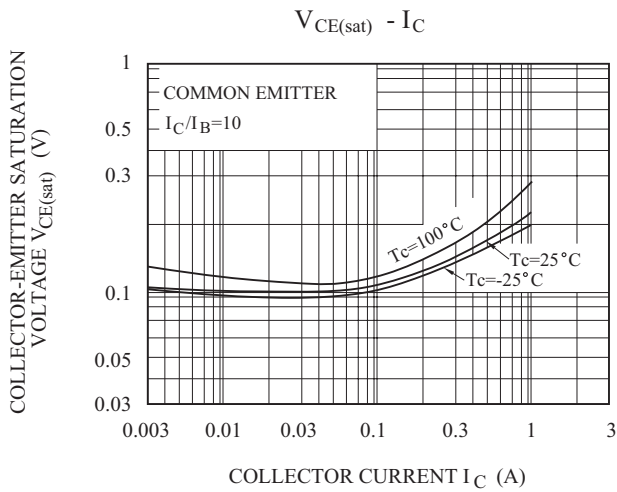
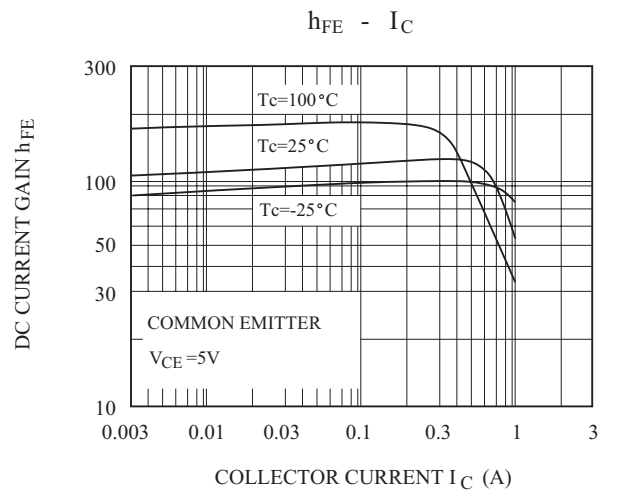
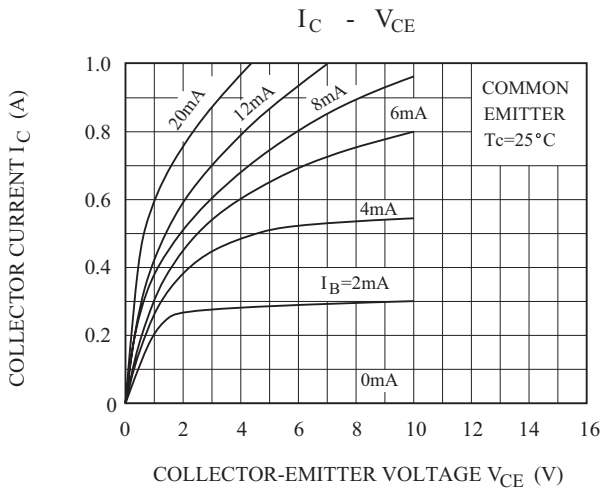

# KTC2983D

SAFE OPERATING AREA

