

HIGH VOLTAGE APPLICATION.
TELEPHONE APPLICATION.

FEATURES

- Complementary to MPSA92/93.

MAXIMUM RATING (Ta=25 °C)

CHARACTERISTIC		SYMBOL	RATING	UNIT
Collector-Base Voltage	MPSA42	V_{CBO}	300	V
	MPSA43		200	
Collector-Emitter Voltage	MPSA42	V_{CEO}	300	V
	MPSA43		200	
Emitter-Base Voltage		V_{EBO}	6.0	V
Collector Current		I_C	500	mA
Emitter Current		I_E	-500	mA
Collector Power Dissipation		P_C	625	mW
Junction Temperature		T_j	150	°C
Storage Temperature Range		T_{stg}	-55 ~ 150	°C

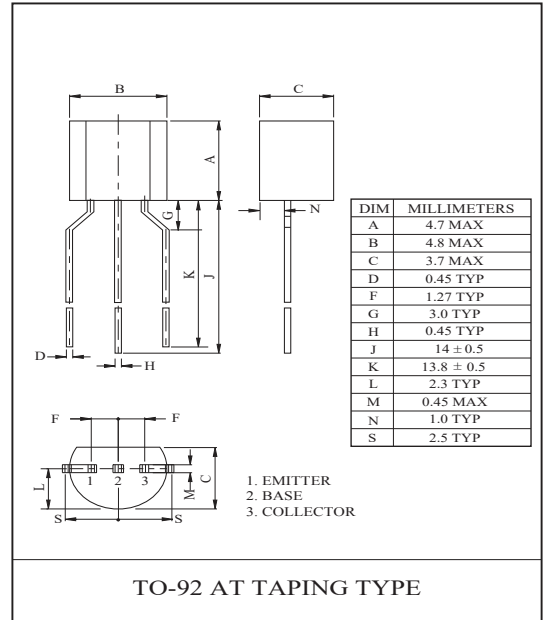
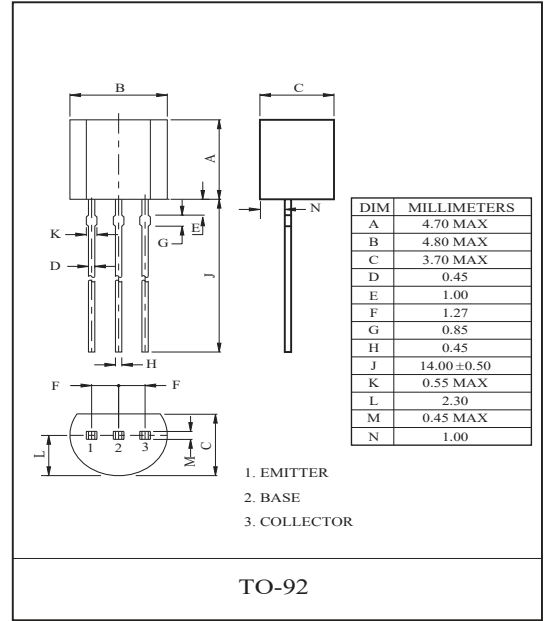

ELECTRICAL CHARACTERISTICS (Ta=25 °C)

CHARACTERISTIC		SYMBOL	TEST CONDITION	MIN.	TYP.	MAX.	UNIT
Collector-Base Breakdown Voltage	MPSA42	$V_{(BR)CBO}$	$I_C=100\mu A, I_E=0$	300	-	-	V
	MPSA43			200	-	-	
Collector-Emitter Breakdown Voltage	MPSA42	$V_{(BR)CEO}$	$I_C=1.0mA, I_B=0$	300	-	-	V
	MPSA43			200	-	-	
Collector Cut-off Current	MPSA42	I_{CBO}	$V_{CB}=200V, I_E=0$	-	-	0.1	μA
	MPSA43		$V_{CB}=160V, I_E=0$	-	-	0.1	
Emitter Cut-off Current	MPSA42	I_{EBO}	$V_{EB}=6V, I_C=0$	-	-	0.1	μA
	MPSA43		$V_{EB}=4V, I_C=0$	-	-	0.1	
DC Current Gain	* h_{FE}		$I_C=1.0mA, V_{CE}=10V$	40	-	-	
			$I_C=10mA, V_{CE}=10V$	40	-	-	
			$I_C=30mA, V_{CE}=10V$	40	-	-	
Collector-Emitter Saturation Voltage		* $V_{CE(sat)}$	$I_C=20mA, I_B=2.0mA$	-	-	0.5	V
Base-Emitter Saturation Voltage		* $V_{BE(sat)}$	$I_C=20mA, I_B=2.0mA$	-	-	0.9	V
Transition Frequency		f_T	$V_{CE}=20V, I_C=10mA, f=100MHz$	50	-	-	MHz
Collector Output Capacitance	MPSA42	C_{ob}	$V_{CB}=20V, I_E=0, f=1MHz$	-	-	3.0	pF
	MPSA43			-	-	4.0	

*Pulse Test : Pulse Width $\leq 300\mu s$, Duty Cycle $\leq 2.0\%$

MPSA42/43

