

DUAL OPERATIONAL AMPLIFIER

FEATURES

- In the Linear Mode the Input Common Mode Voltage Range Includes Ground.
- Two Internally Compensated OP Amps are in Single Package.
- Low Power Dissipation and Power Drain Suitable for Battery Operation.
- Differential Input Voltage Range Equal to the Power Supply Voltage.
- Wide Power Supply Voltage Range and Signal Power Supply
: Single Supply $3V_{DC}$ to $36V_{DC}$ Dual Supplies $\pm 1.5V_{DC}$ to $\pm 18V_{DC}$
- Large Output Voltage Swing : $0V_{DC}$ to $V_{CC}-1.5V_{DC}$
- Low Input Biasing Current : $I_I=45nA_{DC}$ (Typ.)
- Suffix U : Qualified to AEC-Q100. (Grade 1)
ex) KIA358F-EL/PU

PIN CONNECTION (TOP VIEW)

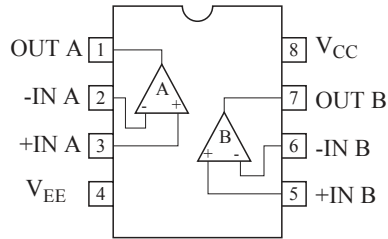

MARKING

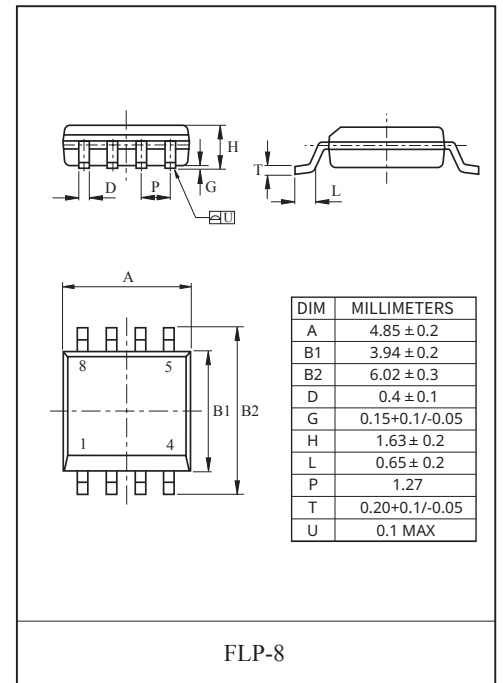
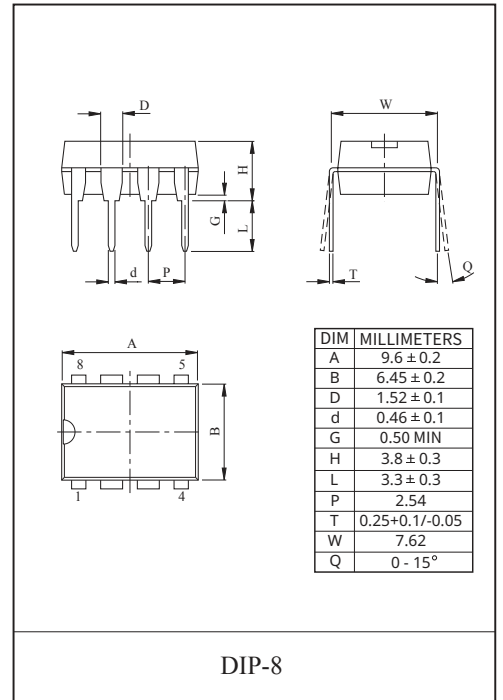
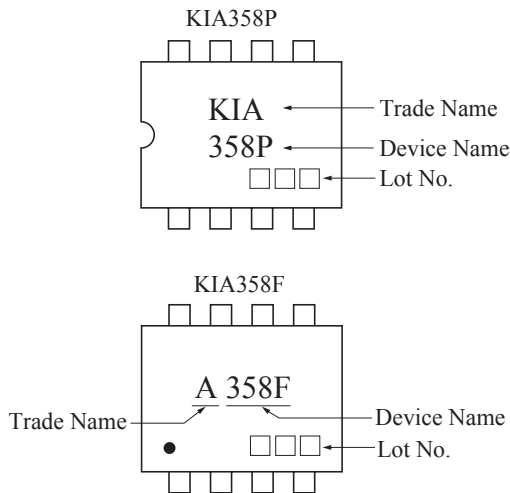

KIA358P/F

EQUIVALENT CIRCUIT

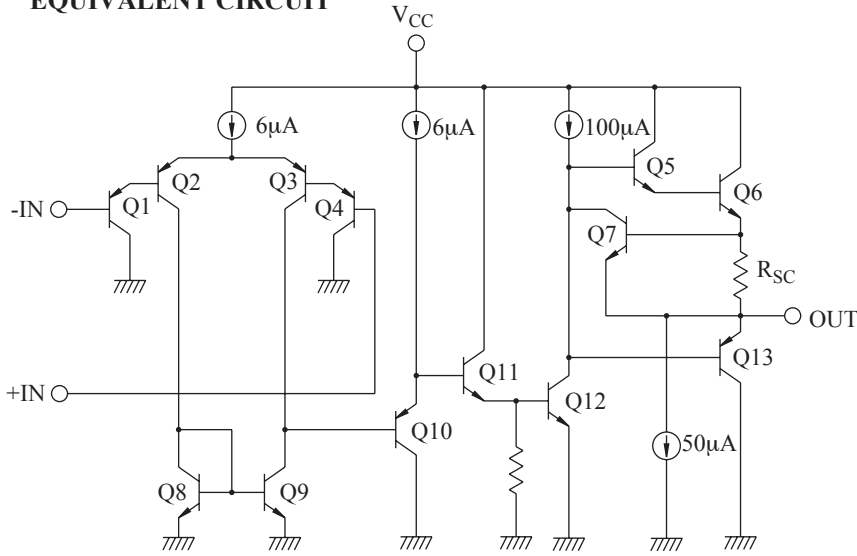

MAXIMUM RATINGS (Ta=25 °C)

CHARACTERISTIC	SYMBOL	RATING	UNIT
Supply Voltage	V_{CC}	36, 18	V
	V_{EE}	0, -18	
Differential Input Voltage	DV_{IN}	± 36	V
Input Voltage	V_{IN}	-0.3 ~ 36	V
Power Dissipation	P_D	KIA358P	500
		KIA358F	280
Junction Temperature	T_j	150	°C
Operating Temperature	T_{opr}	-40 ~ 125	°C
Storage Temperature	T_{stg}	-55 ~ 150	°C

ELECTRICAL CHARACTERISTICS ($V_{CC}=5V$, $V_{EE}=GND$, $T_a=25^\circ C$)

CHARACTERISTIC	SYMBOL	TEST CONDITION	MIN.	TYP.	MAX.	UNIT
Input Offset Voltage	V_{IO}	$R_g \leq 10k \Omega$	-	2	7	mV
Input Offset Current	I_{IO}	-	-	5	30	nA
Input Bias Current	I_I	-	-	45	150	nA
Common Mode Input Voltage	CMV_{IN}	$V_{CC}=30V$, $V_{EE}=GND$	0	-	$V_{CC}-1.5$	V
Supply Current	I_{CC} , I_{EE}	$R_L = \infty$, All OP Amps	-	0.7	1.2	mA
Voltage Gain	G_V	$R_L \geq 2k \Omega$	86	100	-	dB
Maximum Output Voltage Swing	V_{OP-P}	$R_L = 2k \Omega$	0	$V_{CC}-1.5$	-	V
Common Mode Input Signal Rejection Ratio	CMRR	-	60	85	-	dB
Supply Voltage Rejection Ratio	SVRR	$R_g = 10k \Omega$	60	100	-	dB
Slew rate	SR	$G_V = 1$, $R_L = 2k \Omega$	-	0.4	-	V/ μs
Source Current	I_{source}	-IN=0V _{DC} , +IN=1V _{DC}	20	40	-	mA
Sink Current	I_{sink}	-IN=1V _{DC} , +IN=0V _{DC}	10	20	-	mA

KIA358P/F

$V_{CC} - I_{CC}$

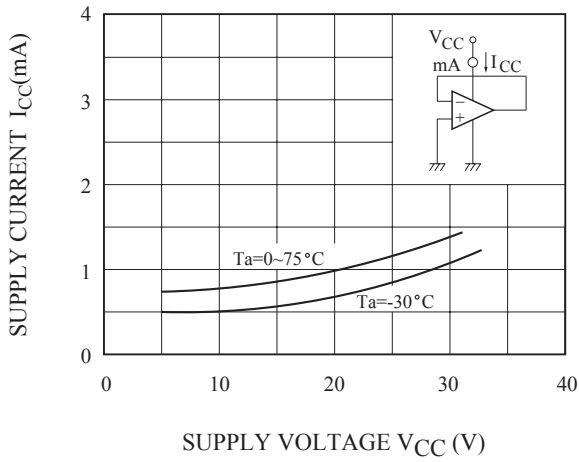

$V_{CC} - I_I$

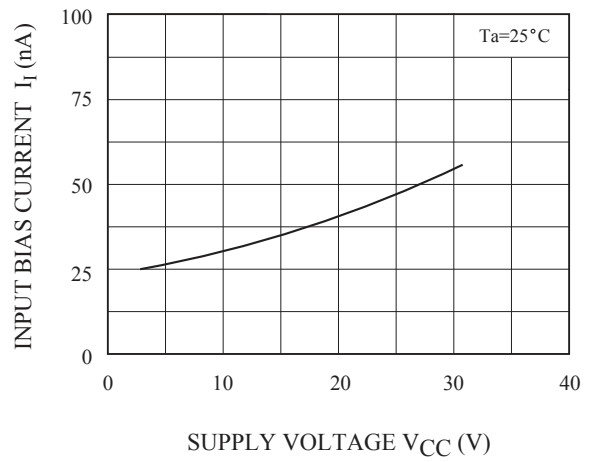

$V_{CC} - G_V$

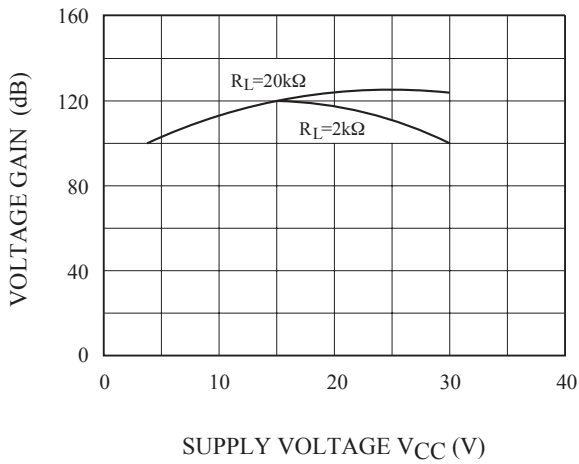

$I_{SOURCE} - T_a$

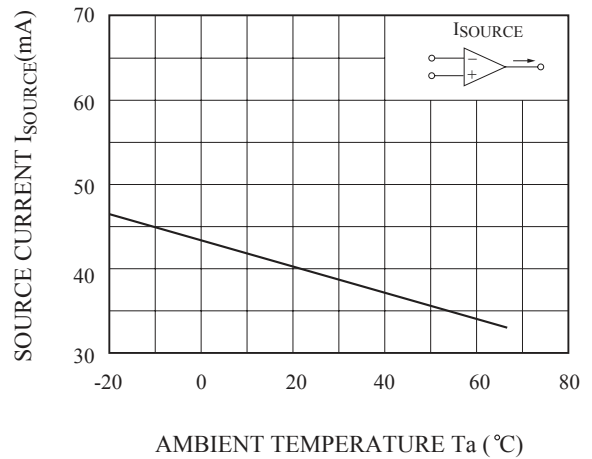

CMRR - f

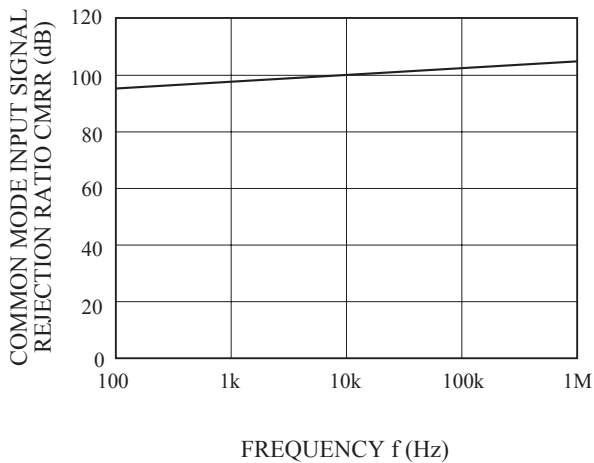

$G_V - f$

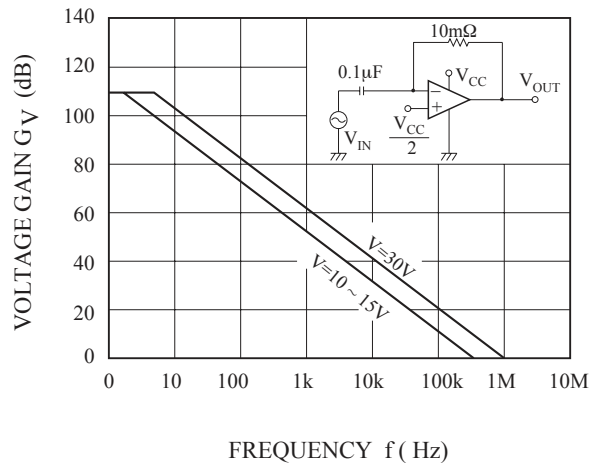

KIA358P/F

