

CMOS System Reset IC with Delay Time Circuit Monolithic IC KIC76** Series

In various CPU systems or other logic systems, when the time of a power supply injection and a power supply are severed for a moment, this IC detects supply voltage and applies reset to a system.

To 2% of detection voltage accuracy of the conventional product, a maximum of 1% of super-high precision is realized, and it is more suitable for battery detection etc.

FEATURES

- High accuracy : $\pm 1\%$ MAX
- Super low supply current : $0.35 \mu\text{A}$ typ.
- Operating-temperature range : $-40 \sim +105$
- Delay resistance accuracy : $10\text{M}\Omega \pm 10\%$
- Detecting voltage rank : $0.8 \sim 6.0\text{V}$ (0.1V step)
- Output type : Open drain output.
- Suffix U : Qualified to AEC-Q100.
ex) KIC76**T5-RTK/PU

Applications

- Reset circuits for CPUs and MPUs
- Reset circuits for logic circuits
- Battery voltage check circuits
- Back-up power supply switching circuits
- Level detection circuits

Pin Configuration

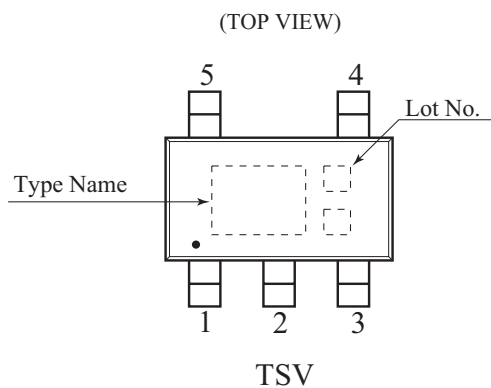

Pin Description

Pin No.	Pin name	Functions
1	V_{OUT}	Reset Signal Output Pin
2	V_{DD}	V_{DD} Pin / Voltage Detect Pin
3	GND	GND Pin
4	NC	No Connection
5	C_{D}	Capacitor Connect Pin with Delay

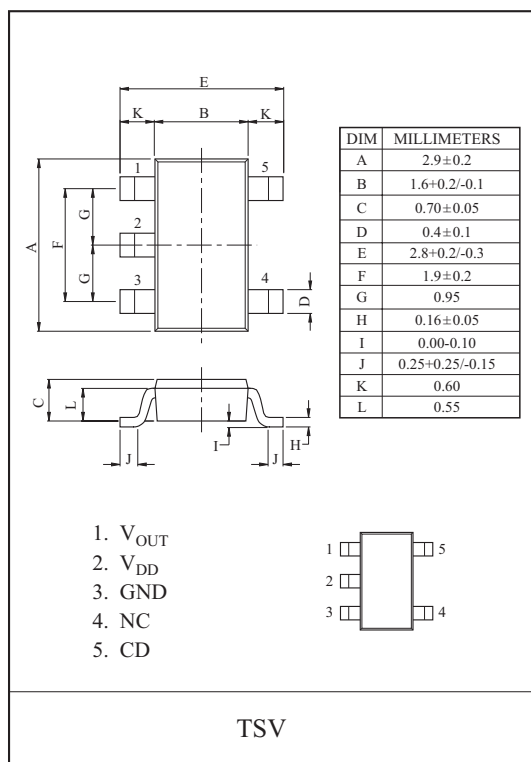

KIC7608~7660T5

Block Diagram

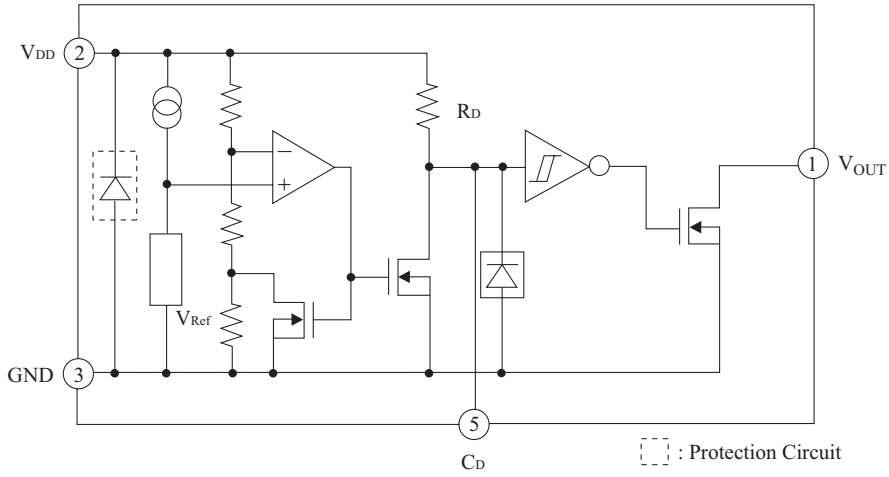

Figure. 1

Selection Guide

The Output voltage, package type for the ICs can be selected at the user's request. The selection can be made with designating the part number as shown below

KIC7 6 _____

NO.	Specifications	Description
	Function Code	External Delay
	Reset Voltage	0.8~6.0V
	Package	T5 TSV

KIC7608~7660T5

Absolute maximum ratings(Ta=25)

ITEM	SYMBOL	RATINGS	UNITS
Supply voltage	V _{DD MAX.}	-0.3 +12.0	V
Output voltage	V _{OUT}	-0.3 +12.0	V
Input current (V _{DD})	I _{DD}	20	mA
Output current ($\overline{\text{RESET}}$)	I _{OUT}	20	mA
C _D pin Input voltage	V _{CD}	V _{SS} -0.3 +12.0	V
Power dissipation	P _D	900 * Note)	mW
Operating Junction Temperature	T _j	-40~+150	
Operating temperature	T _{OPR}	-40~+105	
Storage temperature	T _{STG}	-65~+150	

* Note) Package Mounted on a Ceramic board (600mm² × 0.8mm)

Recommended Operating Conditions

ITEM	SYMBOL	RATINGS	UNITS
Operating Temperature	T _{opr}	-40 +105	
Supply voltage	V _{DD}	0.70~10.0	V

KIC7608~7660T5

Line-up

Detecting Voltage	KIC7608~25T5		Detecting Voltage	KIC7626~43T5		Detecting Voltage	KIC7644~60T5	
	Item	Marking		Item	Marking		Item	Marking
0.8V	KIC7608T5	608	2.6V	KIC7626T5	626	4.4V	KIC7644T5	644
0.9V	KIC7609T5	609	2.7V	KIC7627T5	627	4.5V	KIC7645T5	645
1.0V	KIC7610T5	610	2.8V	KIC7628T5	628	4.6V	KIC7646T5	646
1.1V	KIC7611T5	611	2.9V	KIC7629T5	629	4.7V	KIC7647T5	647
1.2V	KIC7612T5	612	3.0V	KIC7630T5	630	4.8V	KIC7648T5	648
1.3V	KIC7613T5	613	3.1V	KIC7631T5	631	4.9V	KIC7649T5	649
1.4V	KIC7614T5	614	3.2V	KIC7632T5	632	5.0V	KIC7650T5	650
1.5V	KIC7615T5	615	3.3V	KIC7633T5	633	5.1V	KIC7651T5	651
1.6V	KIC7616T5	616	3.4V	KIC7634T5	634	5.2V	KIC7652T5	652
1.7V	KIC7617T5	617	3.5V	KIC7635T5	635	5.3V	KIC7653T5	653
1.8V	KIC7618T5	618	3.6V	KIC7636T5	636	5.4V	KIC7654T5	654
1.9V	KIC7619T5	619	3.7V	KIC7637T5	637	5.5V	KIC7655T5	655
2.0V	KIC7620T5	620	3.8V	KIC7638T5	638	5.6V	KIC7656T5	656
2.1V	KIC7621T5	621	3.9V	KIC7639T5	639	5.7V	KIC7657T5	657
2.2V	KIC7622T5	622	4.0V	KIC7640T5	640	5.8V	KIC7658T5	658
2.3V	KIC7623T5	623	4.1V	KIC7641T5	641	5.9V	KIC7659T5	659
2.4V	KIC7624T5	624	4.2V	KIC7642T5	642	6.0V	KIC7660T5	660
2.5V	KIC7625T5	625	4.3V	KIC7643T5	643			

KIC7608~7660T5

Electrical characteristics (Unless Otherwise Specified Ta=25)

ITEM	SYMBOL	MEASUREMENT CONDITIONS	RANK	MIN.	TYP.	MAX.	UNITS	CIRCUIT
Reset Threshold	V_{TH}	Ta = +25 Ta = -40~+85	7608	0.792	0.8	0.808	V	(2)
				0.780	-	0.820		
			7609	0.891	0.9	0.909		
				0.878	-	0.923		
			7610	0.990	1.0	1.010		
				0.975	-	1.025		
			7611	1.089	1.1	1.111		
				1.073	-	1.128		
			7612	1.188	1.2	1.212		
				1.170	-	1.230		
			7613	1.287	1.3	1.313		
				1.268	-	1.333		
			7614	1.386	1.4	1.414		
				1.365	-	1.435		
			7615	1.485	1.5	1.515		
				1.463	-	1.538		
			7616	1.584	1.6	1.616		
				1.560	-	1.640		
			7617	1.683	1.7	1.717		
				1.658	-	1.743		
			7618	1.782	1.8	1.818		
				1.755	-	1.845		
			7619	1.881	1.9	1.919		
				1.853	-	1.948		
			7620	1.980	2.0	2.020		
				1.950	-	2.050		
			7621	2.079	2.1	2.121		
				2.048	-	2.153		
			7622	2.178	2.2	2.222		
				2.145	-	2.255		
			7623	2.277	2.3	2.323		
				2.243	-	2.358		
			7624	2.376	2.4	2.424		
				2.340	-	2.460		
			7625	2.475	2.5	2.525		
				2.438	-	2.563		
7626	2.574	2.6	2.626					
	2.535	-	2.665					
7627	2.673	2.7	2.727					
	2.633	-	2.768					
7628	2.772	2.8	2.828					
	2.730	-	2.870					
7629	2.871	2.9	2.929					
	2.828	-	2.973					
7630	2.970	3.0	3.030					
	2.925	-	3.075					

KIC7608~7660T5

Electrical characteristics (Unless Otherwise Specified Ta=25)

ITEM	SYMBOL	MEASUREMENT CONDITIONS	RANK	MIN.	TYP.	MAX.	UNITS	CIRCUIT
Reset Threshold	V_{TH}	Ta = +25 Ta = -40~+85	7631	3.069	3.1	3.131	V	(2)
				3.023	-	3.178		
			7632	3.168	3.2	3.232		
				3.120	-	3.280		
			7633	3.267	3.3	3.333		
				3.218	-	3.383		
			7634	3.366	3.4	3.434		
				3.315	-	3.485		
			7635	3.465	3.5	3.535		
				3.413	-	3.588		
			7636	3.564	3.6	3.636		
				3.510	-	3.690		
			7637	3.663	3.7	3.737		
				3.608	-	3.793		
			7638	3.762	3.8	3.838		
				3.705	-	3.895		
			7639	3.861	3.9	3.939		
				3.803	-	3.998		
			7640	3.960	4.0	4.040		
				3.900	-	4.100		
			7641	4.059	4.1	4.141		
				3.998	-	4.203		
			7642	4.158	4.2	4.242		
				4.095	-	4.305		
			7643	4.257	4.3	4.343		
				4.193	-	4.408		
			7644	4.356	4.4	4.444		
				4.290	-	4.510		
			7645	4.455	4.5	4.545		
				4.388	-	4.613		
			7646	4.554	4.6	4.646		
				4.485	-	4.715		
			7647	4.653	4.7	4.747		
				4.583	-	4.818		
			7648	4.752	4.8	4.848		
				4.680	-	4.920		
			7649	4.851	4.9	4.949		
				4.778	-	5.023		
			7650	4.950	5.0	5.050		
				4.875	-	5.125		
7651	5.049	5.1	5.151					
	4.973	-	5.228					
7652	5.148	5.2	5.252					
	5.070	-	5.330					
7653	5.247	5.3	5.353					
	5.168	-	5.433					

KIC7608~7660T5

Electrical characteristics (Unless Otherwise Specified Ta=25)

ITEM	SYMBOL	MEASUREMENT CONDITIONS	RANK	MIN.	TYP.	MAX.	UNITS	CIRCUIT					
Reset Threshold	V_{TH}	Ta = +25 Ta = -40~+85	7654	5.346	5.4	5.454	V	(2)					
				5.265	-	5.535							
			7655	5.445	5.5	5.555							
				5.363	-	5.638							
			7656	5.544	5.6	5.656							
				5.460	-	5.740							
			7657	5.643	5.7	5.757							
				5.558	-	5.843							
			7658	5.742	5.8	5.858							
				5.655	-	5.945							
			7659	5.841	5.9	5.959							
				5.753	-	6.048							
			7660	5.940	6.0	6.060							
				5.850	-	6.150							
			Reset Threshold hysteresis	V_{TH}	$V_{DD}=0V$ $V_{TH}+1V$ $0V$	7608			24	40	64	mV	(2)
						7609			27	45	72		
7610	30	50				80							
7611	33	55				88							
7612	36	60				96							
7613	39	65				104							
7614	42	70				112							
7615	45	75				120							
7616	48	80				128							
7617	51	85				136							
7618	54	90				144							
7619	57	95				152							
7620	60	100				160							
7621	63	105				168							
7622	66	110				176							
7623	69	115				184							
7624	72	120				192							
7625	75	125				200							
7626	78	130				208							
7627	81	135				216							
7628	84	140				224							
7629	87	145				232							
7630	90	150				240							
7631	93	155				248							
7632	96	160				256							
7633	99	165				264							
7634	102	170				272							
7635	105	175				280							
7636	108	180	288										
7637	111	185	296										
7638	114	190	304										
7639	117	195	312										
7640	120	200	320										

KIC7608~7660T5

ITEM	SYMBOL	MEASUREMENT CONDITIONS	RANK	MIN.	TYP.	MAX.	UNITS	CIRCUIT
Reset Threshold hysteresis	V_{TH}	$V_{DD}=0V \quad V_{TH}+1V \quad 0V$	7641	123	205	328	mV	(2)
			7642	126	210	336		
			7643	129	215	344		
			7644	132	220	352		
			7645	135	225	360		
			7646	138	230	368		
			7647	141	235	376		
			7648	144	240	384		
			7649	147	245	392		
			7650	150	250	400		
			7651	153	255	408		
			7652	156	260	416		
			7653	159	265	424		
			7654	162	270	432		
			7655	165	275	440		
			7656	168	280	448		
			7657	171	285	456		
7658	174	290	464					
7659	177	295	472					
7660	180	300	480					
Supply Current	I_{DD}	$V_{DD} = V_{TH} + 1V$	7608 ~7660	-	0.35	1.0	μA	(1)
Reset threshold temp. coefficient	$V_{TH}/$	$T_a = -40 \sim 85$	7608 ~7660	-	± 100	-	ppm/	(2)
" L "transfer delay time	t_{PHL}	$V_{DD}=V_{TH}+0.4V \quad V_{TH}-0.4V(\text{note})$	7608 ~7660	2	15	100	μs	(6)
" H "transfer delay time	t_{PLH}	$V_{DD}=V_{TH}-0.4V \quad V_{TH}+0.4V(\text{note})$	7608 ~7660	2	15	100	μs	(6)
" L "output current	I_{OL1}	$V_{DD}=0.7V, V_{DS}=0.05V$	7608 ~7660	0.01	0.10	-	mA	(3)
	I_{OL2}	$V_{DD}=1.2V, V_{DS}=0.5V, V_{TH} \quad 1.3V$	7608 ~7660	0.23	2.00	-		
	I_{OL3}	$V_{DD}=2.4V, V_{DS}=0.5V, V_{TH} \quad 2.5V$	7625 ~7660	1.60	8.00	-		
	I_{OL4}	$V_{DD}=3.6V, V_{DS}=0.5V, V_{TH} \quad 3.7V$	7637 ~7660	3.20	12.0	-		
Output leakage current	I_{leak}	$V_{DD}=10V, OUT=10V$	7608 ~7660	-	-	0.1	μA	(3)

Note) This parameter is guaranteed by design.

KIC7608~7660T5

ITEM	SYMBOL	TEST CONDITIONS	RANK	MIN.	TYP.	MAX.	UNITS	CIRCUIT
C _D pin resistance	R _D	-	7608 ~7660	9	10	11	M	(5)
C _D pin threshold voltage	V _{TCD}	V _{DD} = V _{TH} × 1.1V	7608 ~7660	V _{DD} × 0.3	V _{DD} × 0.5	V _{DD} × 0.7	V	(4)
C _D pin output current 1	I _{CD1}	V _{DS} = 0.1V V _{DD} = 0.7V	7608 ~7660	2.0	30.0	-	μA	(5)
C _D pin output current 2	I _{CD2}	V _{DS} = 0.5V V _{DD} = 0.8V(Rank08 ~ 10) V _{DD} = 1.0V(Rank11 ~ 15) V _{DD} = 1.5V(Rank16 ~ 60)	7608 ~7610	10	100	-	μA	(5)
			7611 ~7615	50	200	-		
			7616 ~7660	200	800	-		

Note) This device is tested at Ta=25 , over temperature limits guaranteed by design only

KIC7608~7660T5

Test circuits

(1)

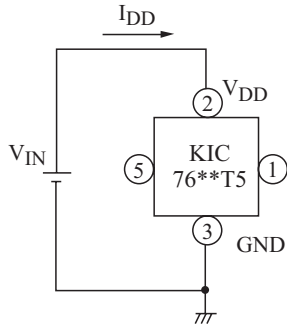

(2)

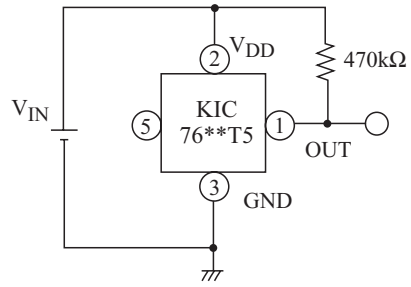

(3)

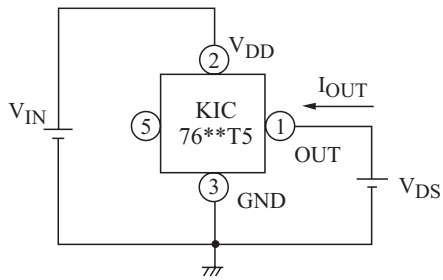

(4)

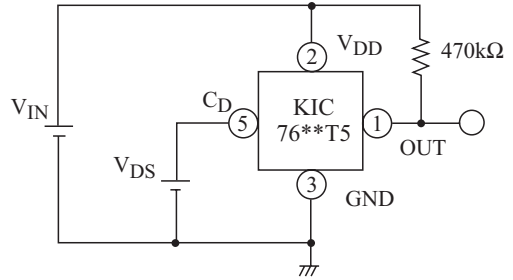

(5)

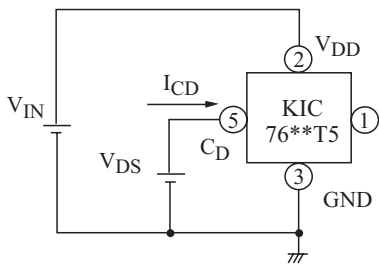

(6)

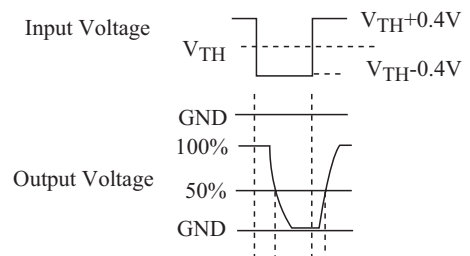
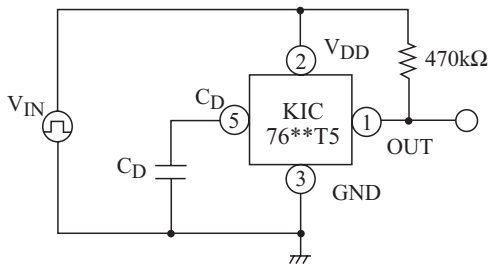

KIC7608~7660T5

Timing Chart

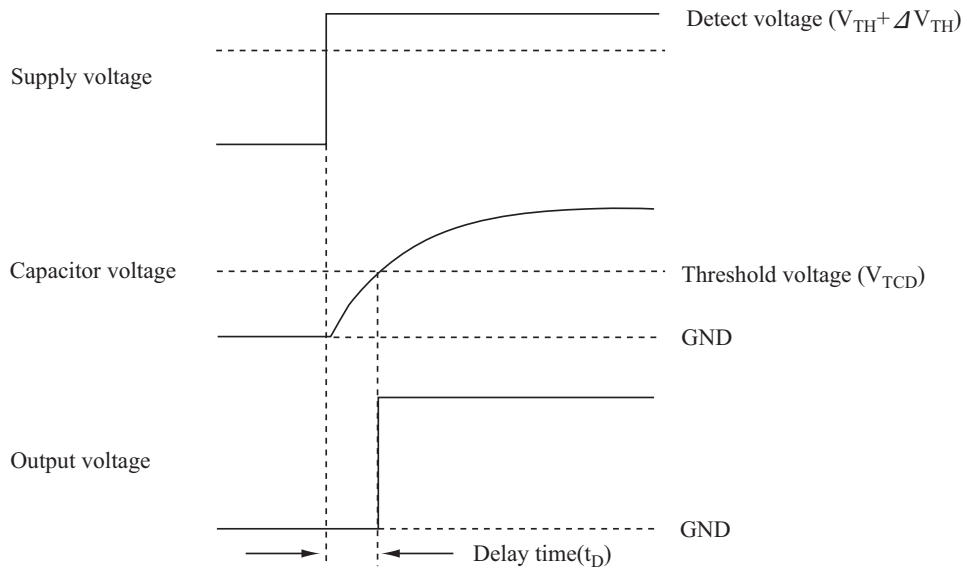

Delay time(t_D) $t_D \cong 0.69 \times R_D \times C_D$ (F) (s) R_D : C_D pin resistance
 C_D : Capacitor

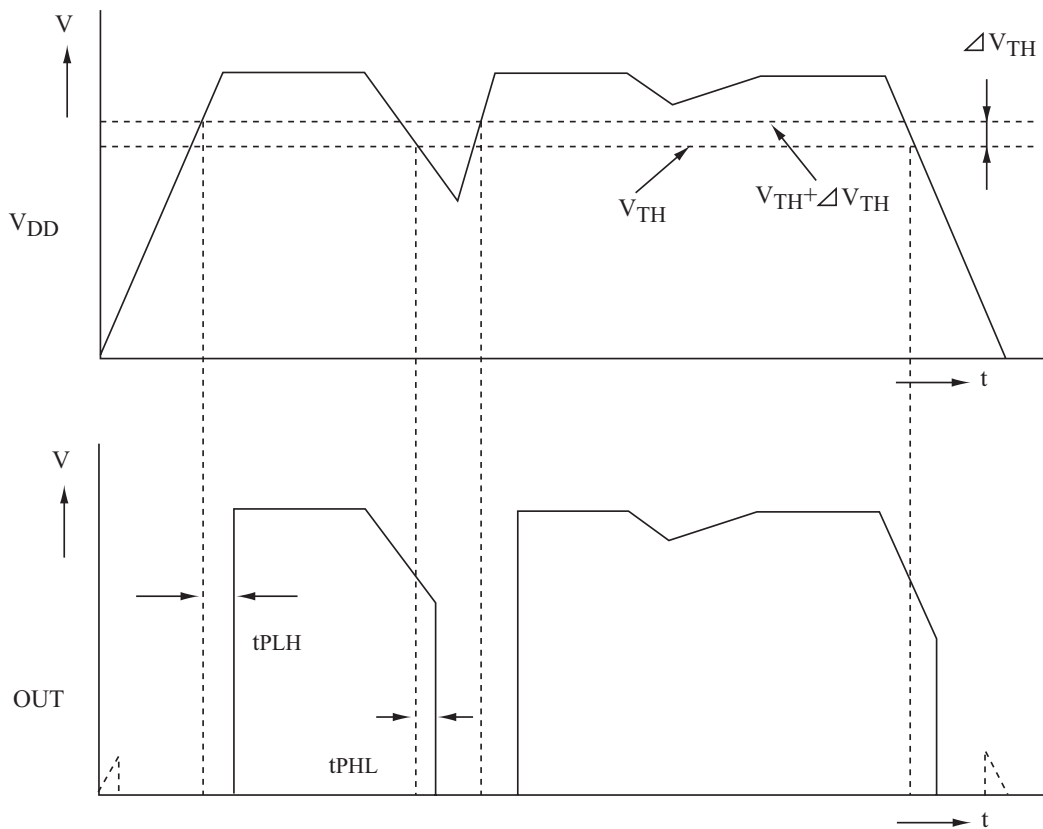

KIC7608~7660T5

Application Circuits

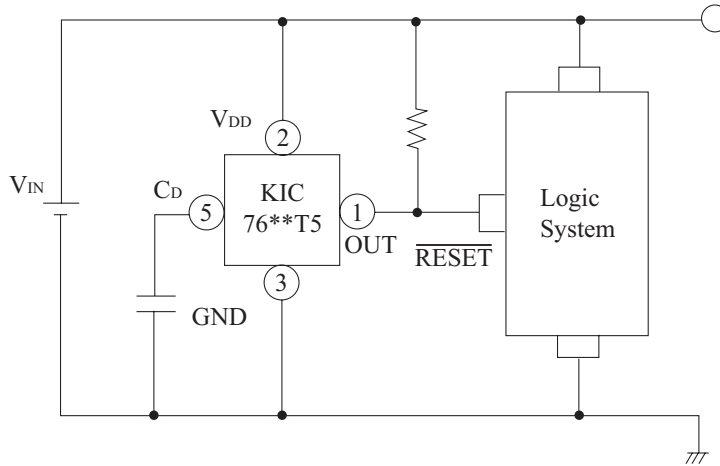

- We shall not be liable for any trouble or damage caused by using this circuit.
- In the event a problem which may affect industrial property or any other rights of us or a third party is encountered during the use of information described in these circuit, KEC shall not be liable for any such problem, nor grant a license therefore.

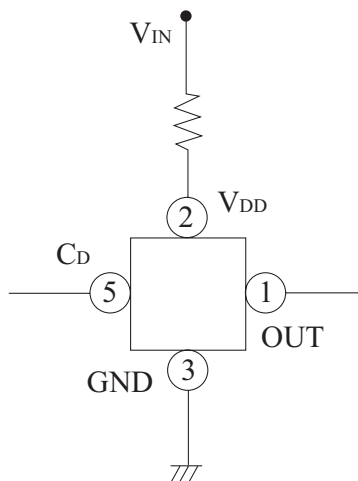

- Please note that there is any possibility of circuit oscillation when resistance put in the line V_{IN}.
- Recommend 15k or less for KIC76**T5.
- Since the C_D pin is a high impedance terminal of 10M. When using without connecting the delay capacitor, it may cause malfunction due to noise from outside.

KIC7608~7660T5

Typical Characteristics (Typical performance Characteristics 2.9V)

note : These are typical characteristics

Fig1. Detecting Voltage

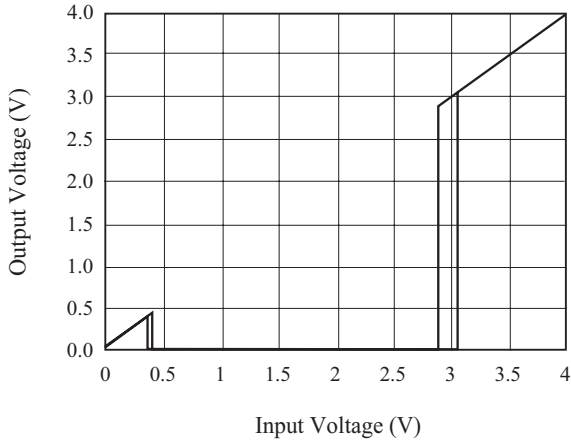

Fig2. Supply Current

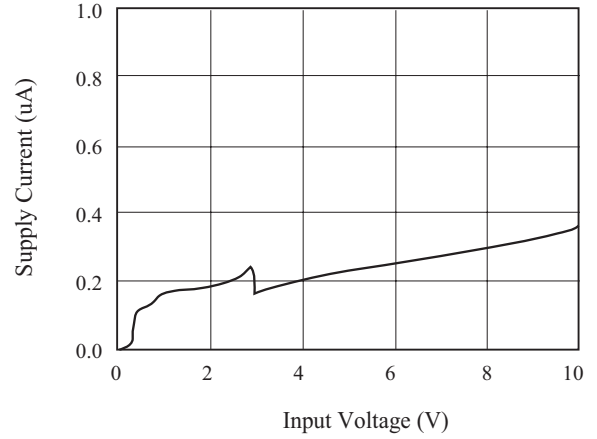

Fig3. C_D Pin Output Current

$V_{DS} = 0.5V$

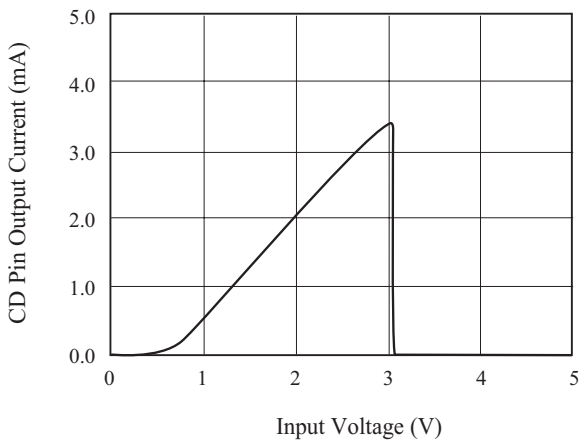

Fig4. Delay Time vs C_D

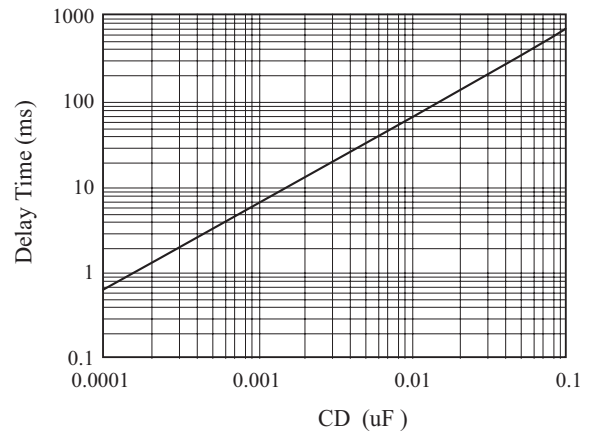

Fig5. Detecting Voltage vs Temperature

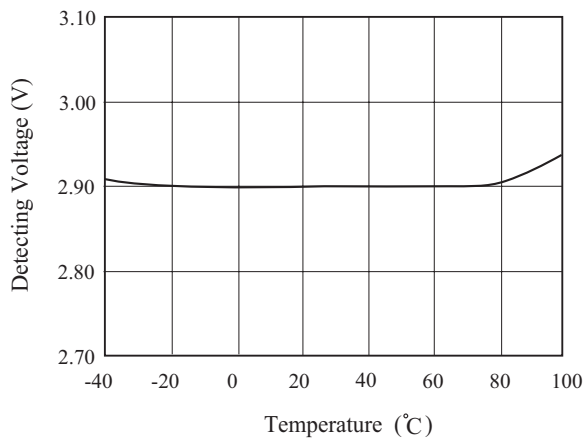
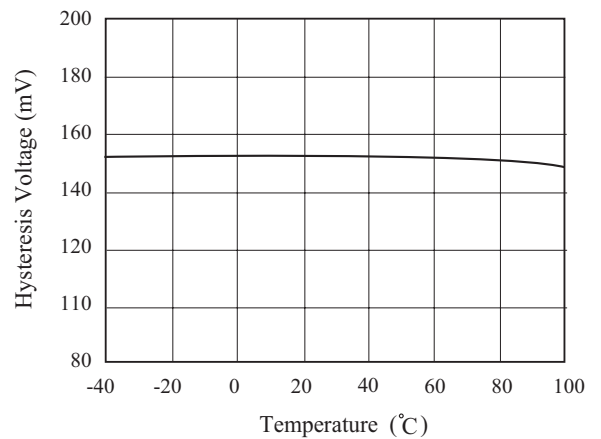

Fig6. Hysteresis Voltage vs Temperature



KIC7608~7660T5

Fig7. "L" Output Current 1 vs Temperature

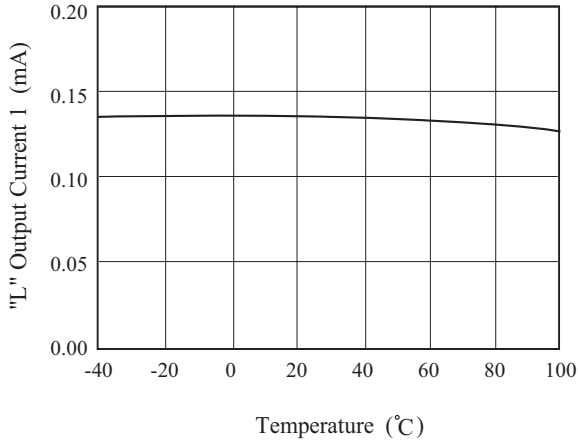

Fig8. "L" Output Current 2 vs Temperature

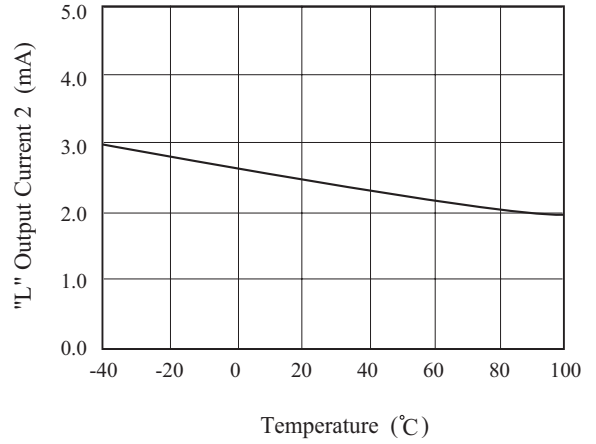

Fig9. "L" Output Current 3 vs Temperature

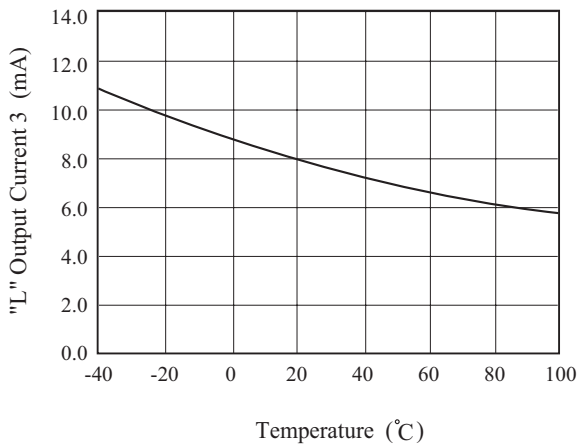

Fig10. C_D Pin Threshold Voltage vs Temperature

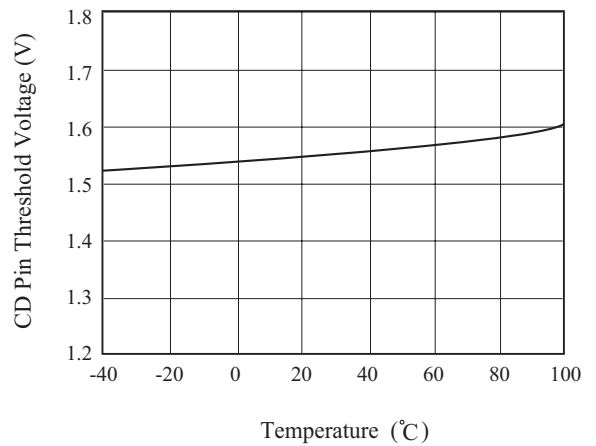

Fig11. C_D Pin Output Current 1 vs Temperature

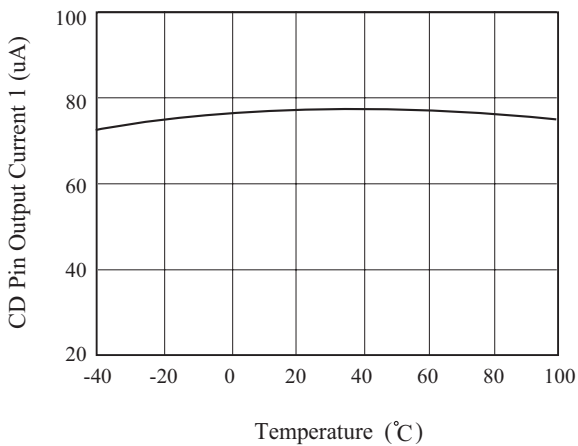
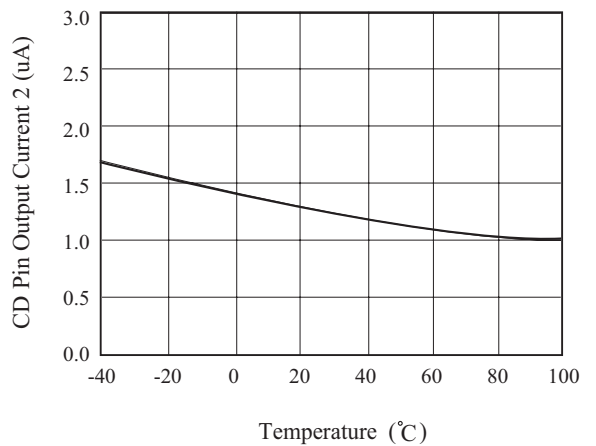
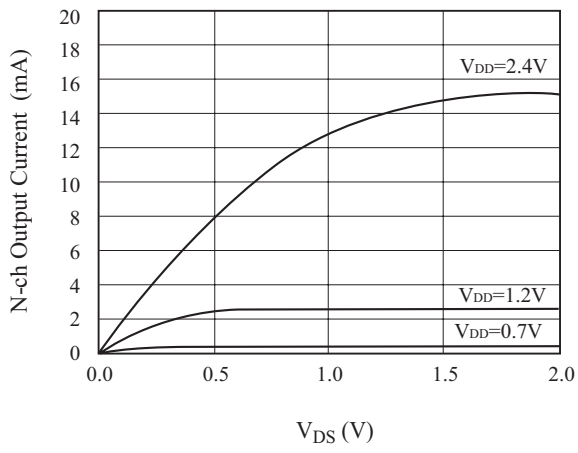

Fig12. C_D Pin Output Current 2 vs Temperature



KIC7608~7660T5

Fig13. N-ch Output Current



➔
magnify

