

HIGH VOLTAGE APPLICATION.

### FEATURE

- Complementary to KTC1027.

### MAXIMUM RATING (Ta=25°C)

CHARACTERISTIC	SYMBOL	RATING	UNIT
Collector-Base Voltage	$V_{CBO}$	-120	V
Collector-Emitter Voltage	$V_{CEO}$	-120	V
Emitter-Base Voltage	$V_{EBO}$	-5	V
Collector Current	$I_C$	-800	mA
Emitter Current	$I_E$	800	mA
Collector Power Dissipation	$P_C$	1	W
Junction Temperature	$T_j$	150	°C
Storage Temperature Range	$T_{stg}$	-55 ~ 150	°C

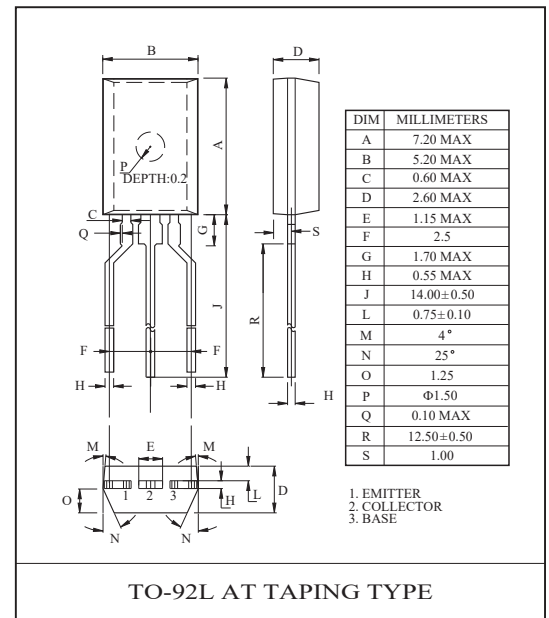
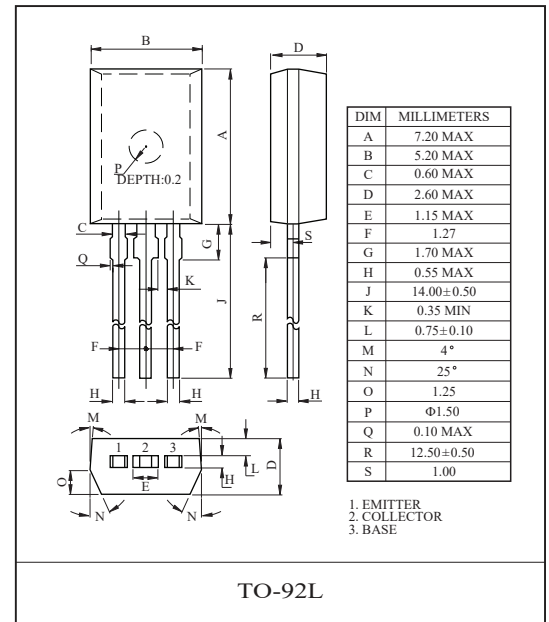

### ELECTRICAL CHARACTERISTICS (Ta=25°C)

CHARACTERISTIC	SYMBOL	TEST CONDITION	MIN.	TYP.	MAX.	UNIT
Collector Cut-off Current	$I_{CBO}$	$V_{CB}=-120V, I_E=0$	-	-	-100	nA
Emitter Cut-off Current	$I_{EBO}$	$V_{EB}=-5V, I_C=0$	-	-	-100	nA
Collector-Emitter Saturation Voltage	$V_{(BR)CEO}$	$I_C=-10mA, I_B=0$	-120	-	-	V
Emitter-Base Breakdown Voltage	$V_{(BR)EBO}$	$I_E=-1mA, I_C=0$	-5	-	-	V
DC Current Gain	$h_{FE}(\text{Note})$	$V_{CE}=-5V, I_C=-100mA$	80	-	240	
Collector-Emitter Saturation Voltage	$V_{CE(sat)}$	$I_C=-500mA, I_B=-50mA$	-	-	-1.0	V
Base-Emitter Voltage	$V_{BE}$	$V_{CE}=-5V, I_C=-500mA$	-	-	-1.0	V
Transition Frequency	$f_T$	$V_{CE}=-5V, I_C=-100mA$	-	120	-	MHz
Collector Output Capacitance	$C_{ob}$	$V_{CB}=-10V, I_E=0, f=1MHz$	-	-	40	pF

Note :  $h_{FE}$  Classification O:80 ~ 160, Y:120 ~ 240

$I_C - V_{CE}$

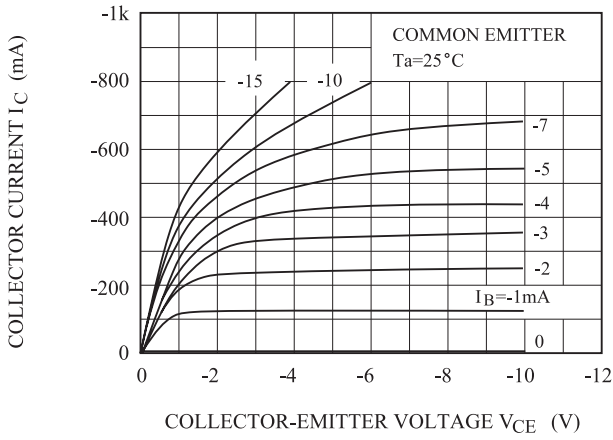

$h_{FE} - I_C$

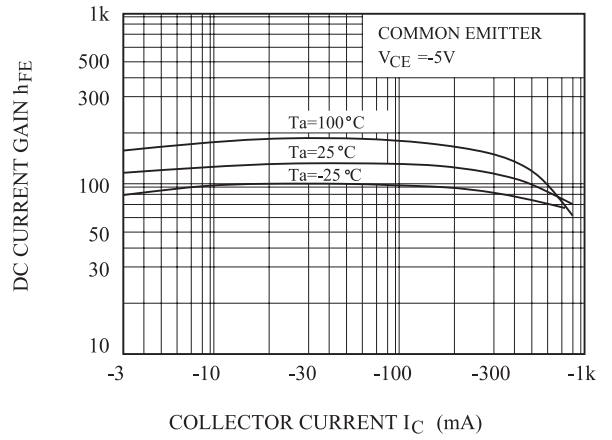

$V_{CE(sat)} - I_C$

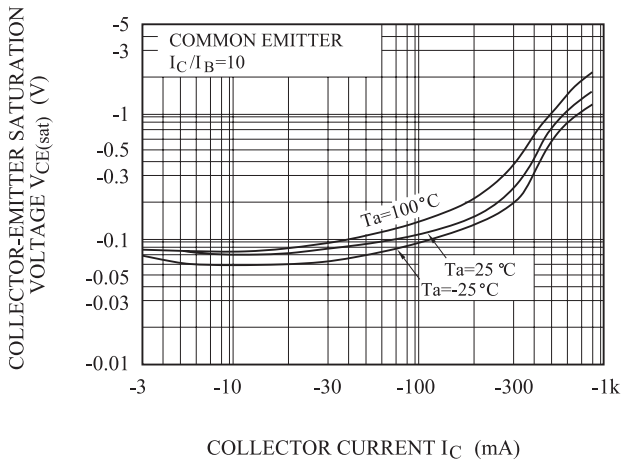

$I_C - V_{BE}$

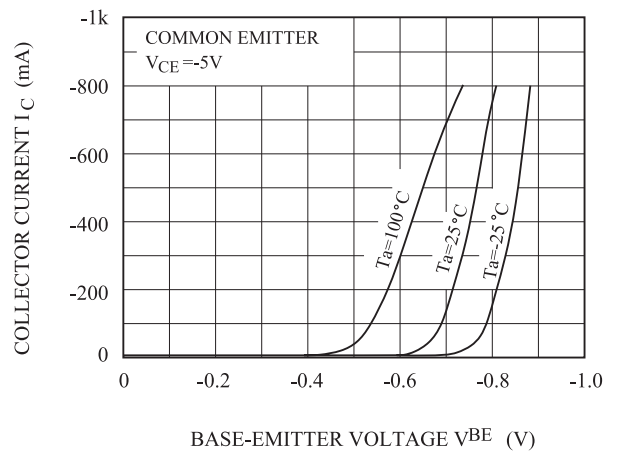

$P_c - T_a$

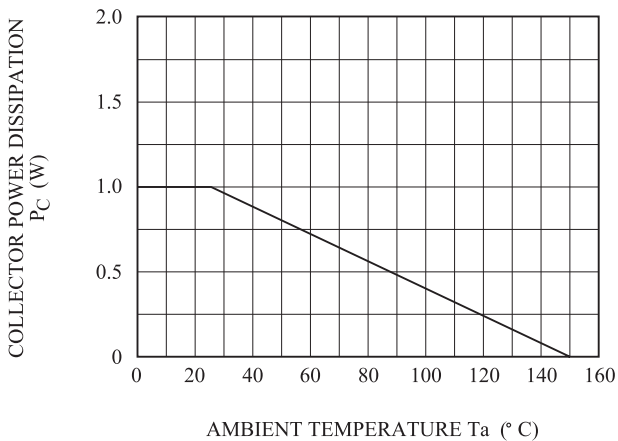

SAFE OPERATING AREA

