

HIGH VOLTAGE APPLICATION.

FEATURE

- Complementary to KTA1023.

MAXIMUM RATING (Ta=25°C)

CHARACTERISTIC	SYMBOL	RATING	UNIT
Collector-Base Voltage	V_{CBO}	120	V
Collector-Emitter Voltage	V_{CEO}	120	V
Emitter-Base Voltage	V_{EBO}	5	V
Collector Current	I_C	800	mA
Emitter Current	I_E	-800	mA
Collector Power Dissipation	P_C	1	W
Junction Temperature	T_j	150	°C
Storage Temperature Range	T_{stg}	-55 ~ 150	°C

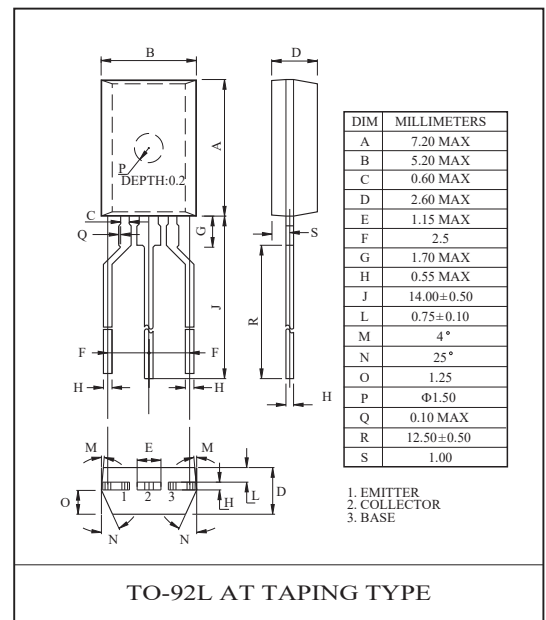
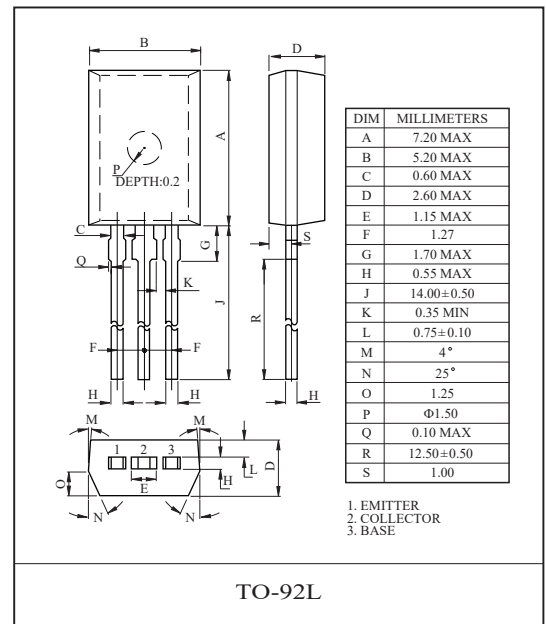

ELECTRICAL CHARACTERISTICS (Ta=25°C)

CHARACTERISTIC	SYMBOL	TEST CONDITION	MIN.	TYP.	MAX.	UNIT
Collector Cut-off Current	I_{CBO}	$V_{CB}=120V, I_E=0$	-	-	100	nA
Emitter Cut-off Current	I_{EBO}	$V_{EB}=5V, I_C=0$	-	-	100	nA
Collector-Emitter Breakdown Voltage	$V_{(BR)CEO}$	$I_C=10mA, I_B=0$	120	-	-	V
Emitter-Base Breakdown Voltage	$V_{(BR)EBO}$	$I_E=1mA, I_C=0$	5.0	-	-	V
DC Current Gain	h_{FE} (Note)	$V_{CE}=5V, I_C=100mA$	80	-	240	
Collector-Emitter Saturation Voltage	$V_{CE(sat)}$	$I_C=500mA, I_B=50mA$	-	-	1.0	V
Base-Emitter Voltage	V_{BE}	$V_{CE}=5V, I_C=500mA$	-	-	1.0	V
Transition Frequency	f_T	$V_{CE}=5V, I_C=100mA$	-	120	-	MHz
Collector Output Capacitance	C_{ob}	$V_{CB}=10V, I_E=0, f=1MHz$	-	-	30	pF

Note : h_{FE} Classification O:80 ~ 160, Y:120 ~ 240

