

IC for CMOS Detector Monolithic IC KIC75** Series

This IC functions in a variety of CPU systems and other logic systems, to detect supply voltage and reset the system accurately when the power is turned on or interrupted.

To 2% of detection voltage accuracy of the conventional models, a maximum of 1% of super-high precision is realized, and it is more suitable for battery detection etc.

FEATURES

- High Accuracy : $\pm 1\%$
- Ultra-low current consumption: 0.25 μA (Typ)
- Operating temperature range : $-40\sim +105$
- Detecting voltage rank : 0.8 ~ 6.0V(0.1V step)
- Output configuration : Open drain output
- Suffix U : Qualified to AEC-Q100
ex) KIC75xxM-RTK/HU

Applications

- Reset circuits for microcomputers, CPUs and MPUs
- Reset circuits for logic circuits
- Battery voltage check circuits
- Back-up power supply switching circuits
- Level detection circuits

Pin Configuration

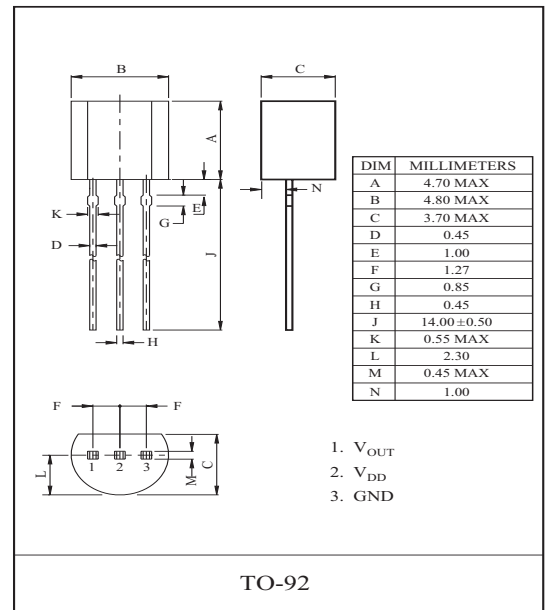
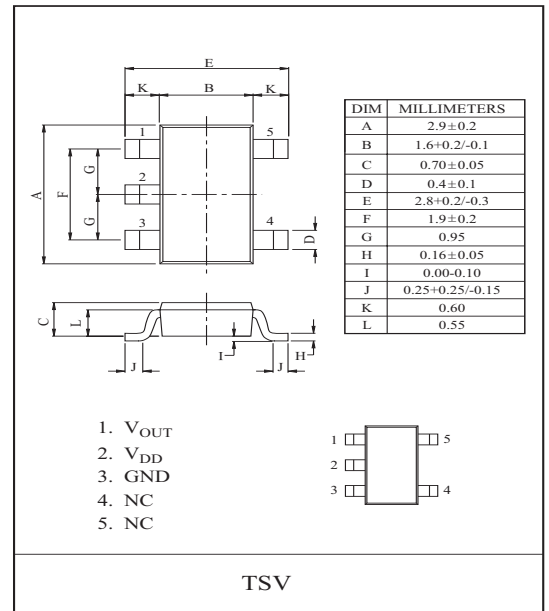
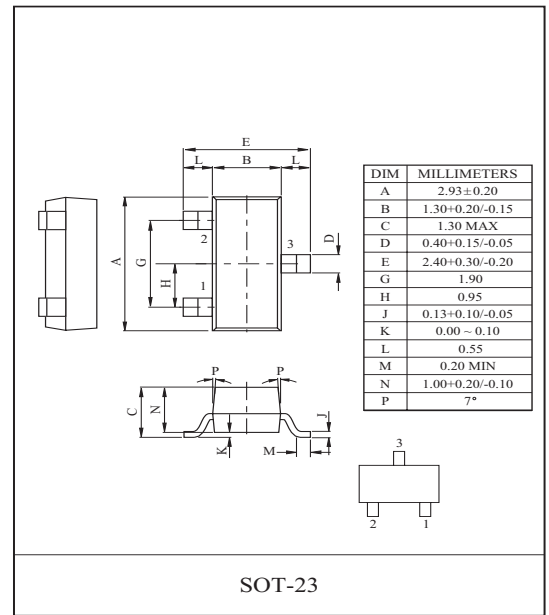
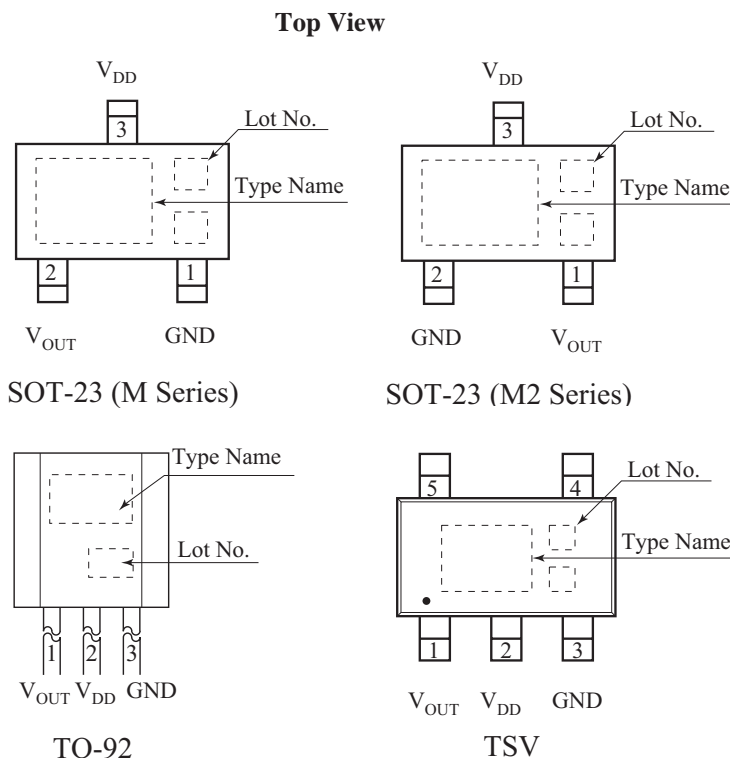

KIC7508~7560M/M2/T5/P

Block Diagram

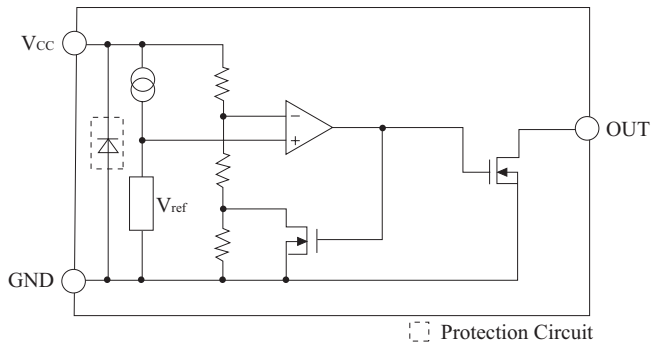

Figure. 1

Pin No				Symbol	Function
SOT-23		TSV	TO-92		
M	M2				
1	2	3	3	GND	GND
2	1	1	1	V _{OUT}	Detector Output
3	3	2	2	V _{DD}	Power Supply Voltage
-	-	4.5	-	NC	No Connection.

Selection Guide

The output voltage, package type for the ICs can be selected at the user's request. The selection can be made with designating the part number as shown below

KIC7 5 _____

NO.	Specifications	Description
	Voltage Detector Code	-
	Detection Voltage	0.8 ~ 6.0V
	Package	M/M2 SOT - 23
		T5 TSV
		P TO-92

KIC7508~7560M/M2/T5/P

Line-up

Detection voltage	SOT-23 / TSV		TO-92	Detection voltage	SOT-23 / TSV		TO-92
	Item	Marking	Item		Item	Marking	Item
0.8V	KIC7508M/T5	508	KIC7508P	3.5V	KIC7535M/T5	535	KIC7535P
0.9V	KIC7509M/T5	509	KIC7509P	3.6V	KIC7536M/T5	536	KIC7536P
1.0V	KIC7510M/T5	510	KIC7510P	3.7V	KIC7537M/T5	537	KIC7537P
1.1V	KIC7511M/T5	511	KIC7511P	3.8V	KIC7538M/T5	538	KIC7538P
1.2V	KIC7512M/T5	512	KIC7512P	3.9V	KIC7539M/T5	539	KIC7539P
1.3V	KIC7513M/T5	513	KIC7513P	4.0V	KIC7540M/T5	540	KIC7540P
1.4V	KIC7514M/T5	514	KIC7514P	4.1V	KIC7541M/T5	541	KIC7541P
1.5V	KIC7515M/T5	515	KIC7515P	4.2V	KIC7542M/T5	542	KIC7542P
1.6V	KIC7516M/T5	516	KIC7516P	4.3V	KIC7543M/T5	543	KIC7543P
1.7V	KIC7517M/T5	517	KIC7517P	4.4V	KIC7544M/T5	544	KIC7544P
1.8V	KIC7518M/T5	518	KIC7518P	4.5V	KIC7545M/T5	545	KIC7545P
1.9V	KIC7519M/T5	519	KIC7519P	4.6V	KIC7546M/T5	546	KIC7546P
2.0V	KIC7520M/T5	520	KIC7520P	4.7V	KIC7547M/T5	547	KIC7547P
2.1V	KIC7521M/T5	521	KIC7521P	4.8V	KIC7548M/T5	548	KIC7548P
2.2V	KIC7522M/T5	522	KIC7522P	4.9V	KIC7549M/T5	549	KIC7549P
2.3V	KIC7523M/T5	523	KIC7523P	5.0V	KIC7550M/T5	550	KIC7550P
2.4V	KIC7524M/T5	524	KIC7524P	5.1V	KIC7551M/T5	551	KIC7551P
2.5V	KIC7525M/T5	525	KIC7525P	5.2V	KIC7552M/T5	552	KIC7552P
2.6V	KIC7526M/T5	526	KIC7526P	5.3V	KIC7553M/T5	553	KIC7553P
2.7V	KIC7527M/T5	527	KIC7527P	5.4V	KIC7554M/T5	554	KIC7554P
2.8V	KIC7528M/T5	528	KIC7528P	5.5V	KIC7555M/T5	555	KIC7555P
2.9V	KIC7529M/T5	529	KIC7529P	5.6V	KIC7556M/T5	556	KIC7556P
3.0V	KIC7530M/T5	530	KIC7530P	5.7V	KIC7557M/T5	557	KIC7557P
3.1V	KIC7531M/T5	531	KIC7531P	5.8V	KIC7558M/T5	558	KIC7558P
3.2V	KIC7532M/T5	532	KIC7532P	5.9V	KIC7559M/T5	559	KIC7559P
3.3V	KIC7533M/T5	533	KIC7533P	6.0V	KIC7560M/T5	560	KIC7560P
3.4V	KIC7534M/T5	534	KIC7534P				

KIC7508~7560M/M2/T5/P

Line-up-2

Detection voltage	SOT-23 / TSV		Detection voltage	SOT-23 / TSV	
	Item	Marking		Item	Marking
0.8V	KIC7508M2	G08	3.5V	KIC7535M2	G35
0.9V	KIC7509M2	G09	3.6V	KIC7536M2	G36
1.0V	KIC7510M2	G10	3.7V	KIC7537M2	G37
1.1V	KIC7511M2	G11	3.8V	KIC7538M2	G38
1.2V	KIC7512M2	G12	3.9V	KIC7539M2	G39
1.3V	KIC7513M2	G13	4.0V	KIC7540M2	G40
1.4V	KIC7514M2	G14	4.1V	KIC7541M2	G41
1.5V	KIC7515M2	G15	4.2V	KIC7542M2	G42
1.6V	KIC7516M2	G16	4.3V	KIC7543M2	G43
1.7V	KIC7517M2	G17	4.4V	KIC7544M2	G44
1.8V	KIC7518M2	G18	4.5V	KIC7545M2	G45
1.9V	KIC7519M2	G19	4.6V	KIC7546M2	G46
2.0V	KIC7520M2	G20	4.7V	KIC7547M2	G47
2.1V	KIC7521M2	G21	4.8V	KIC7548M2	G48
2.2V	KIC7522M2	G22	4.9V	KIC7549M2	G49
2.3V	KIC7523M2	G23	5.0V	KIC7550M2	G50
2.4V	KIC7524M2	G24	5.1V	KIC7551M2	G51
2.5V	KIC7525M2	G25	5.2V	KIC7552M2	G52
2.6V	KIC7526M2	G26	5.3V	KIC7553M2	G53
2.7V	KIC7527M2	G27	5.4V	KIC7554M2	G54
2.8V	KIC7528M2	G28	5.5V	KIC7555M2	G55
2.9V	KIC7529M2	G29	5.6V	KIC7556M2	G56
3.0V	KIC7530M2	G30	5.7V	KIC7557M2	G57
3.1V	KIC7531M2	G31	5.8V	KIC7558M2	G58
3.2V	KIC7532M2	G32	5.9V	KIC7559M2	G59
3.3V	KIC7533M2	G33	6.0V	KIC7560M2	G60
3.4V	KIC7534M2	G34			

KIC7508~7560M/M2/T5/P

ABSOLUTE MAXIMUM RATINGS (Ta=25)

ITEM	SYMBOL	RATING		UNITS
Supply voltage	$V_{DD\ MAX}$	-0.3 +12.0		V
Output voltage	V_{OUT}	-0.3 ($V_{DD}+0.3$)		V
Input current (V_{DD})	I_{DD}	20		mA
Output current (\overline{RESET})	I_{OUT}	20		mA
Power Dissipation	P_D	SOT-23	350 * Note 1)	mW
		TSV	900 * Note 2)	
		TO-92	400	
Operating Junction Temperature	T_j	-40~+150		
Operating temperature	T_{OPR}	-40~+105		
Storage temperature	T_{STG}	-65~+150		

* Note 1) Package Mounted on 99.5% Alumina (10 × 8 × 0.6mm)

* Note 2) Package Mounted on a Ceramic board (600mm² × 0.8mm)

Recommended Operating Conditions

ITEM	SYMBOL	RATINGS	UNITS
Operating Temperature	T_{opr}	-40 +105	
Supply voltage	V_{DD}	0.70 ~ 10.0	V

Electrical characteristics : Unless Otherwise Specified Ta=25

ITEM	SYMBOL	MEASUREMENT CONDITIONS	MIN.	TYP.	MAX.	UNITS	CIRCUIT
Supply current	I_{DD}	$V_{DD} = V_{TH} + 1V$	-	0.25	1.0	uA	(1)
Reset threshold	V_{TH}	Ta = +25	$V_{TH}-1\%$	V_{TH} 0.8~6.0V (0.1Vstep)	$V_{TH}+1\%$	V	(2)
		Ta = -40~+85 (note1)	$V_{TH}-2.5\%$		$V_{TH}+2.5\%$		
Reset threshold hysteresis	V_{TH}	$V_{DD}=0V$ $V_{TH}+1V$ $0V$	$V_{TH} \times 0.03$	-	$V_{TH} \times 0.08$	V	(2)
Reset threshold temp. coefficient	$V_{TH}/$	Ta=-40~+85 (note 1)	-	± 100	-	ppm/	(2)
L transfer delay time	t_{PHL}	$V_{DD}=V_{TH}+0.4V$ $V_{TH}-0.4V$ (note 2)	-	-	100	us	(4)
H transfer delay time	t_{PLH}	$V_{DD}=V_{TH}+0.4V$ $V_{TH}-0.4V$ (note 2)	-	-	100	us	(4)
"L" output current	I_{OL1}	$V_{DD}=0.7V$, $V_{DS}=0.05V$	0.01	0.10	-	mA	(3)
	I_{OL2}	$V_{DD}=1.2V$, $V_{DS}=0.5V$ $V_{TH} 1.3V$	0.23	2.00			
	I_{OL3}	$V_{DD}=2.4V$, $V_{DS}=0.5V$ $V_{TH} 2.5V$	1.60	8.00			
	I_{OL4}	$V_{DD}=3.6V$, $V_{DS}=0.5V$ $V_{TH} 3.7V$	3.20	12.0			
Output leakage current	I_{LEAK}	$V_{DD}=10V$, $V_{OUT}=10V$	-	-	0.1	uA	(3)

note 1: This device is tested at Ta=25 , over temperature limits guaranteed by design only.

note 2: The parameter is guaranteed by design.

KIC7508~7560M/M2/T5/P

Test Circuits

(1) I_{DD}

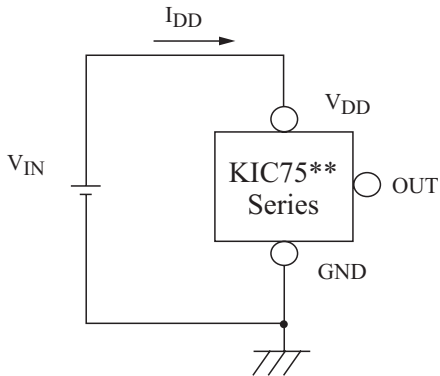

(2) V_{TH} , ΔV_{TH} , $\Delta V_{TH}/^{\circ}C$

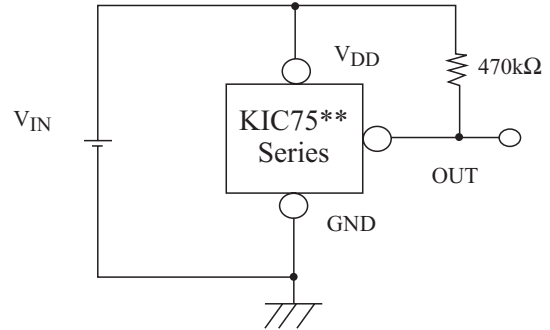

(3) I_{OL1} , I_{OL2} , I_{OL3} , I_{OL4} , I_{LEAK}

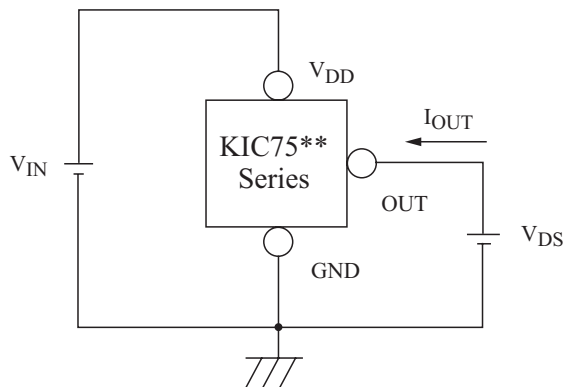

(4) t_{PLH} , t_{PHL}

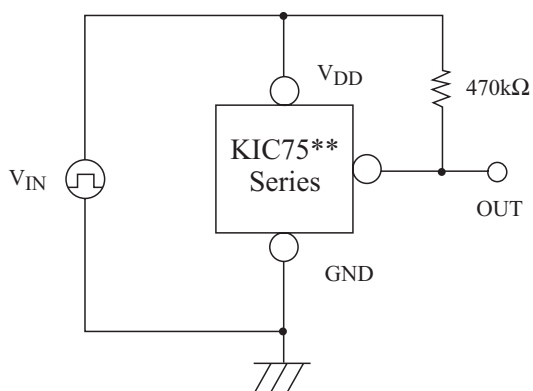

Test Wave

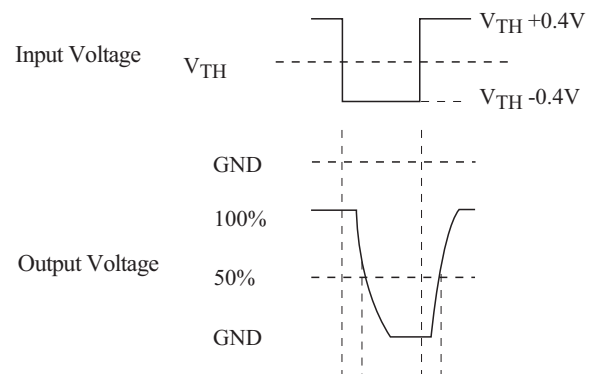

KIC7508~7560M/M2/T5/P

Application Circuits

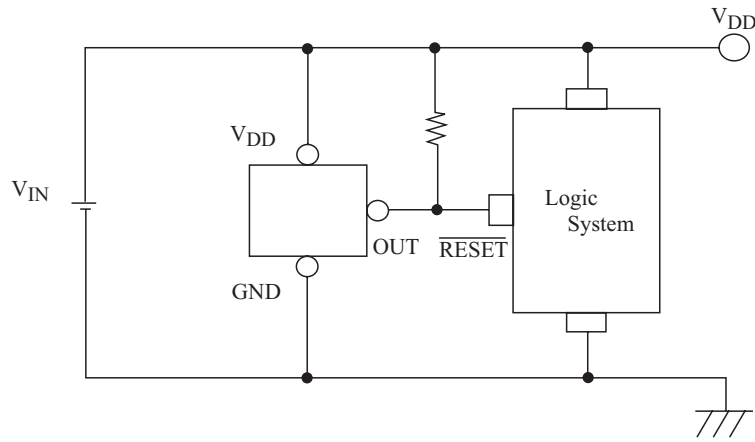

- We shall not be liable for any trouble or damage caused by using this circuit.
- In the event a problem which may affect industrial property or any other rights of us or a third party is encountered during the use of information described in these circuits, KEC shall not be liable for any such problem, nor grant a license therefore.

KIC7508~7560M/M2/T5/P

Typical Characteristics (Typical Performance Characteristics 2.8V)

note : These are typical characteristics

Fig1. Detecting Voltage

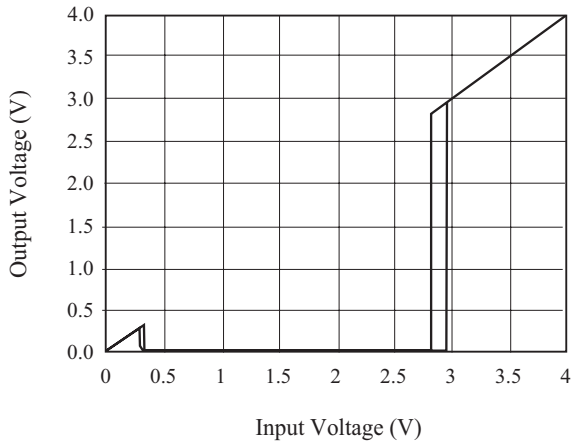

Fig2. Supply Current

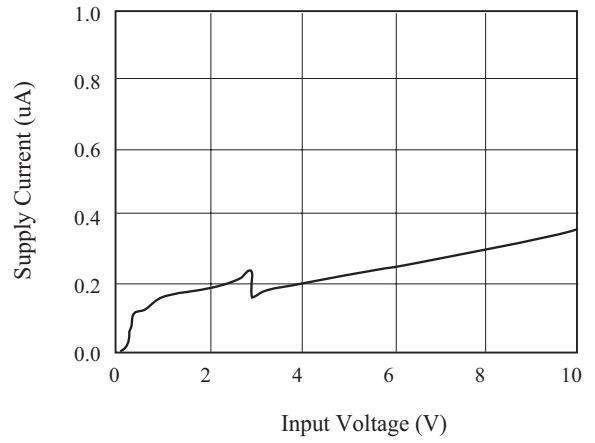

Fig3. Detecting Voltage vs Temperature

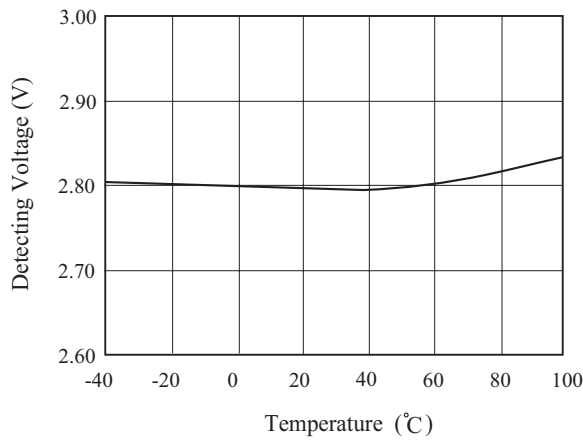

Fig4. Hysteresis Voltage vs Temperature

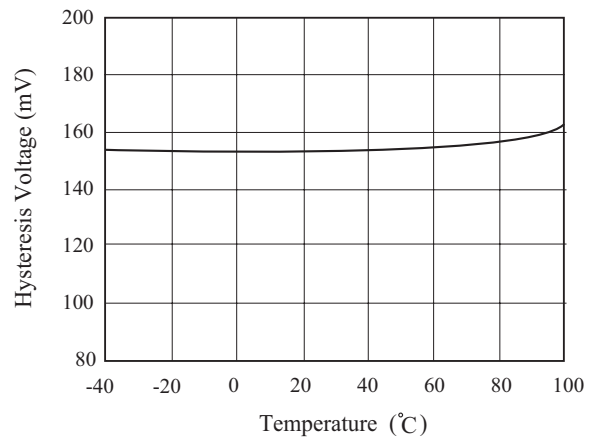

Fig5. "L" Output Current 1 vs Temperature

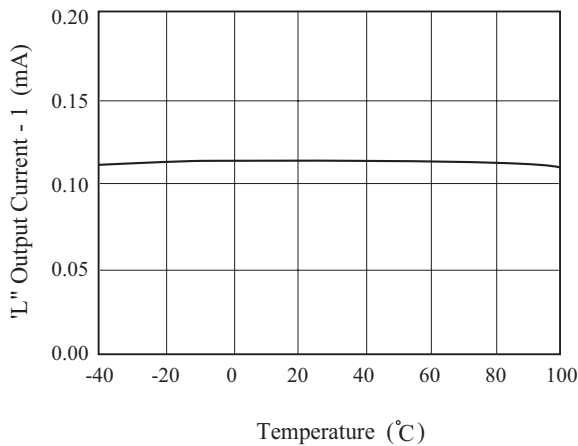

Fig6. "L" Output Current 2 vs Temperature

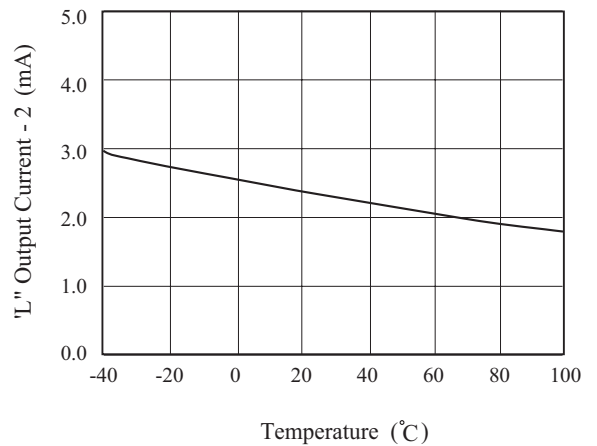

Fig7. "L" Output Current 3 vs Temperature

