

GENERAL PURPOSE APPLICATION.
SWITCHING APPLICATION.

· Complementary to KN4402/4403.

MAXIMUM RATING (Ta=25°C)

CHARACTERISTIC	SYMBOL	RATING	UNIT
Collector-Base Voltage	V_{CBO}	60	V
Collector-Emitter Voltage	V_{CEO}	40	V
Emitter-Base Voltage	V_{EBO}	6	V
Collector Current	I_C	600	mA
Collector Power Dissipation	P_C	625	mW
Junction Temperature	T_j	150	°C
Storage Temperature Range	T_{stg}	-55 ~ 150	°C

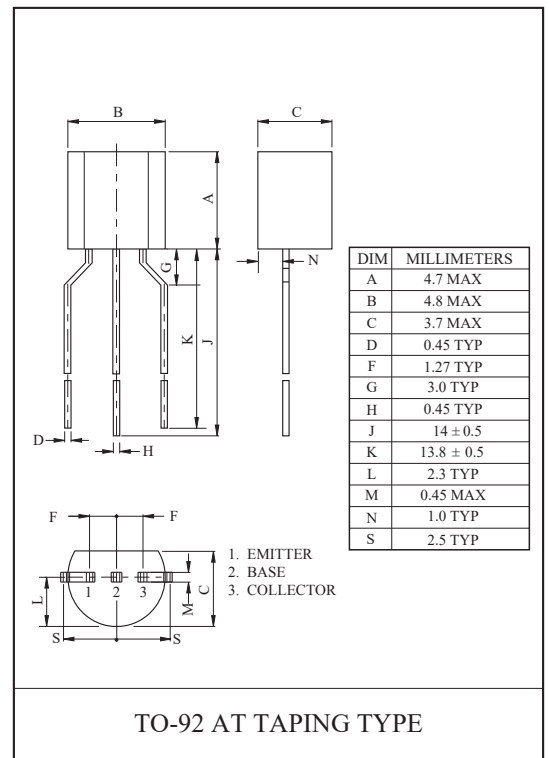
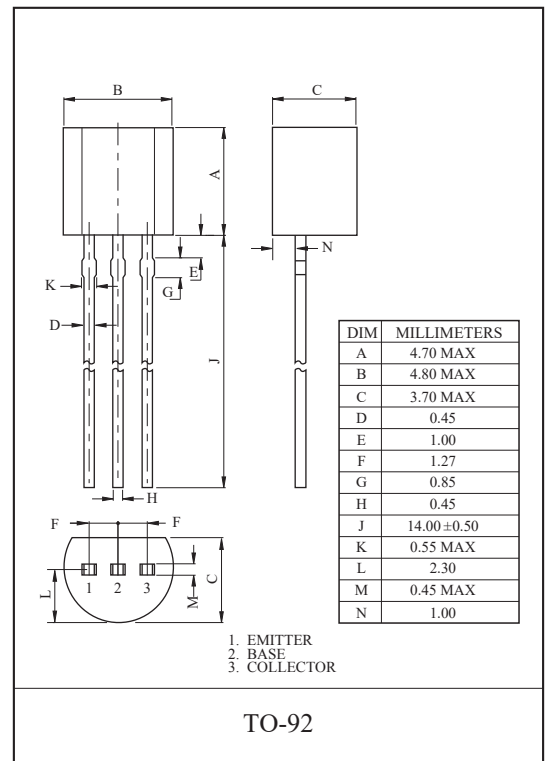

KN4400/4401

ELECTRICAL CHARACTERISTICS (Ta=25°C)

CHARACTERISTIC		SYMBOL	TEST CONDITION	MIN.	TYP.	MAX.	UNIT
Collector Cut-off Current		I_{CEX}	$V_{CE}=35V, V_{EB(OFF)}=0.4V$	-	-	100	nA
Collector Cut-off Current		I_{CBO}	$V_{CB}=60V, I_E=0$	-	-	100	nA
Emitter Cut-off Current		I_{EBO}	$V_{EB}=6V, I_C=0$	-	-	100	nA
Collector-Base Breakdown Voltage		$V_{(BR)CBO}$	$I_C=100\mu A, I_E=0$	60	-	-	V
Collector-Emitter Breakdown Voltage *		$V_{(BR)CEO}$	$I_E=1mA, I_B=0$	40	-	-	V
Emitter-Base Breakdown Voltage		$V_{(BR)EBO}$	$I_E=100\mu A, I_C=0$	6	-	-	V
DC Current Gain *	KN4401	$h_{FE(1)}$	$V_{CE}=1V, I_C=0.1mA$	20	-	-	
	KN4400	$h_{FE(1)}$	$V_{CE}=1V, I_C=1mA$	20	-	-	
	KN4401	$h_{FE(2)}$		40	-	-	
	KN4400	$h_{FE(2)}$	$V_{CE}=1V, I_C=10mA$	40	-	-	
	KN4401	$h_{FE(3)}$		80	-	-	
	KN4400	$h_{FE(3)}$	$V_{CE}=1V, I_C=150mA$	50	-	150	
	KN4401	$h_{FE(4)}$		100	-	300	
	KN4400	$h_{FE(4)}$	$V_{CE}=2V, I_C=500mA$	20	-	-	
	KN4401	$h_{FE(5)}$		40	-	-	
Collector-Emitter Saturation Voltage *		$V_{CE(sat)1}$	$I_C=150mA, I_B=15mA$	-	-	0.4	V
		$V_{CE(sat)2}$	$I_C=500mA, I_B=50mA$	-	-	0.75	
Base-Emitter Saturation Voltage *		$V_{BE(sat)1}$	$I_C=150mA, I_B=15mA$	0.75	-	0.95	V
		$V_{BE(sat)2}$	$I_C=500mA, I_B=50mA$	-	-	1.2	
Transition Frequency	KN4400	f_T	$I_C=20mA, V_{CE}=10V, f=100MHz$	200	-	-	MHz
	KN4401			250	-	-	
Collector Output Capacitance		C_{ob}	$V_{CB}=5V, I_E=0, f=1.0MHz$	-	-	6.5	pF

* Pulse Test : Pulse Width $\leq 300\mu s$, Duty Cycle $\leq 2\%$.

KN4400/4401

$h_{FE} - I_C$

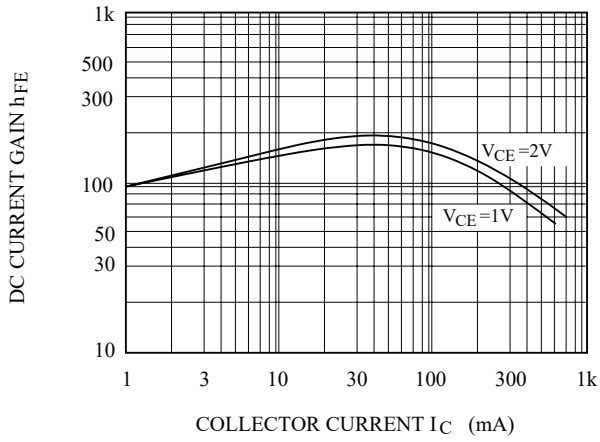

$C_{cb}, C_{ob} - V_{CB}$

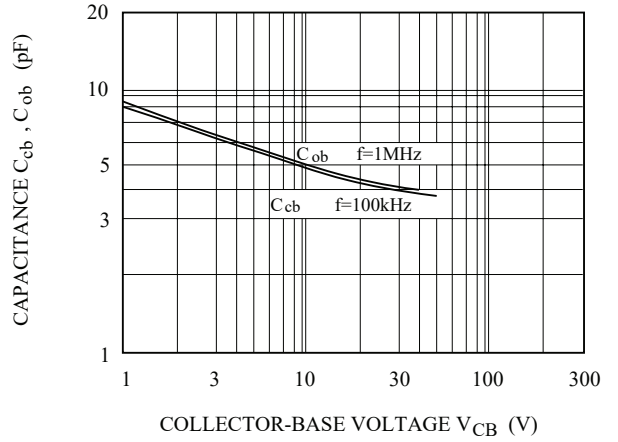

$V_{BE(sat)}, V_{CE(sat)} - I_C$

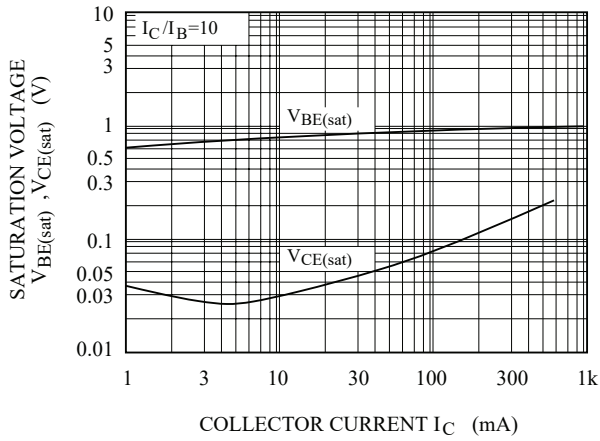

$P_C - T_a$

