

VOLTAGE REGULATORS, RELAY DRIVERS
LAMP DRIVERS, ELECTRICAL EQUIPMENT

FEATURES

- Adoption of MBIT processes.
- Low collector-to-emitter saturation voltage.
- Fast switching speed.
- Large current capacity and wide ASO.
- Complementary to KTD1347.

MAXIMUM RATING (Ta=25 °C)

CHARACTERISTIC	SYMBOL	RATING	UNIT
Collector-Base Voltage	V_{CBO}	-60	V
Collector-Emitter Voltage	V_{CEO}	-50	V
Emitter-Base Voltage	V_{EBO}	-6	V
Collector Current	I_C	-3	A
Collector Current (Pulse)	I_{CP}	-6	A
Collector Power Dissipation	P_C	1	W
Junction Temperature	T_j	150	°C
Storage Temperature Range	T_{stg}	-55 ~ 150	°C

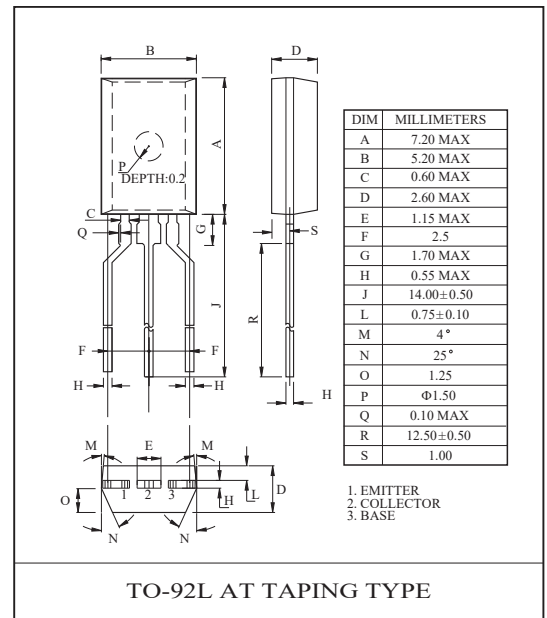
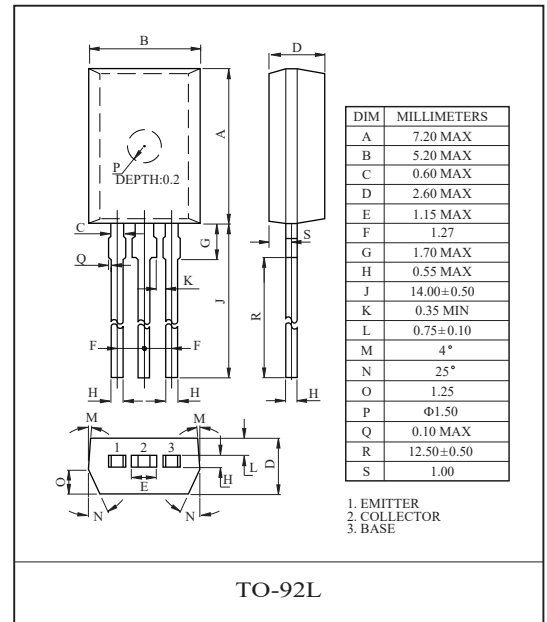

ELECTRICAL CHARACTERISTICS (Ta=25 °C)

CHARACTERISTIC		SYMBOL	TEST CONDITION	MIN.	TYP.	MAX.	UNIT.
Collector Cut-off Current		I_{CBO}	$V_{CB}=-40V, I_E=0$	-	-	-1	μA
Emitter Cut-off Current		I_{EBO}	$V_{EB}=-4V, I_C=0$	-	-	-1	μA
DC Current Gain	$h_{FE}(1)$ (Note)		$V_{CE}=-2V, I_C=-100mA$	100	-	400	
	$h_{FE}(2)$		$V_{CE}=-2V, I_C=-3A$	35	-	-	
Collector-Emitter Saturation Voltage		$V_{CE(sat)}$	$I_C=-2A, I_B=-100mA$	-	-0.35	-0.7	V
Base-Emitter Saturation Voltage		$V_{BE(sat)}$	$I_C=-2A, I_B=-100mA$	-	-0.94	-1.2	V
Transition Frequency		f_T	$V_{CE}=-10V, I_C=-50mA$	-	150	-	MHz
Collector Output Capacitance		C_{ob}	$V_{CB}=-10V, I_E=0, f=1MHz$	-	39	-	pF
Switching Time	Turn-on Time	t_{on}		-	70	-	nS
	Storage Time	t_{stg}		-	450	-	
	Fall Time	t_f		-	35	-	

Note : $h_{FE}(1)$ Classification A:100 ~ 200, B:140 ~ 280, C:200 ~ 400

$I_C - V_{CE}$

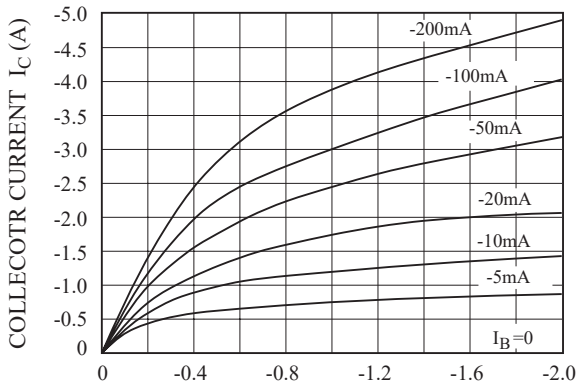

COLLECTOR-EMITTER VOLTAGE V_{CE} (V)

$I_C - V_{BE}$

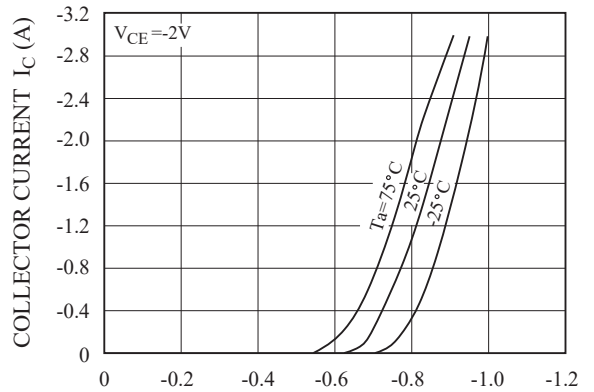

BASE-EMITTER VOLTAGE V_{BE} (V)

$I_C - V_{CE}$

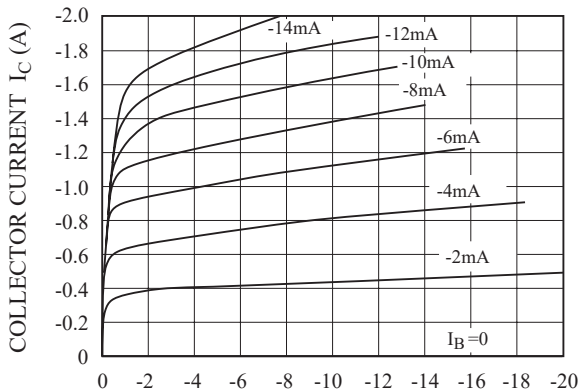

COLLECTOR-EMITTER VOLTAGE V_{CE} (V)

$h_{FE} - I_C$

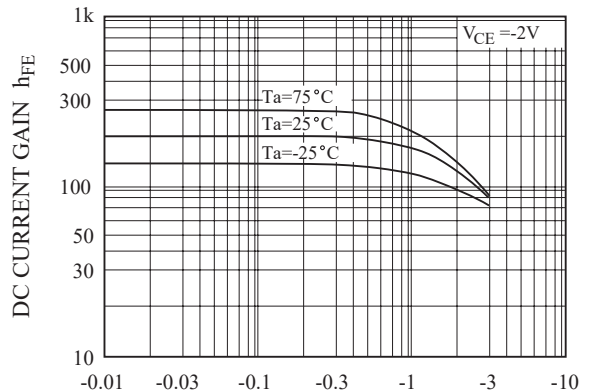

COLLECTOR CURRENT I_C (A)

$V_{CE(sat)} - I_C$

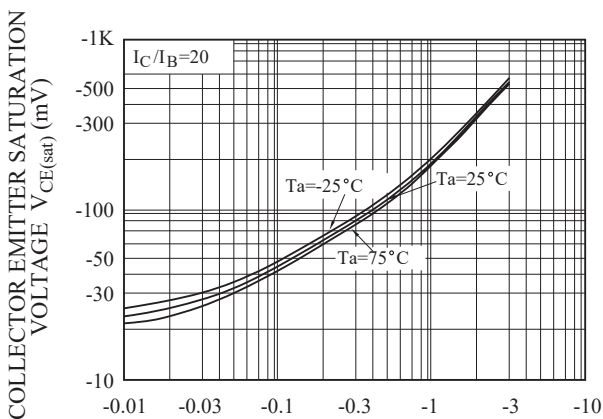

COLLECTOR CURRENT I_C (A)

$V_{BE(sat)} - I_C$

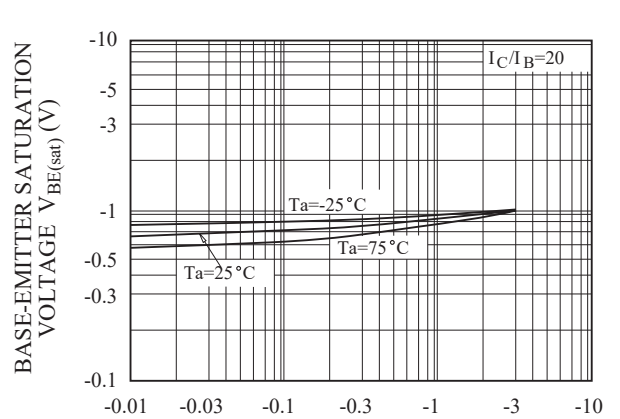

COLLECTOR CURRENT I_C (A)

$f_T - I_C$

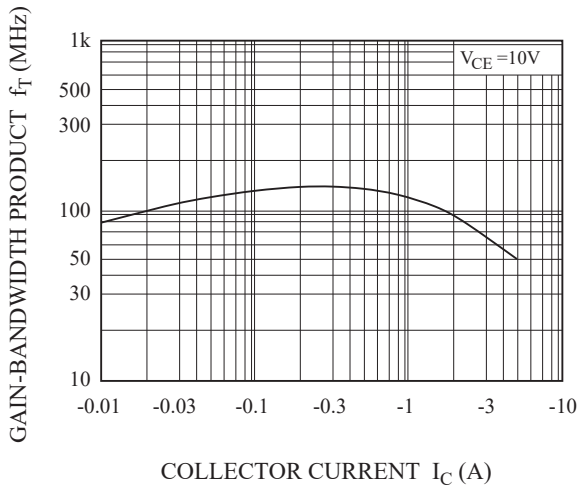

$C_{ob} - V_{CB}$

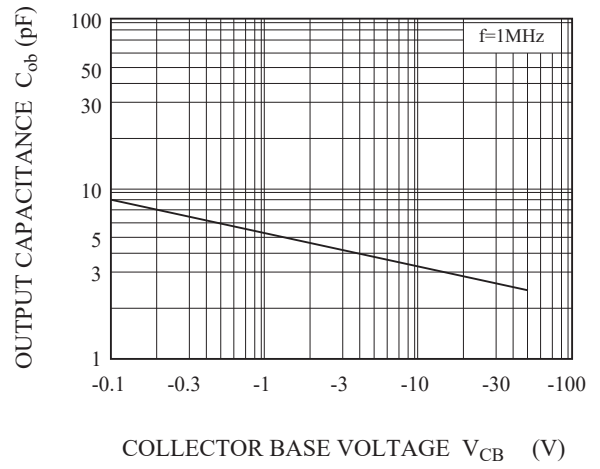

$P_c - T_a$

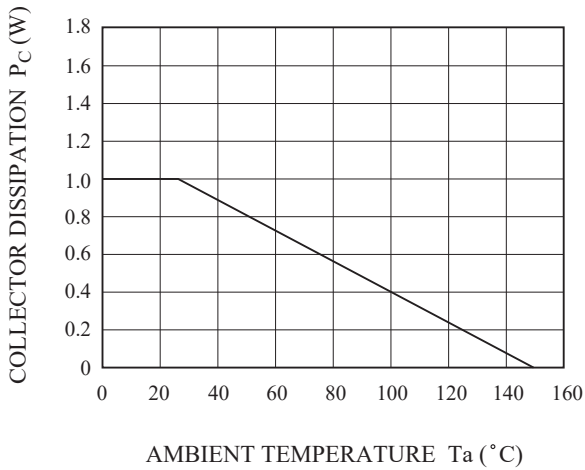

SAFE OPERATING AREA

