

## PROGRAMMABLE PRECISION REFERENCES

The KIA2431P/S/AP/AS are integrated circuits are three-terminal programmable shunt regulator diodes. These monolithic IC voltage reference operate as a low temperature coefficient zener which is programmable from  $V_{ref}$  to 16 volts with two external resistors.

These devices exhibit a wide operating current range of 80  $\mu$ A to 50mA with a typical dynamic impedance of 0.22  $\Omega$ .

The characteristics of these references make them excellent replacements for zener diodes in many applications such as digital voltmeters, power supplies, and op amp circuitry.

## FEATURES

- Programmable Output Voltage to 16 Volts.
- Low Dynamic Output Impedance : 0.22  $\Omega$  (Typ.).
- Sink Current Capability of 80  $\mu$ A to 50mA.
- Equivalent Full-Range Temperature Coefficient of 30ppm/  $^{\circ}$ C (Typ.).
- Temperature Compensated for Operation Over Full Rated Operating Temperature Range.
- Low Output Noise Voltage.
- Suffix U : Qualified to AEC-Q100.  
ex) KIA2431AS-RTK/PU

## LINE UP

ITEM		Package	Vref Tolerance (%)
KIA2431	P	TO-92	$\pm 1.5$
	S	TSM	
	AP	TO-92	$\pm 1.0$
	AS	TSM	

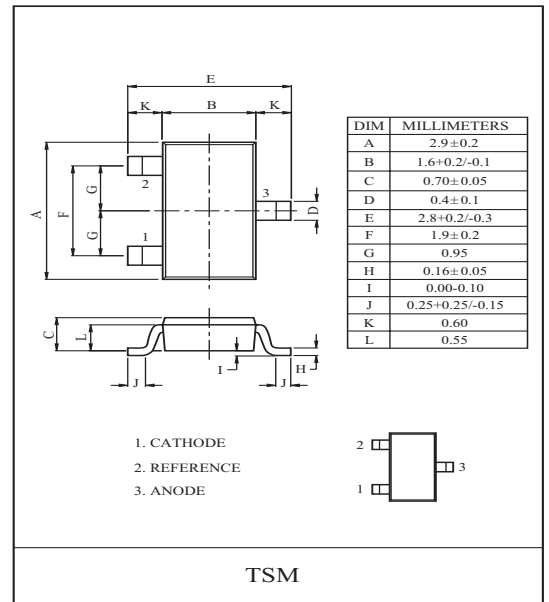
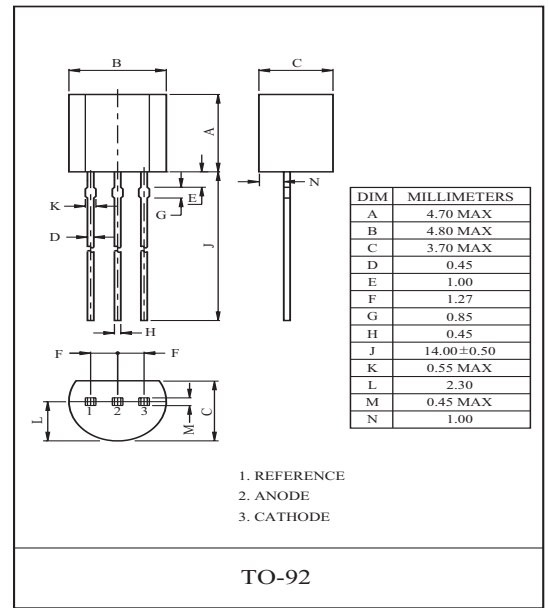

## Marking

Type No.	Marking
KIA2431S	24A
KIA2431AS	24B

# KIA2431P/S/AP/AS

## MAXIMUM RATINGS (Ta=25 °C)

(Full operating ambient temperature range applies unless otherwise noted.)

CHARACTERISTIC		SYMBOL	RATING	UNIT
Cathode To Anode Voltage		$V_{KA}$	16	V
Cathode Current Range, Continuous		$I_K$	50	mA
Reference Input Current Range, Continuous		$I_{ref}$	3	mA
Operating Junction Temperature		$T_j$	150	
Operating Temperature		$T_{opr}$	-40 85	
Storage Temperature		$T_{stg}$	-65 150	
Total Power Dissipation	KIA2431P/AP	$P_D$	700	mW
	KIA2431S/AS (Note1)		900	

Note1) Package Mounted on 99.5% Alumina (10mm × 8mm × 0.6mm)

## BLOCK DIAGRAM

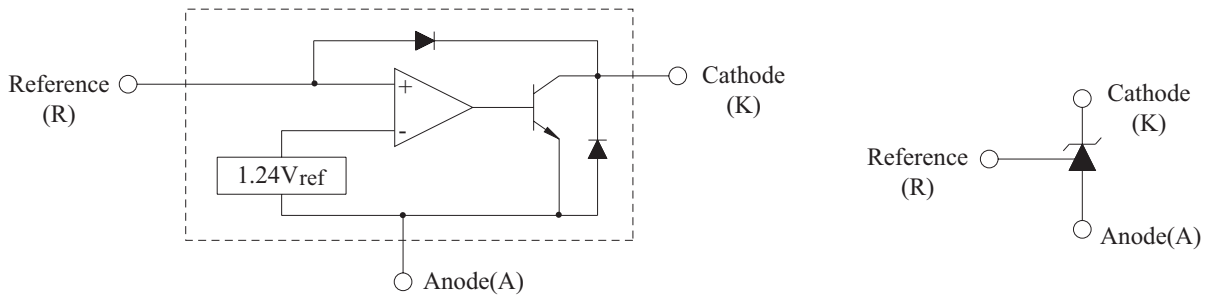

## ELECTRICAL CHARACTERISTICS (Ta=25 °C)

CHARACTERISTICS		SYMBOL	TEST CIRCUIT	TEST CONDITION	MIN.	TYP.	MAX.	UNIT
Reference Input Voltage	KIA2431P/S	$V_{ref}$	Figure 1	$V_{KA}=V_{ref}, I_K=10mA$	1.222	1.240	1.258	V
	KIA2431AP/AS				1.228	1.240	1.252	V
Reference Input Voltage Deviation Over Temperature Range		$V_{ref}$	Figure 1 (Note 1)	$V_{KA}=V_{ref}, I_K=10mA$	-	7.0	20	mV
Ratio of Change in Reference Input Voltage to Change in Cathode to Anode Voltage		$V_{ref}/V_{KA}$	Figure 2	$I_K=10mA, V_{KA}=16V, V_{ref}$	-	-0.6	-1.5	mV/V
Reference Input Current	Ta=25	$I_{ref}$	Figure 2	$I_K=10mA, R1=10k, R2=$	-	0.15	0.5	$\mu A$
Reference Input Current Deviation Over Temperature Range		$I_{ref}$	Figure 2	$I_K=10mA, R1=10k, R2=$	-	0.05	0.3	$\mu A$
Minimum Cathode Current For Regulation		$I_{min}$	Figure 1	$V_{KA}=V_{ref}$	-	55	80	$\mu A$
Off-State Cathode Current		$I_{off}$	Figure 3	$V_{KA}=16V, V_{ref}=0V$	-	2.6	1000	nA
Dynamic Impedance		$Z_{ka}$	Figure 1 (Note 2)	$V_{KA}=V_{ref}, I_K=0.08mA \sim 50mA, f=1.0kHz$	-	0.22	0.4	

# KIA2431P/S/AP/AS

FIGURE 1 - TEST CIRCUIT FOR  $V_{KA} = V_{ref}$

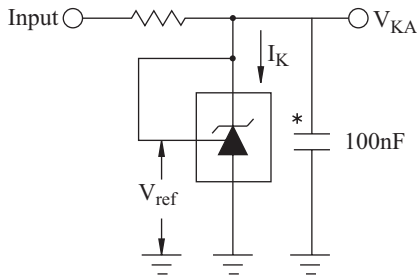
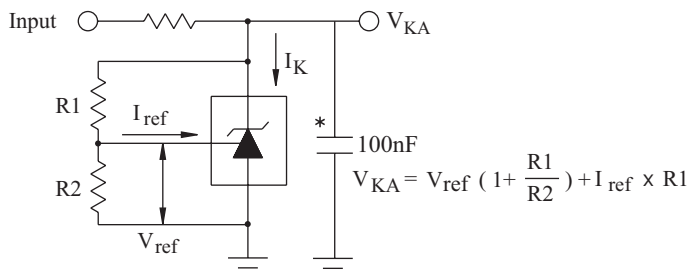

FIGURE 2 - TEST CIRCUIT FOR  $V_{KA} > V_{ref}$



\*  $C_{KA}$  greater than 100nF is needed for stability.

Note 1:

The deviation parameter  $V_{ref}$  is defined as the differences between the maximum and minimum values obtained over the full operating ambient temperature range that applies.

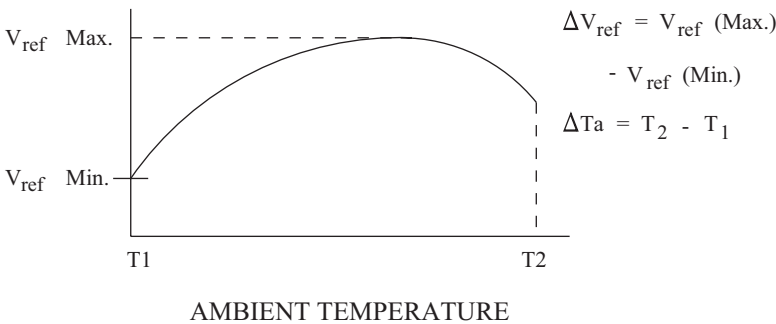

The average temperature coefficient of the Reference input voltage,  $V_{ref}$ , is defined as:

$$V_{ref} \left( \frac{\text{ppm}}{\text{Ta}} \right) = \frac{\left( \frac{V_{ref}}{V_{ref \text{ at } 25}} \right) \times 10^6}{\text{Ta}}$$

$$= \frac{V_{ref} \times 10^6}{\text{Ta}(V_{ref \text{ at } 25})}$$

$V_{ref}$  can be positive or negative depending on whether  $V_{ref \text{ Min.}}$  or  $V_{ref \text{ Max.}}$  occurs at the lower ambient temperature.

FIGURE 3 - TEST CIRCUIT FOR  $I_{off}$

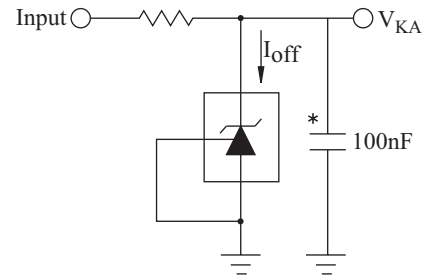

Example :  $V_{ref} = 5.0\text{mV}$  and slope is positive,  
 $V_{ref \text{ at } 25} = 1.245\text{V}$ ,  $T_a = 110$

$$V_{ref} = \frac{0.005 \times 10^6}{110 \times 1.245} = 36.5 \text{ ppm/}$$

Note 2: The dynamic impedance  $Z_{ka}$  is defined as:

$$|Z_{ka}| = \frac{V_{KA}}{I_k}$$

When the device is programmed with two external resistors, R1 and R2, (refer to Figure 2) the total dynamic impedance of the circuit is defined as:

$$|Z_{ka}'| = |Z_{ka}| \left( 1 + \frac{R1}{R2} \right)$$

# KIA2431P/S/AP/AS

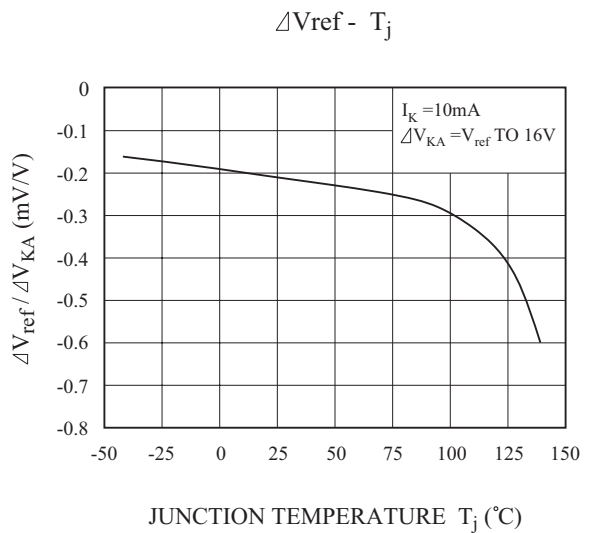
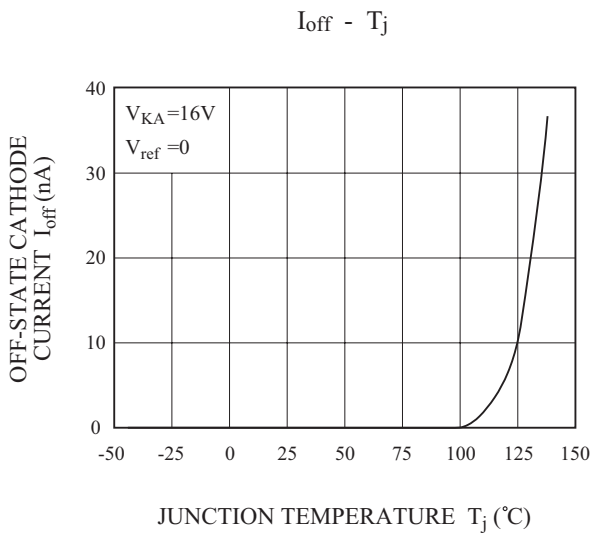
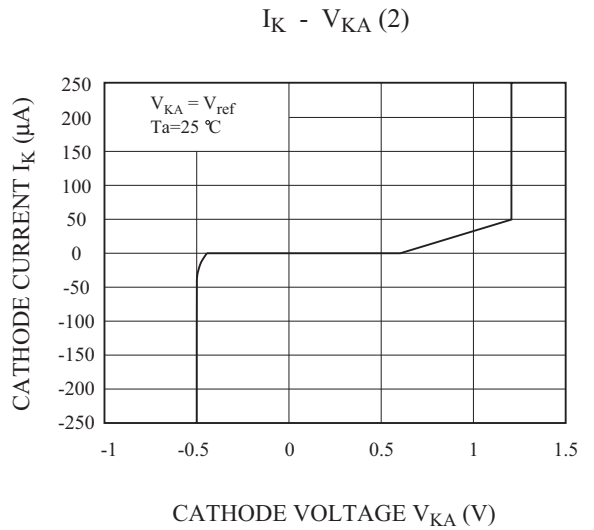
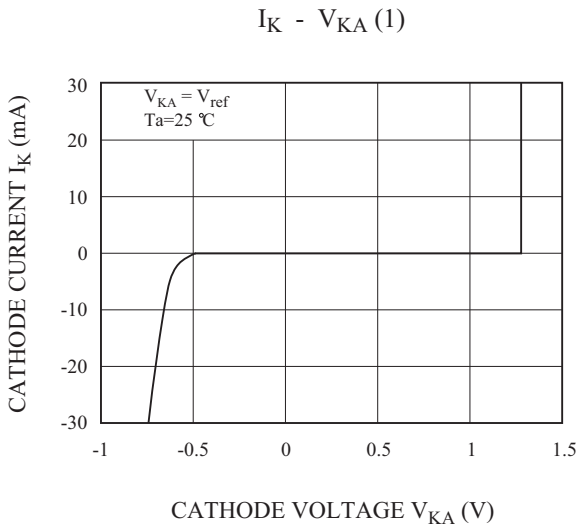
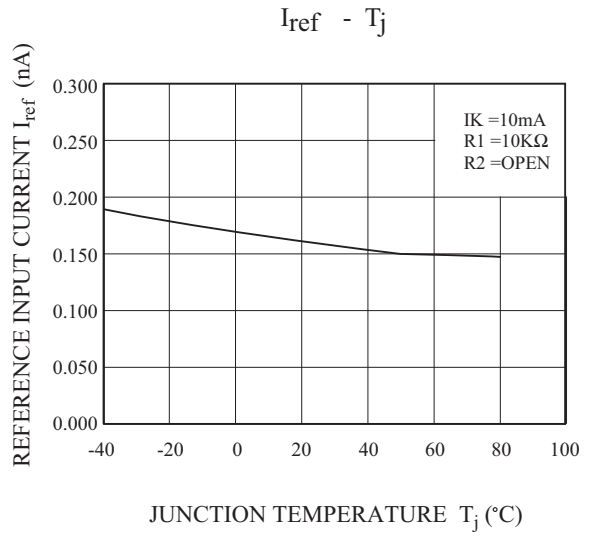
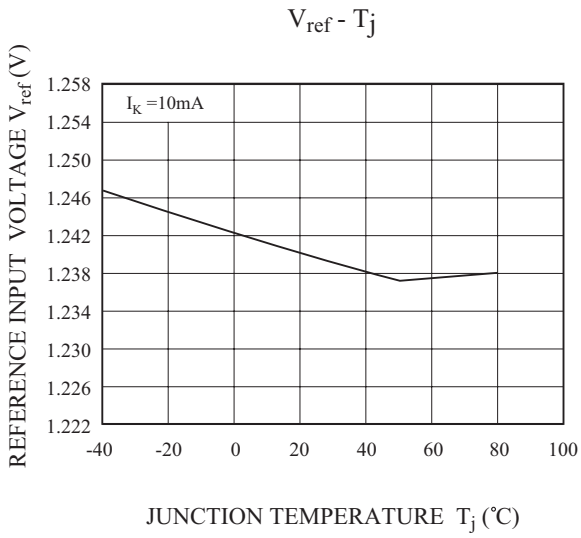

# KIA2431P/S/AP/AS

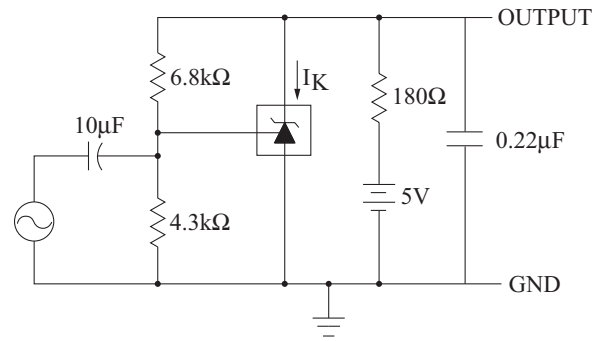
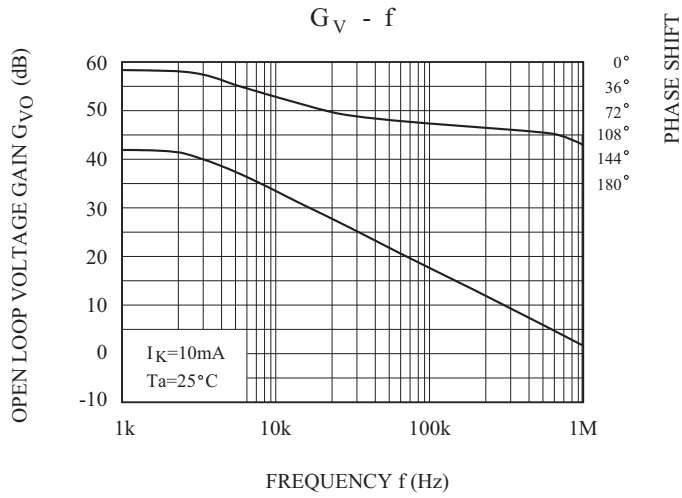

TEST CIRCUIT FOR VOLTAGE GAIN AND PHASE MARGIN

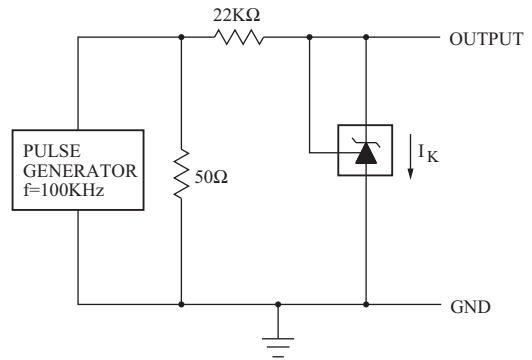
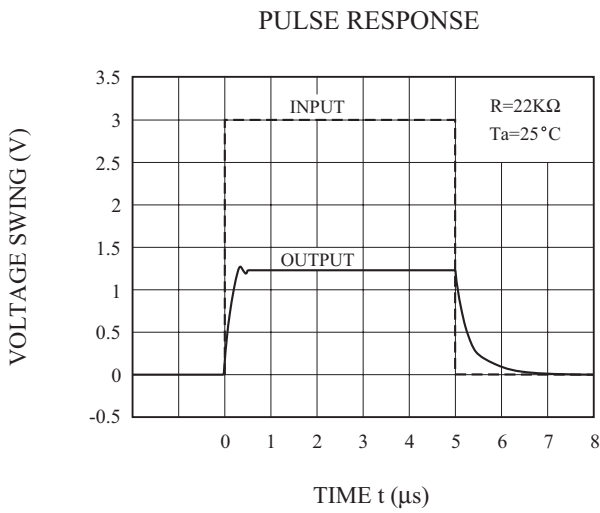

TEST CIRCUIT FOR PULSE RESPONSE2

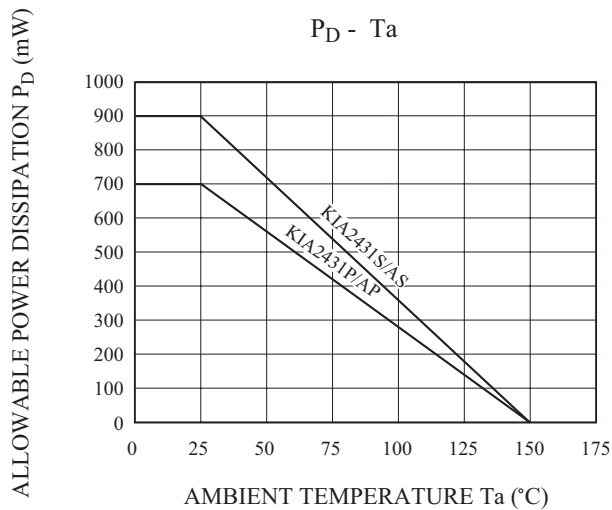

## PRECAUTION FOR USE

### SOLDERING

#### Flat Package (TSM Package)

Elements mounting styles of electronic devices are gaining in further diversification over recent years, and needs for components are all the more expanding in varieties. Especially, surface mounting is steadily penetrating into industrial segments as a world-wide popular technical trend.

Although exposure to high temperature is inevitable during soldering we recommend limiting the soldering temperature to low levels as shown in figure for the sake of retaining inherent excellent reliability.

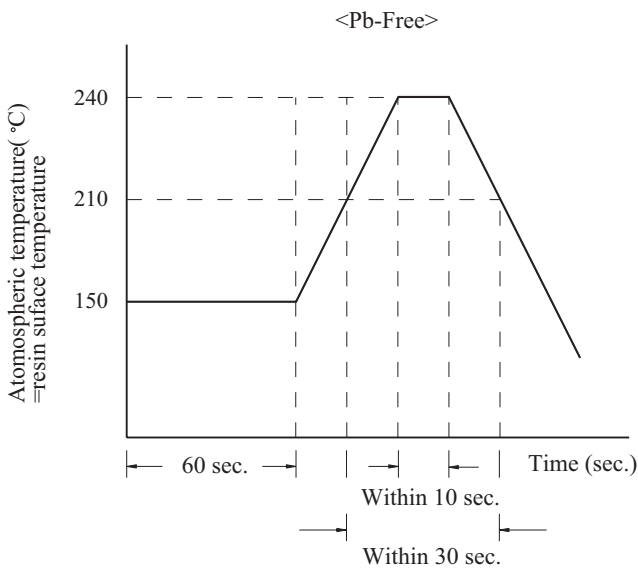

Fig. 6

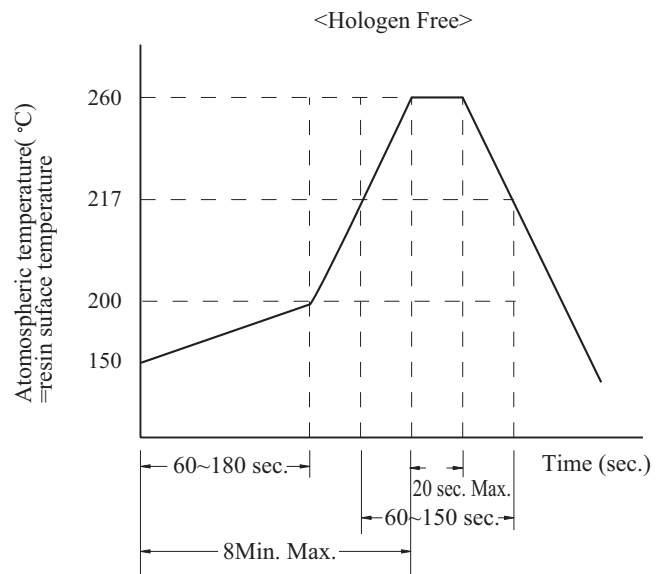

Fig. 7

(a) When employing solder reflow method

Atmospheric temperature around resin surfaces must be less than 240 °C, not exceeding the time length of 10 sec.

Recommend temperature profile

Precautions on heating method

When resin is kept exposed to high temperature for a long time, device reliability may be marred.

Therefore, it is essential to complete soldering in the shortest time possible to prevent temperature of resin from rising.

(b) When employing halogen lamps or infrared-ray heaters

When halogen lamps or infrared-ray heaters are used, avoid direct irradiation onto resin surfaces; such devices cause extensive localized temperature rise.

Please keep a reflow solder operating when TSM package's soldering.