

THREE TERMINAL POSITIVE VOLTAGE REGULATORS 5V, 8V, 12V, 15V.

KIA78M× × Series of three-terminal positive voltage regulators employ built-in current limiting, thermal shutdown, and safe-operating area protection which makes them virtually immune to damage from output overloads. With adequate heatsinking, they can deliver in excess of 0.5A output current.

FEATURES

- Output current in excess of 0.5A.
- No external components.
- Internal thermal overload protection.
- Internal short circuit current limiting.
- Output transistor safe-area compensation.
- Suffix U : Qualified to AEC-Q100.
ex) KIA78M**F-RTF/PU

LINE-UP

ITEM	OUTPUT VOLTAGE (Typ.)	PACKAGE
KIA78M05F/PI	5	F : DPAK, DPAK(3) PI : TO-220IS
KIA78M08F/PI	8	
KIA78M12F/PI	12	
KIA78M15F/PI	15	

MAXIMUM RATING (Ta=25 °C)

CHARACTERISTIC	SYMBOL	RATING	UNIT
Input Voltage	V _{IN}	35	V
Power Dissipation-1 (No Heatsink)	F	1.3	W
	PI	2	
Power Dissipation-2 (Infinite Heatsink)	F	12	W
	PI	20.8	
Operating Junction Temperature	T _j	-40 ~ 150	°C
Storage Temperature	T _{stg}	-55 ~ 150	°C
Soldering Temperature (10 seconds)	T _{sol}	260	°C

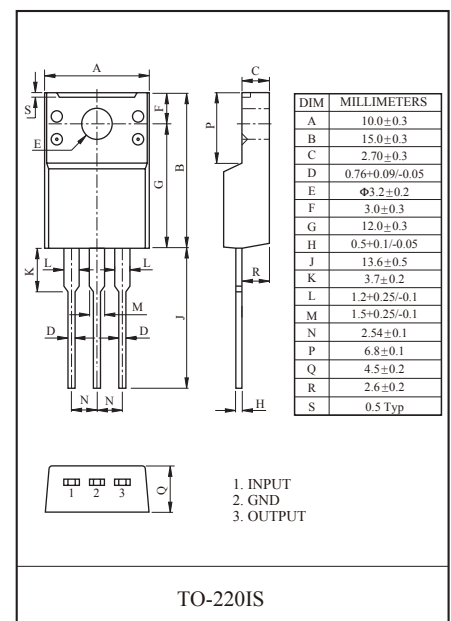
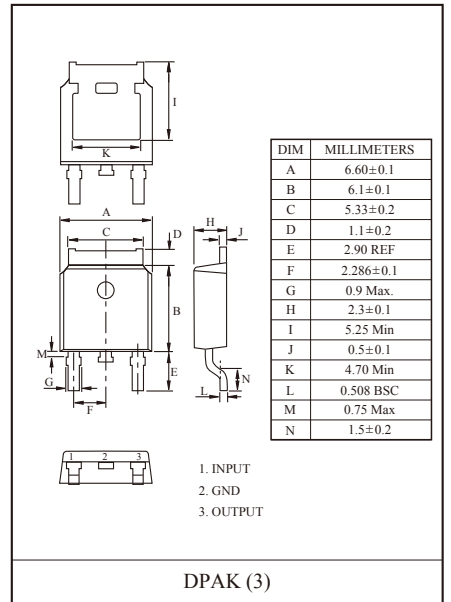
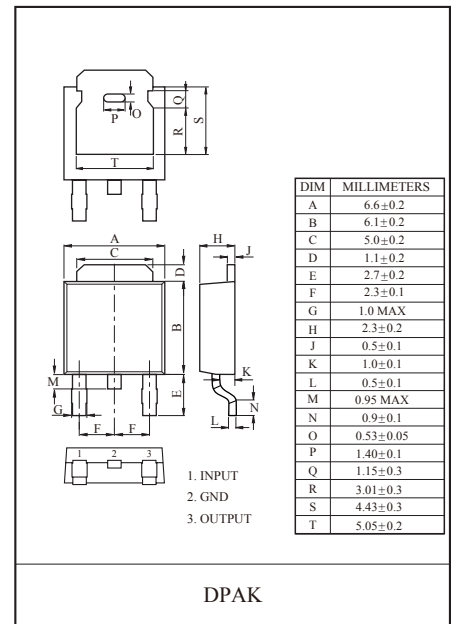

KIA78M05F/PI KIA78M15F/PI

EQUIVALENT CIRCUIT

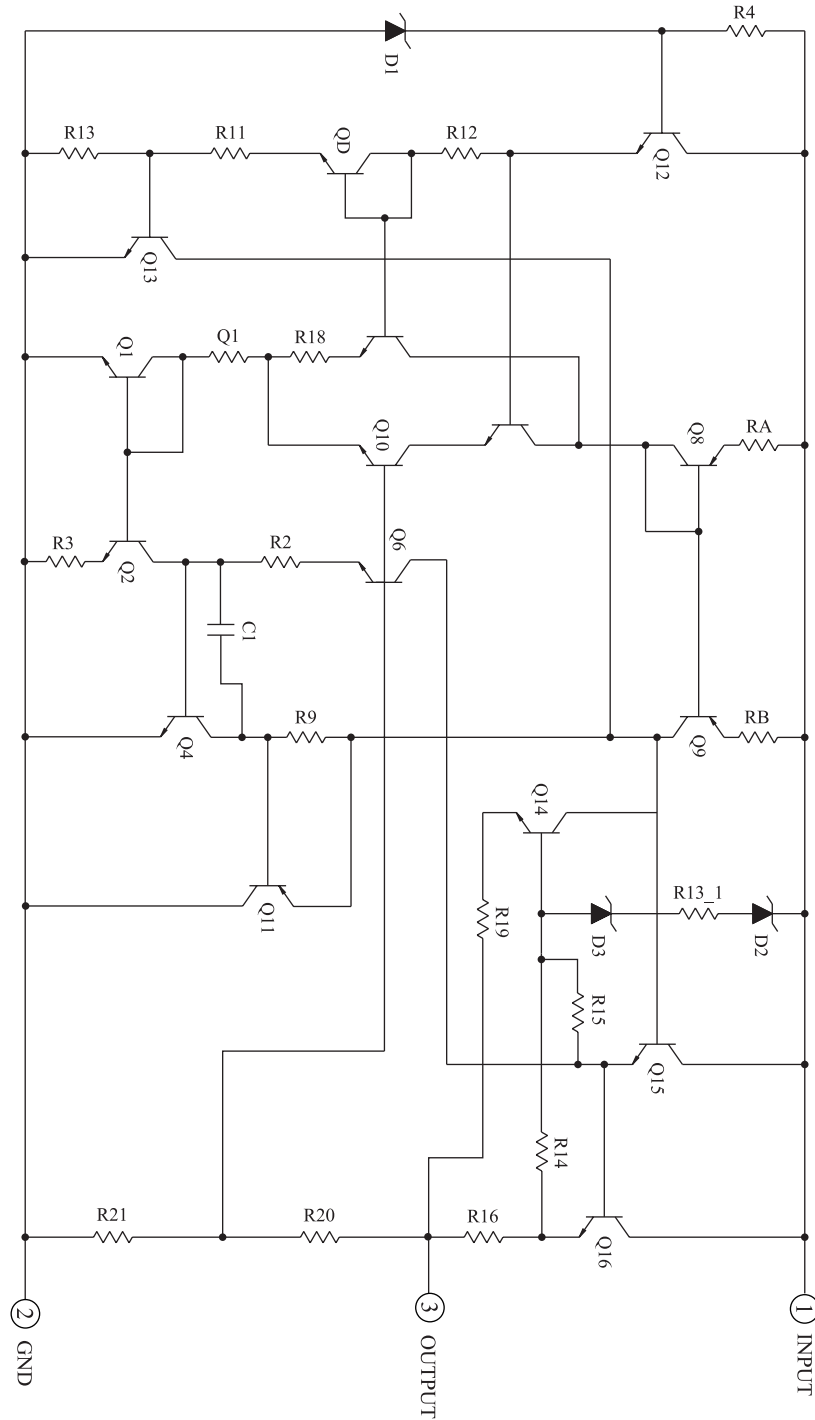

KIA78M05F/PI KIA78M15F/PI

ELECTRICAL CHARACTERISTICS

KIA78M05F/PI

(unless otherwise specified : $V_{IN}=10V$, $I_{OUT}=350mA$, $C_{IN}=0.33 \mu F$, $C_{OUT}=0.1 \mu F$)

CHARACTERISTIC	SYMBOL	TEST CONDITION	MIN.	TYP.	MAX.	UNIT
Output Voltage	V_{OUT}	$T_j=25$	4.8	5.0	5.2	V
		5mA I_{OUT} 350mA P_D 7.5W, 7.5V V_{IN} 20V	4.75	5.0	5.25	
Line Regulation	Reg Line	8V V_{IN} 25V, $I_{OUT}=200mA$	-	-	50	mV
		7.2V V_{IN} 25V, $I_{OUT}=200mA$	-	-	100	
Load Regulation	Reg Load	5mA I_{OUT} 500mA	-	-	100	mV
Quiescent Current	I_B	$T_j=25$	-	4	6	mA
Quiescent Current Change	I_B	5mA I_{OUT} 350mA	-	-	0.5	mA
		7.5V V_{IN} 25V, $I_{OUT}=200mA$	-	-	1.0	mA
Output Noise Voltage	V_{NO}	f=10Hz 100kHz	-	40	-	μV
Ripple Rejection	R · R	f=120Hz, 8V V_{IN} 18V $I_{OUT}=300mA$	62	78	-	dB
Dropout Voltage	V_D	$I_{OUT}=500mA$	-	2.0	-	V
Short Circuit Current	I_{SC}	$V_{IN}=35V$	-	300	-	mA
Output Voltage Drift	V_{OUT}/ T	$I_{OUT}=5mA$, $T_j=0$ 125	-	-0.5	-	mV/

KIA78M05F/PI KIA78M15F/PI

ELECTRICAL CHARACTERISTICS

KIA78M08F/PI

(unless otherwise specified : $V_{IN}=14V$, $I_{OUT}=350mA$, $C_{IN}=0.33\ \mu F$, $C_{OUT}=0.1\ \mu F$)

CHARACTERISTIC	SYMBOL	TEST CONDITION	MIN.	TYP.	MAX.	UNIT
Output Voltage	V_{OUT}	$T_j=25$	7.7	8	8.3	V
		5mA I_{OUT} 350mA P_D 7.5W, 10.5V V_{IN} 23V	7.6	8	8.4	
Line Regulation	Reg Line	11V V_{IN} 25V, $I_{OUT}=200mA$	-	-	50	mV
		10.5V V_{IN} 25V, $I_{OUT}=200mA$	-	-	100	
Load Regulation	Reg Load	5mA I_{OUT} 500mA	-	-	100	mV
Quiescent Current	I_B	$T_j=25$	-	4	6	mA
Quiescent Current Change	I_B	5mA I_{OUT} 350mA	-	-	0.5	mA
		10.5V V_{IN} 25V, $I_{OUT}=200mA$	-	-	1.0	mA
Output Noise Voltage	V_{NO}	$f=10Hz$ 100kHz	-	50	-	μV
Ripple Rejection	$R \cdot R$	$f=120Hz$, 11V V_{IN} 25V $I_{OUT}=300mA$	56	75	-	dB
Dropout Voltage	V_D	$I_{OUT}=500mA$	-	2.0	-	V
Short Circuit Current	I_{SC}	$V_{IN}=35V$	-	300	-	mA
Output Voltage Drift	V_{OUT}/ T	$I_{OUT}=5mA$, $T_j=0$ 125	-	-0.5	-	mV/

KIA78M05F/PI KIA78M15F/PI

ELECTRICAL CHARACTERISTICS

KIA78M12F/PI

(unless otherwise specified : $V_{IN}=19V$, $I_{OUT}=350mA$, $C_{IN}=0.33\mu F$, $C_{OUT}=0.1\mu F$)

CHARACTERISTIC	SYMBOL	TEST CONDITION	MIN.	TYP.	MAX.	UNIT
Output Voltage	V_{OUT}	$T_j=25$	11.5	12	12.5	V
		5mA I_{OUT} 350mA P_D 7.5W, 14.8V V_{IN} 27V	11.4	12	12.6	
Line Regulation	Reg Line	16V V_{IN} 30V, $I_{OUT}=200mA$	-	-	50	mV
		14.5V V_{IN} 30V, $I_{OUT}=200mA$	-	-	100	
Load Regulation	Reg Load	5mA I_{OUT} 500mA	-	-	240	mV
Quiescent Current	I_B	$T_j=25$	-	4	6	mA
Quiescent Current Change	I_B	5mA I_{OUT} 350mA	-	-	0.5	mA
		14.5V V_{IN} 25V, $I_{OUT}=200mA$	-	-	1.0	mA
Output Noise Voltage	V_{NO}	f=10Hz 100kHz	-	75	-	μV
Ripple Rejection	R · R	f=120Hz, 15V V_{IN} 25V $I_{OUT}=300mA$	55	75	-	dB
Dropout Voltage	V_D	$I_{OUT}=500mA$	-	2.0	-	V
Short Circuit Current	I_{SC}	$V_{IN}=35V$	-	300	-	mA
Output Voltage Drift	V_{OUT}/T	$I_{OUT}=5mA$, $T_j=0$ 125	-	-0.5	-	mV/

KIA78M05F/PI KIA78M15F/PI

ELECTRICAL CHARACTERISTICS

KIA78M15F/PI

(unless otherwise specified : $V_{IN}=23V$, $I_{OUT}=350mA$, $C_{IN}=0.33 \mu F$, $C_{OUT}=0.1 \mu F$)

CHARACTERISTIC	SYMBOL	TEST CONDITION	MIN.	TYP.	MAX.	UNIT
Output Voltage	V_{OUT}	$T_j=25$	14.4	15	15.6	V
		5mA I_{OUT} 350mA P_D 7.5W, 18V V_{IN} 30V	14.25	15	15.75	
Line Regulation	Reg Line	20V V_{IN} 30V, $I_{OUT}=200mA$	-	-	50	mV
		17.5V V_{IN} 30V, $I_{OUT}=200mA$	-	-	100	
Load Regulation	Reg Load	5mA I_{OUT} 500mA	-	-	300	mV
Quiescent Current	I_B	$T_j=25$	-	4	6	mA
Quiescent Current Change	I_B	5mA I_{OUT} 350mA	-	-	0.5	mA
		18V V_{IN} 30V, $I_{OUT}=200mA$	-	-	1.0	mA
Output Noise Voltage	V_{NO}	$f=10Hz$ 100kHz	-	90	-	μV
Ripple Rejection	$R \cdot R$	$f=120Hz$, 18.5V V_{IN} 28.5V $I_{OUT}=300mA$	54	70	-	dB
Dropout Voltage	V_D	$I_{OUT}=500mA$	-	2.0	-	V
Short Circuit Current	I_{SC}	$V_{IN}=35V$	-	300	-	mA
Output Voltage Drift	V_{OUT}/ T	$I_{OUT}=5mA$, $T_j=0$ 125	-	-1	-	mV/

Fig. 1
PEAK OUTPUT CURRENT

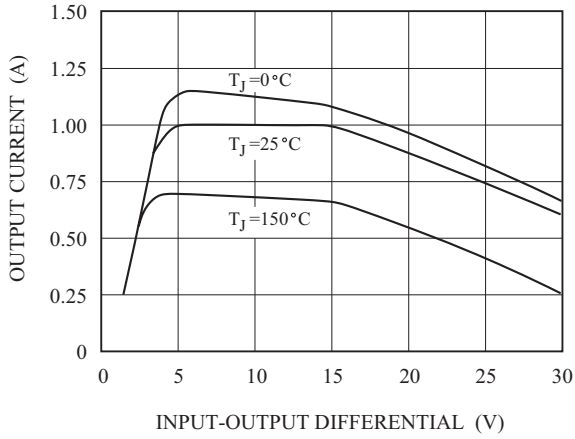

Fig. 2
RIPPLE REJECTION

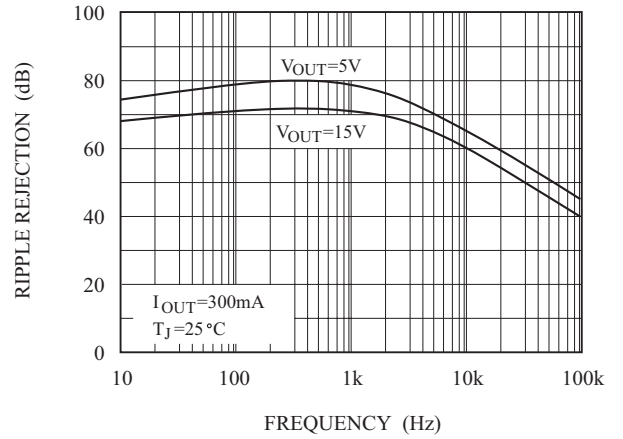

Fig. 3
DROPOUT VOLTAGE

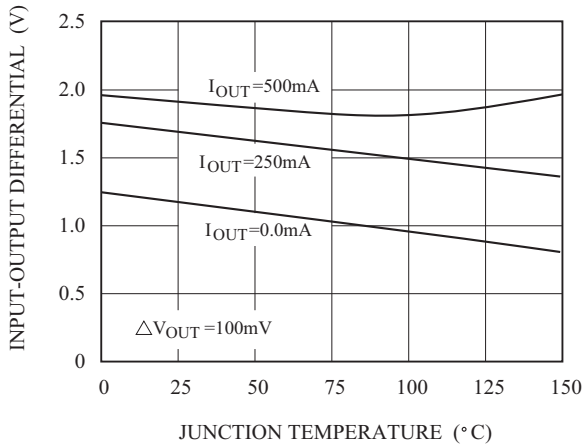

Fig. 4
OUTPUT VOLTAGE
(Normalized to 1V at $T_J = 25^\circ\text{C}$)

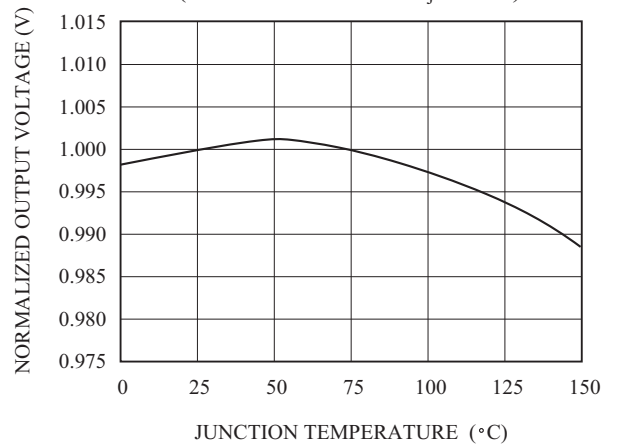

Fig. 5
QUIESCENT CURRENT

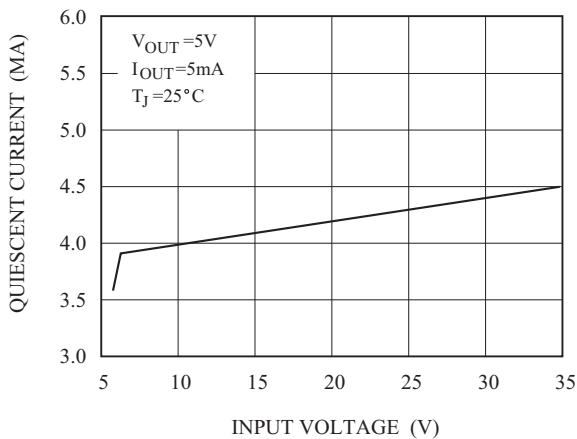
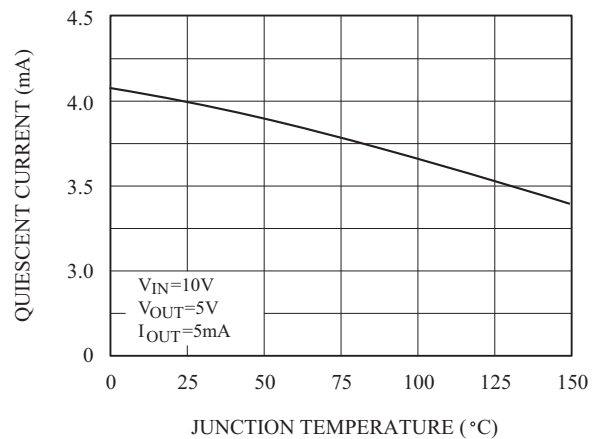
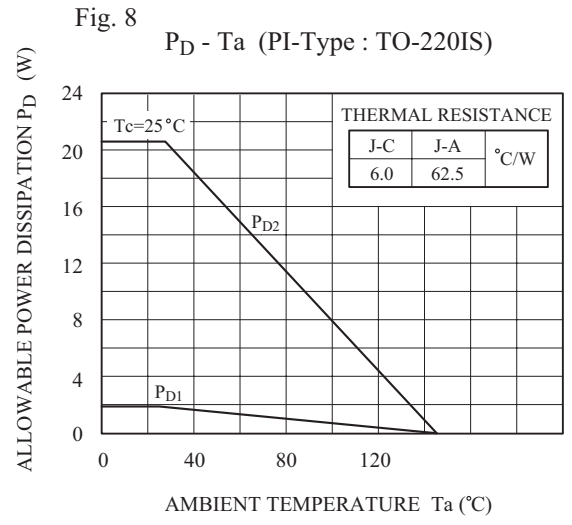
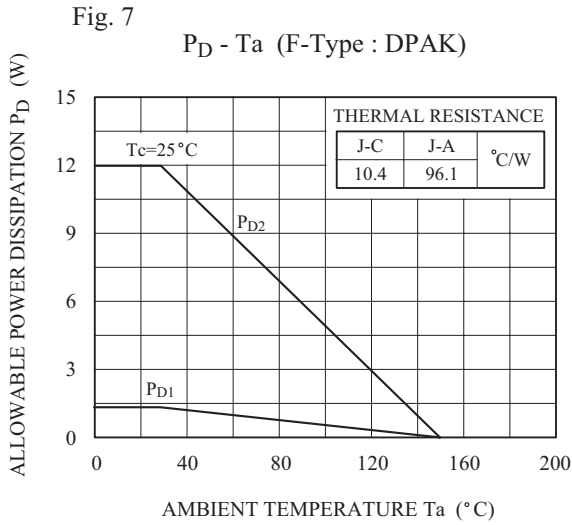

Fig. 6
QUIESCENT CURRENT





Design Considerations

The KIA78MXX fixed voltage regulator series has built-in thermal overload protection which prevents the device from being damaged due to excessive junction temperature. The regulators also contain internal short-circuit protection which limits the maximum output current, and safe-area protection for the pass transistor which reduces the short circuit current as the voltage across the pass transistor is increased. Although the internal power dissipation is automatically limited, the maximum junction temperature of the device must be kept below +150 in order to meet data sheet specifications. An adequate heatsink should be provided to assure this limit is not exceeded under worst-case operating conditions (maximum input voltage and load current) if reliable performance is to be obtained.

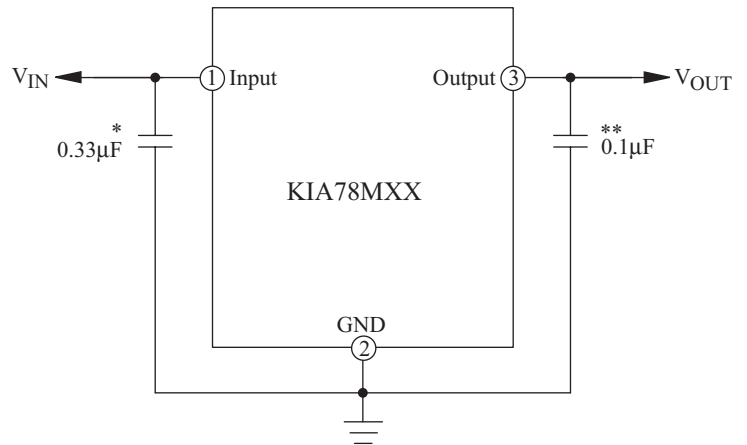

- * Required if regulator input is more than 4 inches from input filter capacitor. (or if no input filter capacitor is used).
- ** Optional for improved transient response.