

PG24LSSMB is designed suitable to protect sensitive automotive circuits against surges defined in ISO 7637-2 and against electrostatic discharges according to IEC 61000-4-2. So it has high reliability and low clamping voltage.

FEATURES

- 1,500 watts peak pulse power capability with a 10/1,000 μ s waveform
- Excellent clamping voltage
- Unidirectional-type
- Package size : 4.5 X 3.6 X 2.3mm³
- Pb-Free, Halogen-Free, Rohs compliant
- Suffix U : Qualified to AEC-Q101
ex) PG24LSSMB-RTF/HU
- Transient protection for automotive circuit and sensitive electronic equipment
 - IEC61000-4-2(ESD) : Air mode \pm 30kV/Contact mode \pm 30kV
 - ISO 7637-2(Pulse 1 IV, 2a/2b IV, 3a/3b IV)

PACKAGE DIMENSION (SMB)

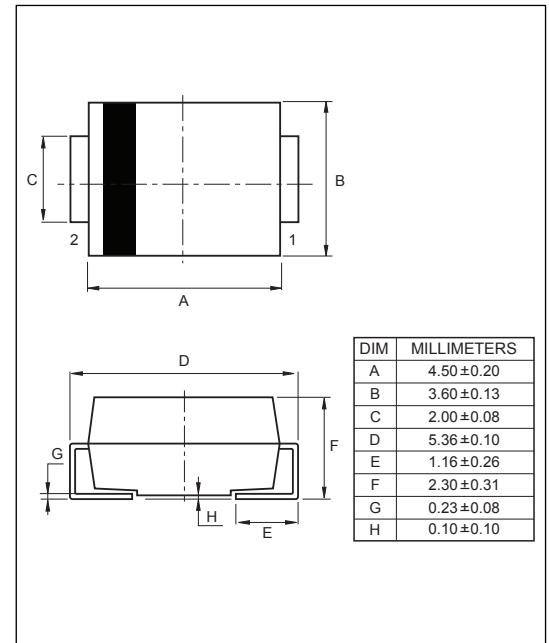

Table 1. Test pulse severity level of nominal 12V, 24V

Test Pulse	Nominal 12V system test pulse severity level			Nominal 24V system test pulse severity level			Min number of pulses or test time	Burst cycle / pulse repetition time	
	IV	III	I / II	IV	III	I / II		Min	Max
1	-150	-112	-75	-600	-450	-300	500 pulse	0.5s	*e
2a	+112	+55	+37	+112	+55	+37	500 pulse	0.2s	5s
2b	+10	+10	+10	+20	+20	+20	10 pulse	0.5s	5s
3a	-220	-165	-112	-300	-220	-150	1h	90ms	100ms
3b	+150	+75	+75	+300	+220	+150	1h	90ms	100ms

*e) The maximum pulse repetition times shall be chosen such that it is the minimum time for the DUT to be correctly initialized before the application of the next pulse and shall \geq 0.5s

MECHANICAL DATA

- Package : SMB
- Molding compound flammability rating : UL94V-0
- Moisture sensitivity : level 1, per J-STD-020
- Terminal : Matter tin plated leads, solderable per J-STD-002
- Polarity indicator : Cathode band
- Weight : \approx 0.1grams

PRODUCT DATASHEET

Single Line TVS Diode– PG24LSSMB

APPLICATIONS

- Motor control
- Inside cabin(lighting)
- Headlamps(lighting)
- ECU(lighting)
- E-call
- Engine cooling system
- Infotainment and navigation
- Camera
- Remote keyless entry
- On-board battery charger
- Battery Management system(BMS)
- Vehicle communication
- Power line

ORDERING INFORMATION

PART NUMBER	QTY per reel	Reel size
PG24LSSMB-RTF	3,000	13 inch

PIN CONFIGURATION

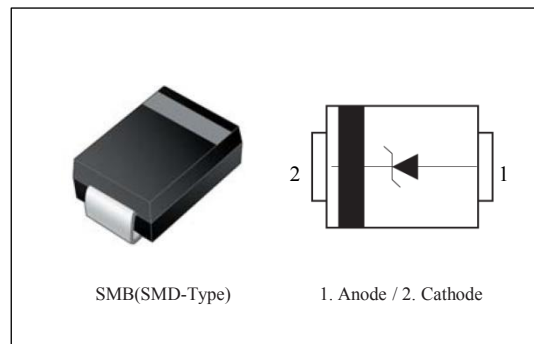

MARKING CODE

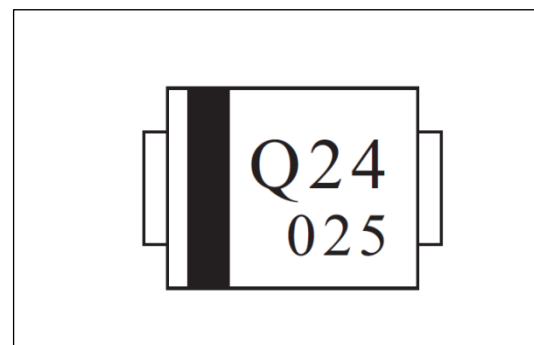

PRODUCT DATASHEET

Single Line TVS Diode– PG24LSSMB

MAXIMUM RATING (Ta=25°C)

CHARACTERISTIC	SYMBOL	RATING	UNIT
Peak Pulse Power with 10/1,000 μs waveform (Note 1, Note 2, Fig 1)	P_{PK}	1,500	W
Peak Pulse Power with 10/1,000 μs waveform (Note 1, Note 2, Fig 1)	I_{PP}	43.5	A
Peak forward surge current with 8.3ms single half sine wave (Note 1, Note 2)	I_{FSM}	270	A
Junction Temperature	T_J	150	°C
Operating junction temperature	T_{opr}	-40 ~ 150	°C
Storage Temperature	T_{STG}	-40 ~ 150	°C

Note 1) Non-repetitive pulse

Note 2) Mounted on a pad dimension 5 X 5mm to each terminals in FR-4 glass epoxy board of 20 X 20mm.

THERMAL CHARACTERISTICS

CHARACTERISTIC	SYMBOL	TEST CONDITION	VALUE	UNIT
Thermal Resistance(Note 2)	$R_{th(j-a)}$	Junction to Ambient	Typ 85	°C/W

Note 2) Mounted on a pad dimension 5 X 5mm to each terminals in FR-4 glass epoxy board of 20 X 20mm.

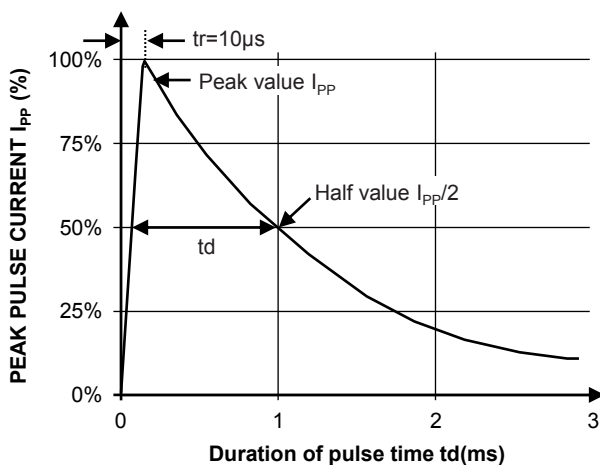

Fig.1 Pulse waveform

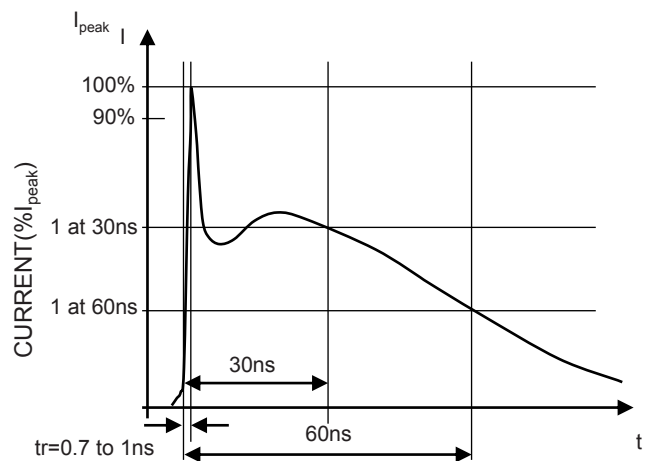
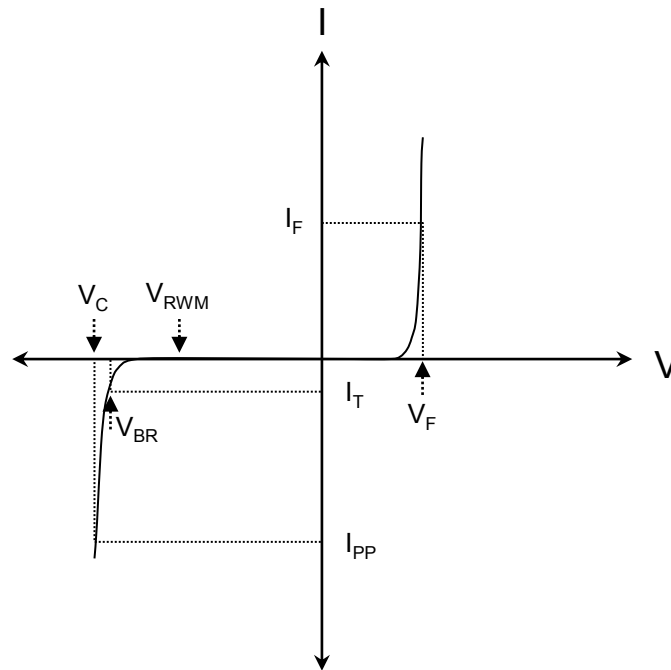

Fig.2 An idealized ESD pulse according to the IEC61000-4-2 Standard

DEFINITIONS OF ELECTRICAL CHARACTERISTIC SYMBOL



V_{RWM}	Maximum voltage rated for DC operating voltage.
I_R	The maximum leakage current is the maximum current measured at the working voltage.
V_{BR}	The breakdown voltage is the minimum reverse voltage that makes the diode conduct appreciably in reverse.
γ_Z	Variation value of voltage due to temperature change.
V_C	Maximum voltage drop during going to I_{PP} .(Limited voltage)
R_{DYN}	Current fluctuation rate / voltage fluctuation rate.
C_T	Capacitance of device.
V_{ESD}	A discharge voltage in which a finite amount of charge rapidly moves between two objects having different potentials.

ELECTRICAL CHARACTERISTICS (Ta=25°C)

CHARACTERISTIC	SYMBOL	TEST CONDITION	MIN.	TYP.	MAX.	UNIT	
Reverse Stand-Off Voltage	V_{RWM}	-	-	-	24	V	
Reverse Leakage Current	I_R	$V_R=24V$	-	-	100	nA	
Breakdown Voltage	V_{BR}	$I_T=1mA$	26.7	-	29.5	V	
Temperature Coefficient(Note 2)	γ_Z	$I_T=1mA(@Ta=25\text{ to }85^\circ C)$	-	20	-	mV/°C	
Clamping Voltage(Note1, Fig 1)	V_{C1}	$I_{PP1}=1A, tp=10/1,000\mu s$	-	-	30.0	V	
	V_{C2}	$I_{PP2}=43.5A, tp=10/1,000\mu s$	-	-	34.5	V	
Dynamic Resistance	R_{DYN}	$(V_{C2}-V_{C1})/(I_{PP2}-I_{PP1})$	-	0.11	-	Ω	
Total Capacitance	C_T	$V_R=0V, f=1MHz$	-	-	2,000	pF	
Electrostatic Discharge	V_{ESD}	IEC61000-4-2	Air	± 30	-	-	kV
			Contact	± 30	-	-	

Note 1) Non-repetitive pulse

Note 2) Mounted on a pad dimension 5 X 5mm to each terminals in FR-4 glass epoxy board of 20 X 20mm.

PRODUCT DATASHEET

Single Line TVS Diode- PG24LSSMB

NON-REPETITIVE PEAK PULSE POWER VS. PULSE TIME

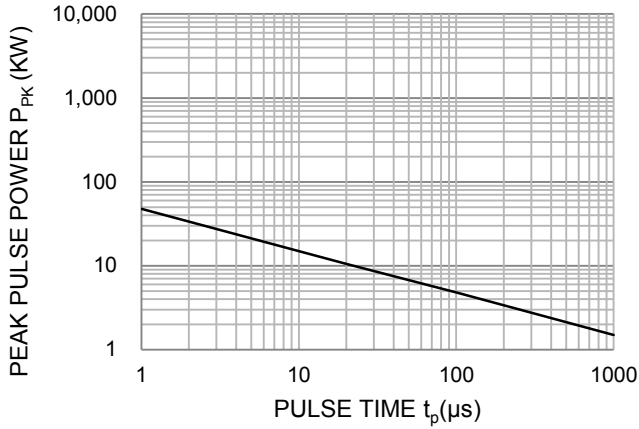

POWER DERATION CURVE

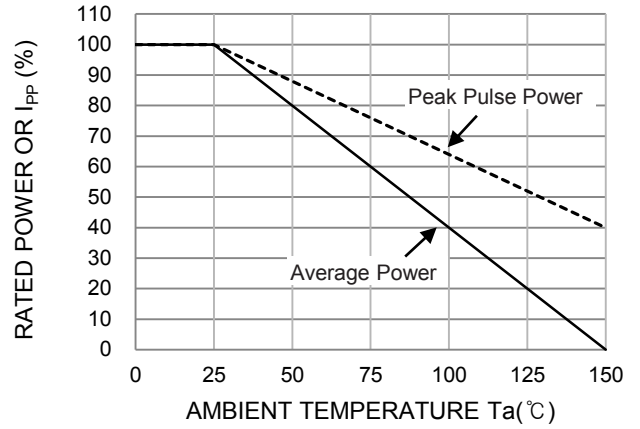

TEST CURRENT VS. BREAKDOWN VOLTAGE

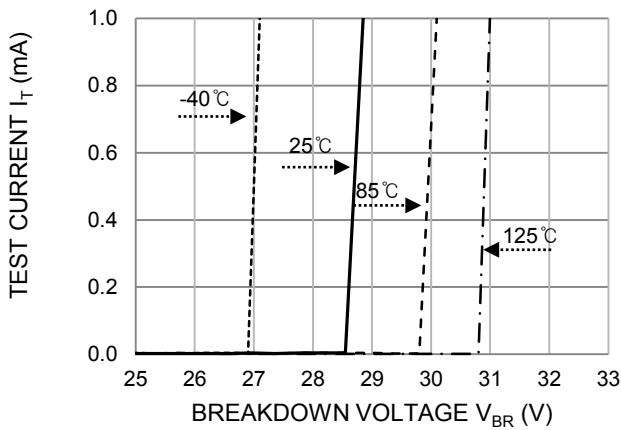

REVERSE LEAKAGE CURRENT VS. REVERSE VOLTAGE

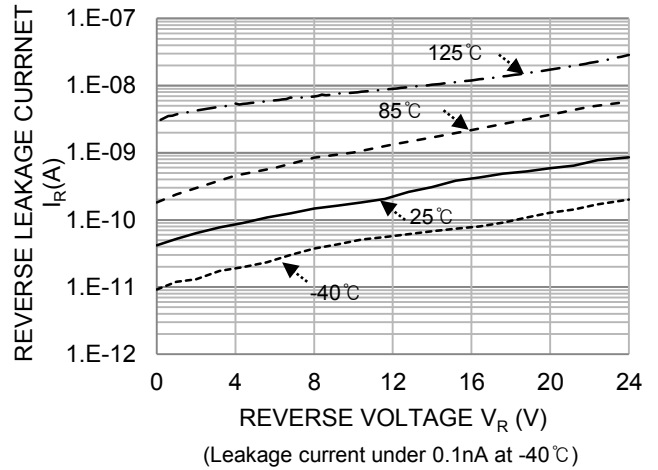

PEAK PULSE CURRENT VS. CLAMPING VOLTAGE

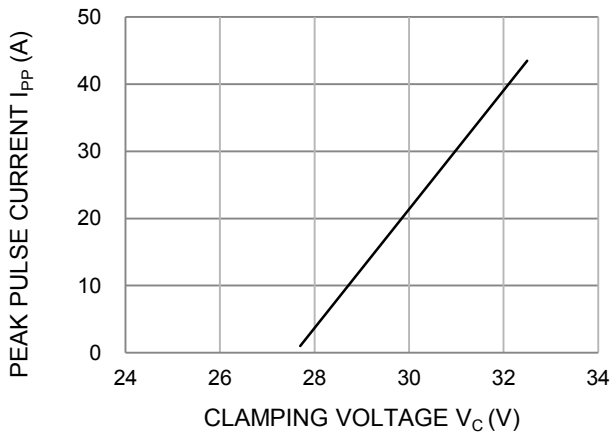

I_{FSM} - CYCLE CHARACTERISTICS

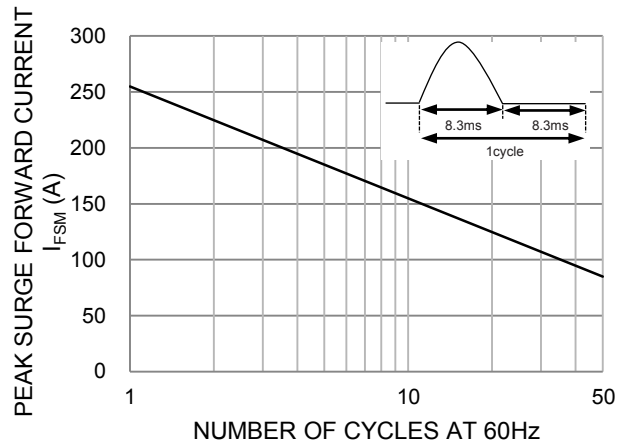

PRODUCT DATASHEET

Single Line TVS Diode- PG24LSSMB

TOTAL CAPACITANCE VS. REVERSE VOLTAGE

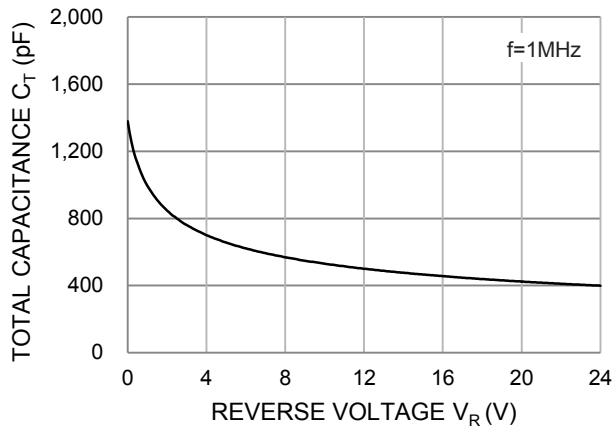

THERMAL RESISTANCE VS. POWER TIME

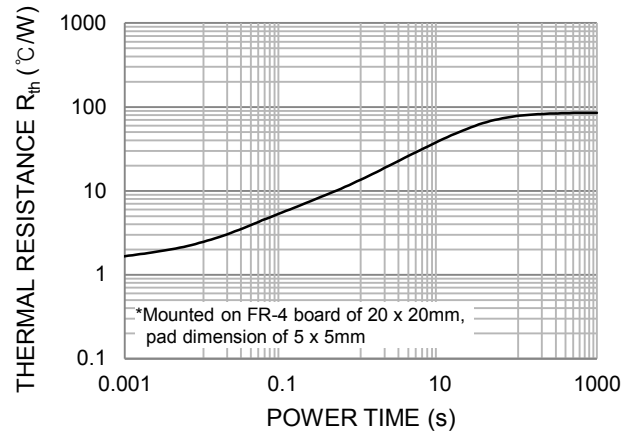

PRODUCT DATASHEET
Single Line TVS Diode- PG24LSSMB

PACKAGE INFORMATION (SMB)

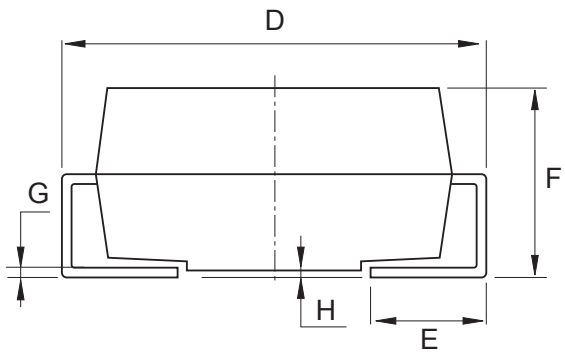
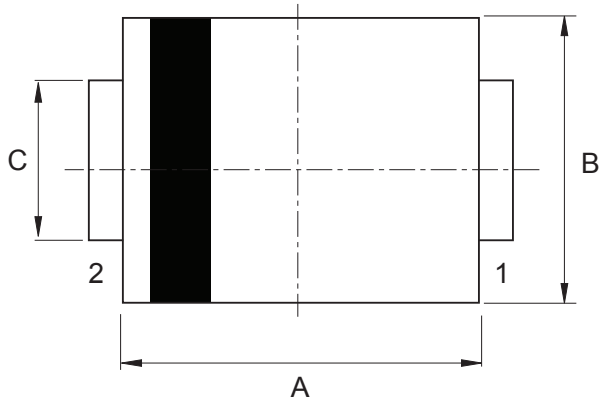

DIM	MILLIMETERS
A	4.50 ±0.20
B	3.60 ±0.13
C	2.00 ±0.08
D	5.36 ±0.10
E	1.16 ±0.26
F	2.30 ±0.31
G	0.23 ±0.08
H	0.10 ±0.10

RECOMMENDED PAD DIMENSION

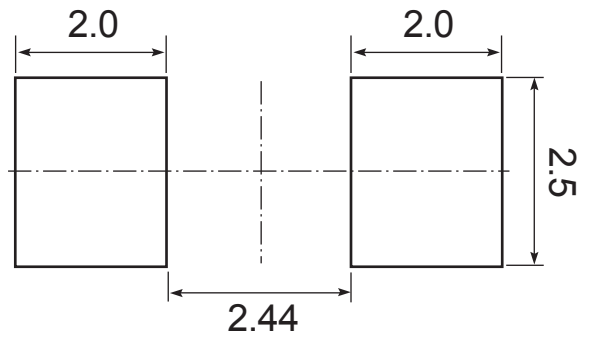

[unit : mm]

PRECAUTION ON USING KEC PRODUCTS

1. The products described in this data are intended to be used in general-purpose electronic equipment (Office equipment, telecommunication equipment, measuring equipment, home appliances)
2. When you intend to use these products with equipment or device which require an extremely high of reliability and special applications (such as automobile, air travel aerospace, transportation equipment, life support, system and safety devices) in which special quality and reliability and the failure or malfunction of products may directly jeopardize or harm the human body or damage to property and any application other than the standard application intended, please be sure to consult with our sales representative in advance.
3. On designing your application, please use product within the ranges guaranteed by KEC for maximum rating, operating supply voltage range, heat radiation characteristics and other characteristics. User shall be responsible for failure or damage when used beyond the guaranteed ranges.
4. The technical information described in this data is limited to showing representative characteristics and applied circuit examples of the products and it does not constitute the warranting of industrial property, the granting of relative rights, or the granting of any license.
5. What are described in the data may be changed without any prior notice to reflect new technical development. Please confirm that you have received the latest product standards or specification before final design, purchase or use.
6. Although KEC is continuously working to improve product reliability and quality, semiconductors can break down and malfunction due to various factors. Therefore, in order to prevent personal injury or fire arising from failure, please take safety measures such as complying with the derating characteristics, implementing redundant and fire prevention designs, and utilizing backups and fail-safe procedures. KEC shall have no responsibility for any damages arising out of the use of our Products beyond the rating specified by KEC.

For additional information,
please contact your local Sales Representative.

SOUTH KOREA (Headquarters)
KEC CORPORATION
PHONE : +82-2-2025-5000
sales@kec.co.kr

JAPAN
KEC JAPAN CO.,LTD.
PHONE : +81-03-5475-2691
kec_jp@kec.co.kr

SINGAPORE
KEC SINGAPORE PTE., LTD.
PHONE : +65-6748-7372(#102)
kec_twn@kec.co.kr

THAILAND
KEC THAILAND BANGKOK OFFICE
PHONE : +66-2-576-1484~5
kec_th@kec.co.kr

CHINA
KEC SHANGHAI CO.,LTD.
PHONE : +86-21-5490-2277
kec_sh@kec.co.kr

KEC SHENZHEN OFFICE
PHONE : +86-755-8882-9198
kec_hk@kec.co.kr

KEC TIANJIN OFFICE
PHONE : +86-22-2330-7562
kec_sh@kec.co.kr

HONG KONG
KEC HK CORP. LTD
PHONE : +852-2249-3734
kec_hk@kec.co.kr

TAIWAN
KEC TAIWAN CO.,LTD.
PHONE : +886-2-2515-8359
kec_twn@kec.co.kr

U.S.A
KEC AMERICA CORP.
PHONE : +1-714-259-0662
kec_a@kec.co.kr

