

Protection in Portable Electronics Applications.

FEATURES

- Transient protection for data lines to
 - IEC61000-4-2(ESD) : Air mode $\pm 30\text{kV}$ / Contact mode $\pm 30\text{kV}$
 - IEC61000-4-4(EFT) : $80\text{A}(t_p=5/50\text{ns})$
 - IEC61000-4-5(Surge) : $6\text{A}(t_p=8/20\ \mu\text{s})$
- Low capacitance $C_T = 9\text{pF}(\text{Max})$
- Bi-directional, symmetrical working voltage up to : $V_{RWM} = \pm 5\text{V}$
- Package Size $1.2 \times 0.8 \times 0.6\text{mm}$
- Low reverse current : $<10\text{nA}$ typical ($V_{RWM}=5\text{V}$)
- Suffix U : Qualified to AEC-Q101.

ex) PS05CBESC-RTK/HU



ESC (Lead-type)

PRODUCT DESCRIPTION

- Molding compound flammability rating : UL 94V-0
- Pb-Free, Halogen-Free, RoHs Compliant

Package dimensions (ESC)	Pin configurations (Bi-directional)																
<table border="1"> <thead> <tr> <th>DIM</th> <th>MILLIMETERS</th> </tr> </thead> <tbody> <tr> <td>A</td> <td>1.60±0.10</td> </tr> <tr> <td>B</td> <td>1.20±0.10</td> </tr> <tr> <td>C</td> <td>0.80±0.10</td> </tr> <tr> <td>D</td> <td>0.30±0.05</td> </tr> <tr> <td>E</td> <td>0.60±0.10</td> </tr> <tr> <td>F</td> <td>0.13±0.05</td> </tr> <tr> <td>G</td> <td>0.20±0.10</td> </tr> </tbody> </table>	DIM	MILLIMETERS	A	1.60±0.10	B	1.20±0.10	C	0.80±0.10	D	0.30±0.05	E	0.60±0.10	F	0.13±0.05	G	0.20±0.10	<p>1. CATHODE 2. CATHODE</p>
DIM	MILLIMETERS																
A	1.60±0.10																
B	1.20±0.10																
C	0.80±0.10																
D	0.30±0.05																
E	0.60±0.10																
F	0.13±0.05																
G	0.20±0.10																

ORDERING INFORMATION

Part Number	Qty per Reel	Reel Size	Marking code
PS05CBESC-RTK	3,000	7 inch	C5
PS05CBESC-RTL	6,000		

PS05CBESC

MAXIMUM RATING (Ta=25°C)

CHARACTERISTIC	SYMBOL	RATING	UNIT
Peak Pulse Power (tp=8/20μs)	P _{PK}	75	W
Peak Pulse Current (tp=8/20μs)	I _{PP}	6	A
Junction Temperature	T _J	150	°C
Storage Temperature	T _{stg}	-55 ~ 150	°C

DEFINITIONS OF ELECTRICAL CHARACTERISTIC SYMBOL

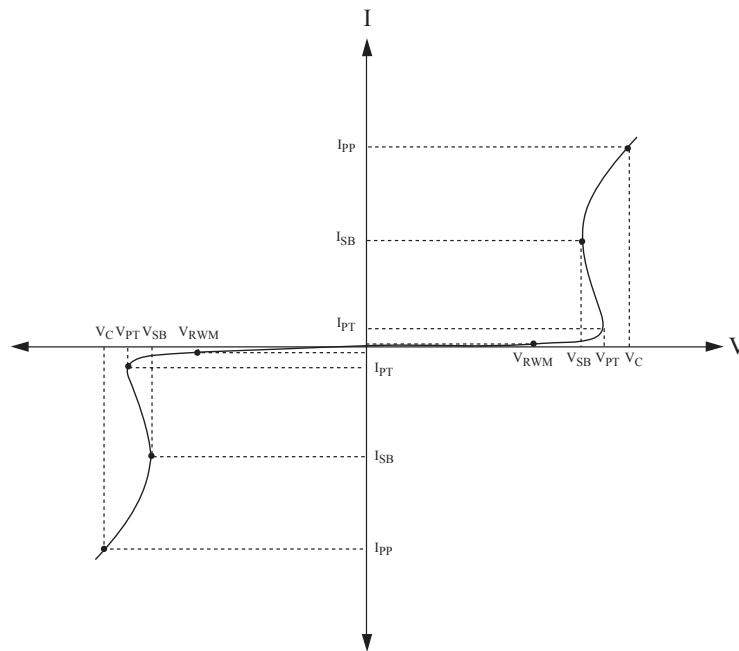

ELECTRICAL CHARACTERISTICS (Ta=25°C)

CHARACTERISTIC	SYMBOL	TEST CONDITION	MIN.	TYP.	MAX.	UNIT	
Reverse Stand-Off Voltage	V _{RWM}	-	-	-	5	V	
Reverse Leakage Current	I _R	V _{RWM} =5V	-	10	50	nA	
Snap-back Voltage	V _{SB}	I _{SB} =100 μA, I _{SB} =50mA	5.5	-	-	V	
Punch-through Voltage	V _{PT}	I _{PT} =2 μA	6	8.2	9.5	V	
Total Capacitance	C _T	V _R =0V, f=1MHz	-	6	9	pF	
Clamping Voltage	V _C	I _{PP} =1A, tp=8/20 μs	-	-	8	V	
		I _{PP} =6A, tp=8/20 μs	-	-	12.5		
		I _{TLP} =4A, tp=100ns	-	7	12		
		I _{TLP} =24A, tp=100ns	-	12	17		
Electrostatic Discharge	V _{ESD}	IEC61000-4-2	Air	±30	-	-	kV
			Contact	±30	-	-	

PS05CBESC

NON-REPETITIVE PEAK PULSE POWER VS. PULSE TIME

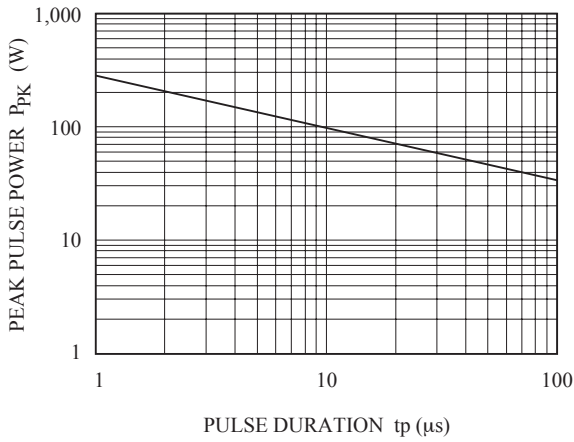

POWER DERATION CURVE

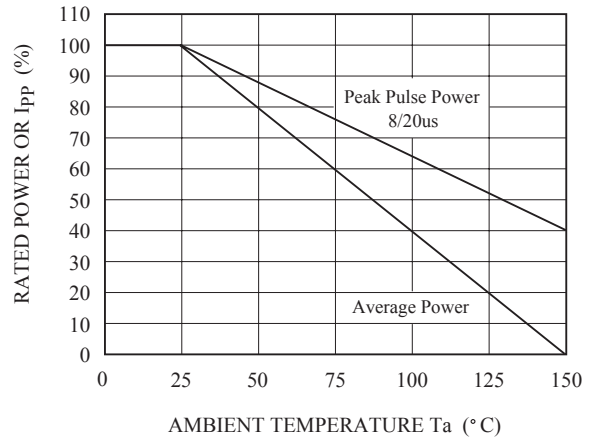

$I_R - V_R$

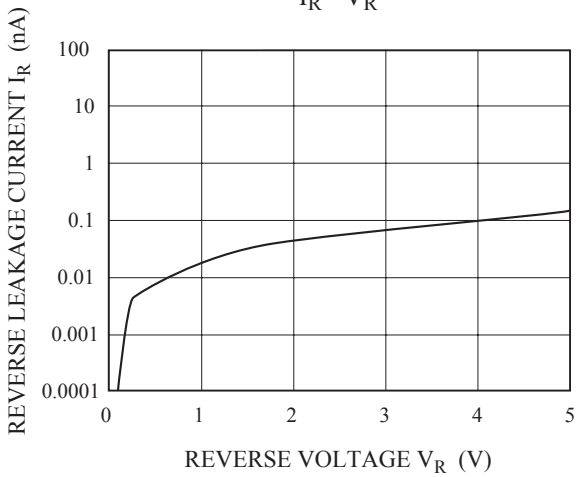

$C_T - V_R$

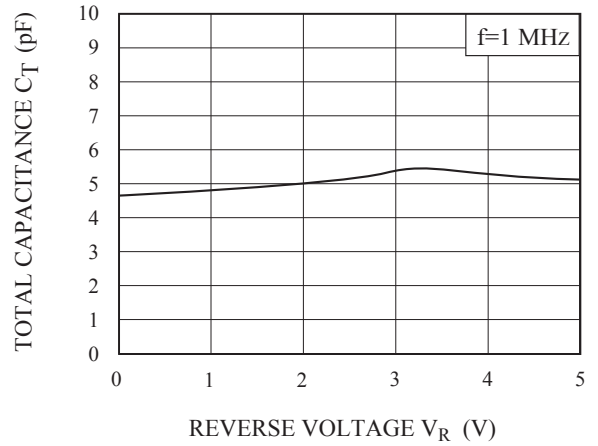

$I_{PP} - V_C$

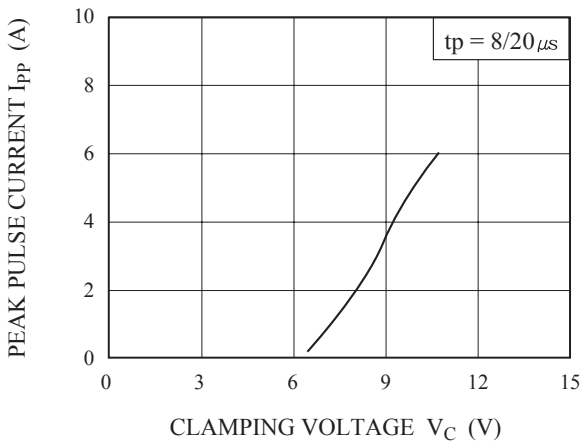

$I_{TLP} - V_C$

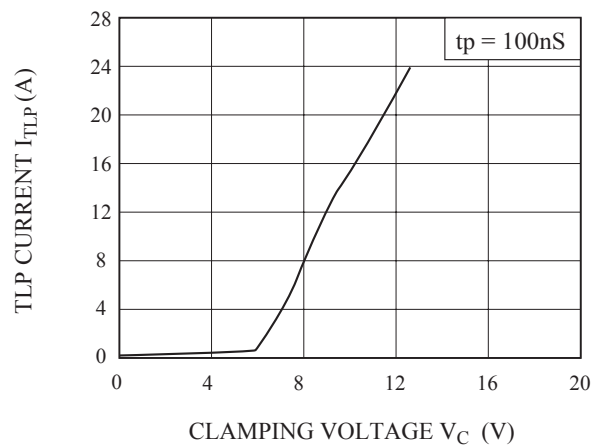

PS05CBESC

ESD Clamping
(+8 kV Contact per IEC 61000-4-2)

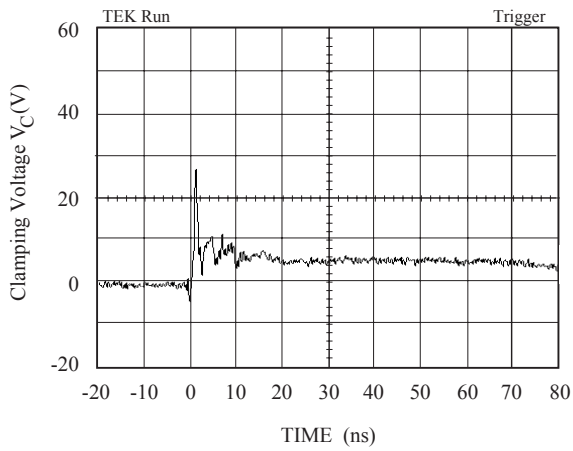

Note : Data is taken with a 10x attenuator

ESD Clamping
(-8 kV Contact per IEC 61000-4-2)

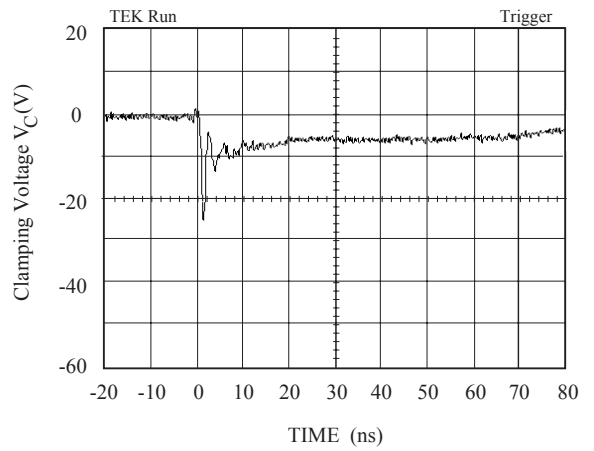

Note : Data is taken with a 10x attenuator

PULSE WAVEFORM

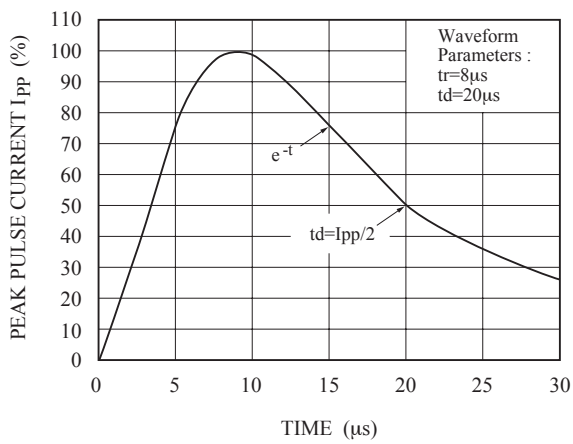

PS05CBESC

APPLICATIONS

- MDDI Port
- LCD-Display, Camera
- GPS / FM Antennas
- LVDS
- Wifi Module, Bluetooth Module

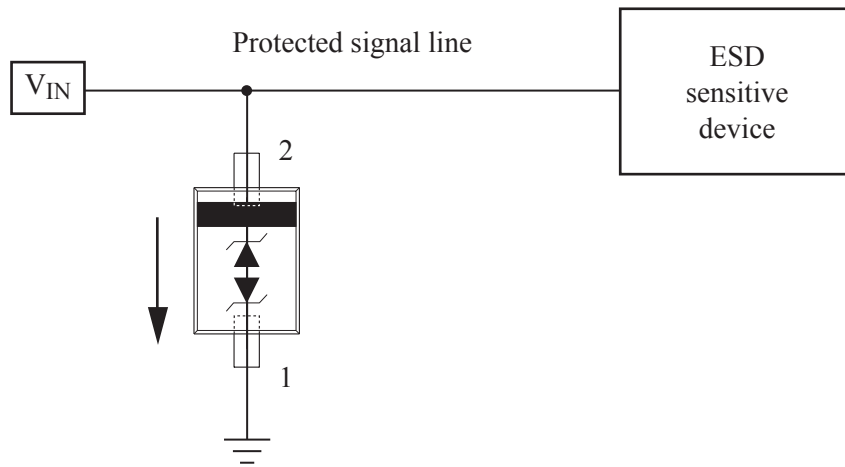

Recommended pad dimension & Marking Information

Recommended pad dimension	Marking Code