

Low Clamping Voltage.
Bi-directional ESD / Transient Protection Diodes

FEATURES

- Transient protection for data lines to
 - IEC61000-4-2(ESD) : Air mode $\pm 25\text{kV}$ / Contact mode $\pm 20\text{kV}$
 - IEC61000-4-5(Surge) : $7\text{A}(t_p=8/20\mu\text{s})$
- Total capacitance $C_T = 25\text{pF}(\text{Max})$
- Bi-directional, symmetrical working voltage up to : $V_{RWM} = \pm 12\text{V}$
- Ultra small Size $1.0 \times 0.6 \times 0.4\text{mm}$
- Non Suffix : ULP-2 Package ex) PG12DBUL2-RTL/H
- Suffix **U** : ULP-2 Package&Qualified to AEC-Q101 ex) PG12DBUL2-RTL/HU
- Suffix **R** : ULP-2(4) Package ex) PG12DBUL2-RTL/HR
- Suffix **UR** : ULP-2(4) Package&Qualified to AEC-Q101 ex) PG12DBUL2-RTL/HUR
- Suffix **P** : ULP-2(5) Package ex) PG12DBUL2-RTL/HP
- Suffix **UP** : ULP-2(5) Package&Qualified to AEC-Q101 ex) PG12DBUL2-RTL/HUP
- Suffix **UJ** : ULP-2(6) Package&Qualified to AEC-Q101 ex) PG12DBUL2-RTL/HUJ



ULP-2 (leadless-type)

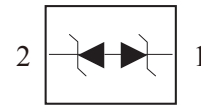

1. CATHODE 2. CATHODE

Pin configurations (Bi-directional)

PRODUCT DESCRIPTION

- Molding compound flammability rating : UL 94V-0
- Pb-Free, Halogen-Free, RoHs Compliant

Package dimensions (ULP-2)	Package dimensions (ULP-2(3))	Package dimensions (ULP-2(4))	Package dimensions (ULP-2(5))	Package dimensions (ULP-2(6))																																																																																						
<table border="1"> <thead> <tr> <th>DIM</th> <th>MILLIMETERS</th> </tr> </thead> <tbody> <tr><td>A</td><td>1.0±0.05</td></tr> <tr><td>B</td><td>0.6±0.05</td></tr> <tr><td>C</td><td>0.4±0.05</td></tr> <tr><td>C1</td><td>0.38^{+0.02}_{-0.02}</td></tr> <tr><td>D</td><td>0.54±0.03</td></tr> <tr><td>E</td><td>0.25±0.03</td></tr> <tr><td>G</td><td>0.65±0.03</td></tr> <tr><td>H</td><td>0.05</td></tr> <tr><td>I</td><td>Max 0.05</td></tr> </tbody> </table>	DIM	MILLIMETERS	A	1.0±0.05	B	0.6±0.05	C	0.4±0.05	C1	0.38 ^{+0.02} _{-0.02}	D	0.54±0.03	E	0.25±0.03	G	0.65±0.03	H	0.05	I	Max 0.05	<table border="1"> <thead> <tr> <th>DIM</th> <th>MILLIMETERS</th> </tr> </thead> <tbody> <tr><td>A</td><td>1.0±0.05</td></tr> <tr><td>B</td><td>0.6±0.05</td></tr> <tr><td>C</td><td>0.4±0.05</td></tr> <tr><td>D</td><td>0.48±0.05</td></tr> <tr><td>e</td><td>0.23±0.05</td></tr> <tr><td>e</td><td>Min 0.125</td></tr> <tr><td>G</td><td>0.65±0.03</td></tr> <tr><td>H</td><td>Typ 0.06</td></tr> </tbody> </table>	DIM	MILLIMETERS	A	1.0±0.05	B	0.6±0.05	C	0.4±0.05	D	0.48±0.05	e	0.23±0.05	e	Min 0.125	G	0.65±0.03	H	Typ 0.06	<table border="1"> <thead> <tr> <th>DIM</th> <th>MILLIMETERS</th> </tr> </thead> <tbody> <tr><td>A</td><td>1.00±0.10</td></tr> <tr><td>B</td><td>0.60±0.10</td></tr> <tr><td>C</td><td>0.40±0.05</td></tr> <tr><td>D</td><td>0.50±0.05</td></tr> <tr><td>E</td><td>0.25±0.05</td></tr> <tr><td>G</td><td>Typ 0.65</td></tr> <tr><td>H</td><td>0.05±0.05</td></tr> </tbody> </table>	DIM	MILLIMETERS	A	1.00±0.10	B	0.60±0.10	C	0.40±0.05	D	0.50±0.05	E	0.25±0.05	G	Typ 0.65	H	0.05±0.05	<table border="1"> <thead> <tr> <th>DIM</th> <th>MILLIMETERS</th> </tr> </thead> <tbody> <tr><td>A</td><td>1.00±0.05</td></tr> <tr><td>B</td><td>0.60±0.05</td></tr> <tr><td>C</td><td>0.50±0.05</td></tr> <tr><td>D</td><td>0.50±0.03</td></tr> <tr><td>E</td><td>0.25±0.03</td></tr> <tr><td>G</td><td>0.65 BSC</td></tr> <tr><td>I</td><td>Max 0.03</td></tr> </tbody> </table>	DIM	MILLIMETERS	A	1.00±0.05	B	0.60±0.05	C	0.50±0.05	D	0.50±0.03	E	0.25±0.03	G	0.65 BSC	I	Max 0.03	<table border="1"> <thead> <tr> <th>DIM</th> <th>MILLIMETER</th> </tr> </thead> <tbody> <tr><td>A</td><td>1.00±0.05</td></tr> <tr><td>B</td><td>0.60±0.05</td></tr> <tr><td>C</td><td>0.60±0.05</td></tr> <tr><td>D</td><td>0.50±0.02-0.04</td></tr> <tr><td>E</td><td>0.25±0.025</td></tr> <tr><td>G</td><td>0.65BSC</td></tr> <tr><td>I</td><td>Max 0.03</td></tr> </tbody> </table>	DIM	MILLIMETER	A	1.00±0.05	B	0.60±0.05	C	0.60±0.05	D	0.50±0.02-0.04	E	0.25±0.025	G	0.65BSC	I	Max 0.03
DIM	MILLIMETERS																																																																																									
A	1.0±0.05																																																																																									
B	0.6±0.05																																																																																									
C	0.4±0.05																																																																																									
C1	0.38 ^{+0.02} _{-0.02}																																																																																									
D	0.54±0.03																																																																																									
E	0.25±0.03																																																																																									
G	0.65±0.03																																																																																									
H	0.05																																																																																									
I	Max 0.05																																																																																									
DIM	MILLIMETERS																																																																																									
A	1.0±0.05																																																																																									
B	0.6±0.05																																																																																									
C	0.4±0.05																																																																																									
D	0.48±0.05																																																																																									
e	0.23±0.05																																																																																									
e	Min 0.125																																																																																									
G	0.65±0.03																																																																																									
H	Typ 0.06																																																																																									
DIM	MILLIMETERS																																																																																									
A	1.00±0.10																																																																																									
B	0.60±0.10																																																																																									
C	0.40±0.05																																																																																									
D	0.50±0.05																																																																																									
E	0.25±0.05																																																																																									
G	Typ 0.65																																																																																									
H	0.05±0.05																																																																																									
DIM	MILLIMETERS																																																																																									
A	1.00±0.05																																																																																									
B	0.60±0.05																																																																																									
C	0.50±0.05																																																																																									
D	0.50±0.03																																																																																									
E	0.25±0.03																																																																																									
G	0.65 BSC																																																																																									
I	Max 0.03																																																																																									
DIM	MILLIMETER																																																																																									
A	1.00±0.05																																																																																									
B	0.60±0.05																																																																																									
C	0.60±0.05																																																																																									
D	0.50±0.02-0.04																																																																																									
E	0.25±0.025																																																																																									
G	0.65BSC																																																																																									
I	Max 0.03																																																																																									

ORDERING INFORMATION

Part Number	Qty per Reel	Reel Size	Marking code
PG12DBUL2-RTL	10,000	7 inch	HH

PG12DBUL2

MAXIMUM RATING (Ta=25°C)

CHARACTERISTIC	SYMBOL	RATING	UNIT
Peak Pulse Power (tp=8/20 μs)	P _{PK}	160	W
Peak Pulse Current (tp=8/20 μs)	I _{PP}	7	A
Junction Temperature	T _J	150	°C
Storage Temperature	T _{STG}	-55 ~ 150	°C

DEFINITIONS OF ELECTRICAL CHARACTERISTIC SYMBOL

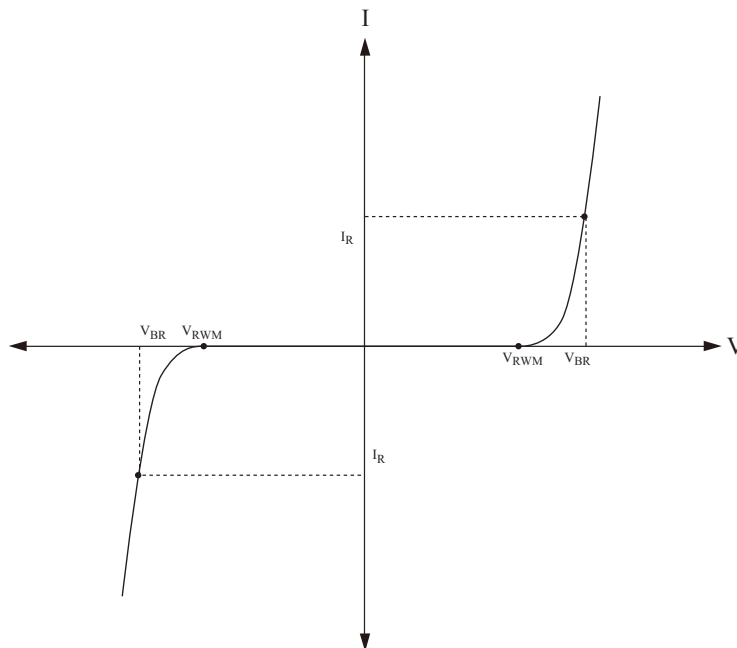

ELECTRICAL CHARACTERISTICS (Ta=25°C)

CHARACTERISTIC	SYMBOL	TEST CONDITION	MIN.	TYP.	MAX.	UNIT	
Reverse Stand-Off Voltage	V_{RWM}	-	-	-	12	V	
Reverse Breakdown Voltage	V_{BR}	$I_R=5mA$	14.8	-	16.3	V	
Reverse Leakage Current	I_R	$V_{RWM}=12V$	-	-	100	nA	
Total Capacitance	C_T	$V_R=0V, f=1MHz$	-	-	25	pF	
Clamping Voltage	V_C	$I_{pp}=1A, tp=8/20 \mu s$ (IEC61000-4-5)	-	17	20	V	
		$I_{pp}=7A, tp=8/20 \mu s$ (IEC61000-4-5)	-	20	23		
Electrostatic Discharge	V_{ESD}	IEC61000-4-2	Air	±25	-	-	kV
			Contact	±20			

PG12DBUL2

NON-REPETITIVE PEAK PULSE POWER VS. PULSE TIME

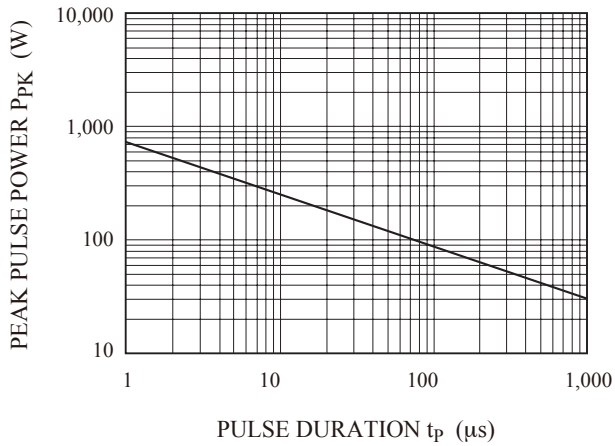

POWER DERATION CURVE

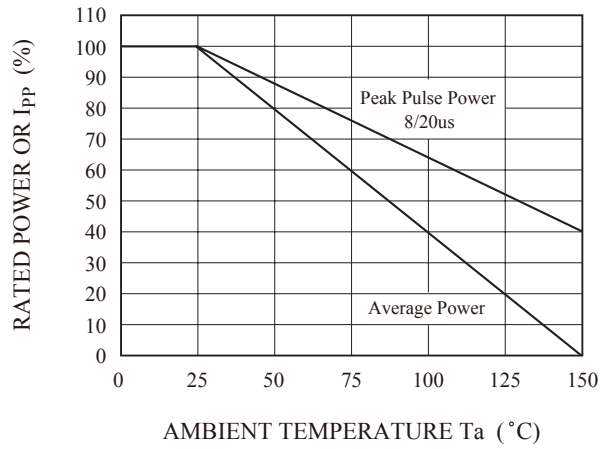

$I_R - V_R$

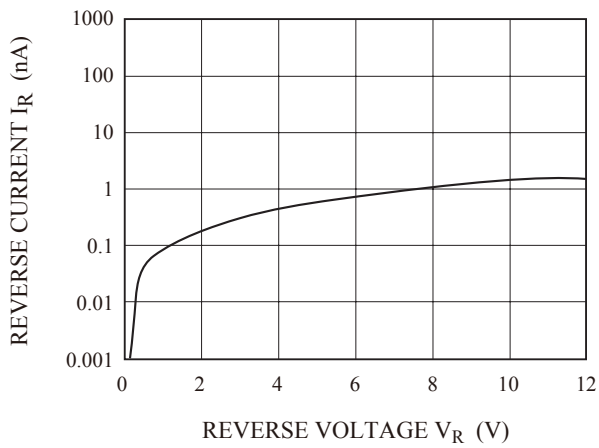

$C_T - V_R$

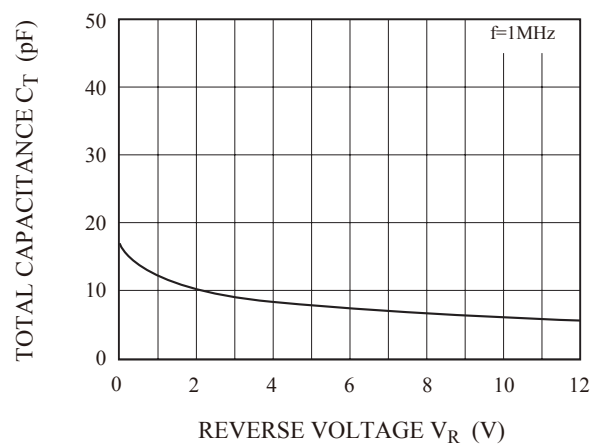

$I_{pp} - V_C$

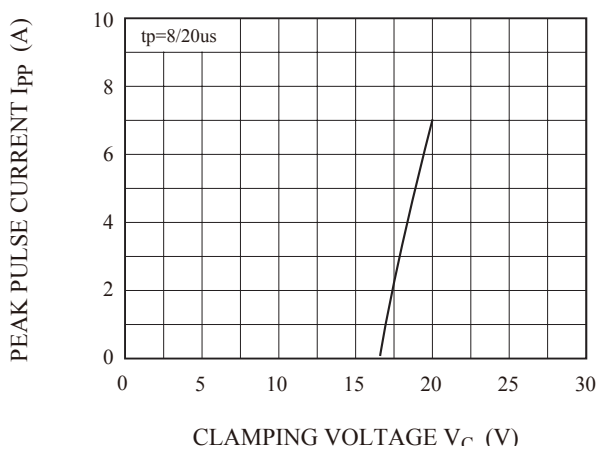

PULSE WAVEFORM

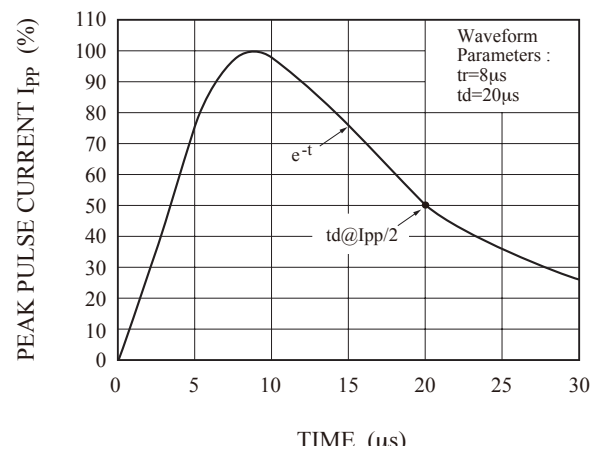

PG12DBUL2

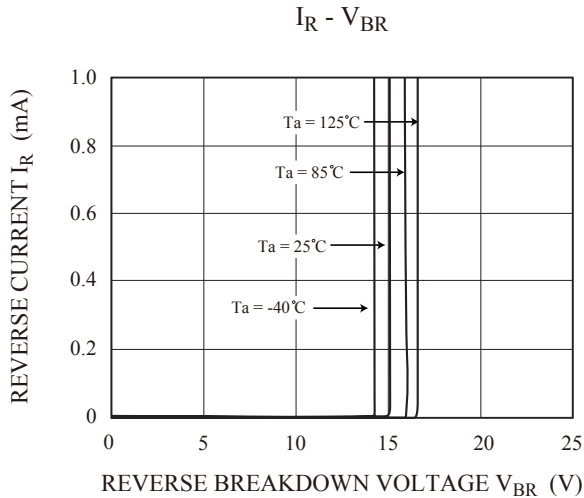

PG12DBUL2

APPLICATIONS

- Portable electronics
- Cellular handsets and accessories
- Speaker
- Wireless Charger

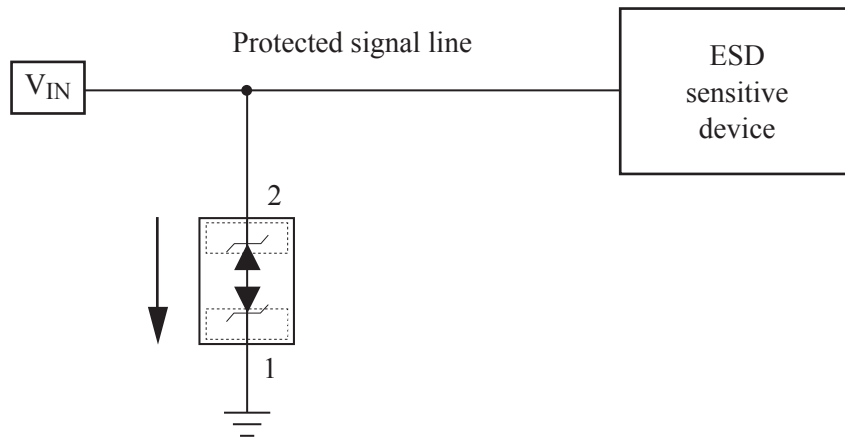

Recommended pad dimension & Marking Information

Recommended pad dimension	Marking Code